



Full wwPDB EM Validation Report ⓘ

Dec 11, 2022 – 08:18 am GMT

PDB ID : 6RXX
EMDB ID : EMD-10054
Title : Cryo-EM structure of the 90S pre-ribosome (Kre33-Noc4) from *Chaetomium thermophilum*, state C, Poly-Ala
Authors : Cheng, J.; Kellner, N.; Griesel, S.; Berninghausen, O.; Beckmann, R.; Hurt, E.
Deposited on : 2019-06-10
Resolution : 7.10 Å(reported)

This is a Full wwPDB EM Validation Report for a publicly released PDB entry.

We welcome your comments at validation@mail.wwpdb.org

A user guide is available at

<https://www.wwpdb.org/validation/2017/EMValidationReportHelp>

with specific help available everywhere you see the ⓘ symbol.

The types of validation reports are described at

<http://www.wwpdb.org/validation/2017/FAQs#types>.

The following versions of software and data (see [references ⓘ](#)) were used in the production of this report:

EMDB validation analysis : 0.0.1.dev43
MolProbity : 4.02b-467
Percentile statistics : 20191225.v01 (using entries in the PDB archive December 25th 2019)
MapQ : 1.9.9
Ideal geometry (proteins) : Engh & Huber (2001)
Ideal geometry (DNA, RNA) : Parkinson et al. (1996)
Validation Pipeline (wwPDB-VP) : 2.31.3

1 Overall quality at a glance

The following experimental techniques were used to determine the structure:
ELECTRON MICROSCOPY

The reported resolution of this entry is 7.10 Å.

Percentile scores (ranging between 0-100) for global validation metrics of the entry are shown in the following graphic. The table shows the number of entries on which the scores are based.

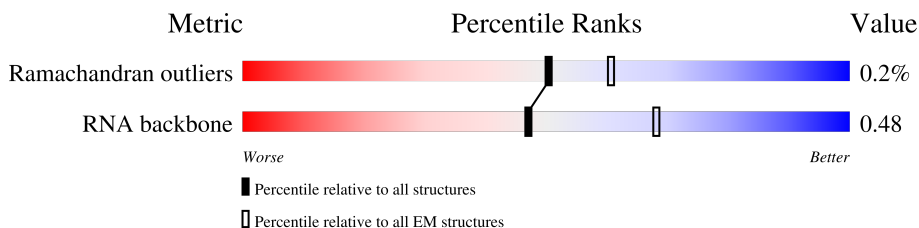

Metric	Whole archive (#Entries)	EM structures (#Entries)
Ramachandran outliers	154571	4023
RNA backbone	4643	859

The table below summarises the geometric issues observed across the polymeric chains and their fit to the map. The red, orange, yellow and green segments of the bar indicate the fraction of residues that contain outliers for ≥ 3 , 2, 1 and 0 types of geometric quality criteria respectively. A grey segment represents the fraction of residues that are not modelled. The numeric value for each fraction is indicated below the corresponding segment, with a dot representing fractions $\leq 5\%$. The upper red bar (where present) indicates the fraction of residues that have poor fit to the EM map (all-atom inclusion $< 40\%$). The numeric value is given above the bar.

Mol	Chain	Length	Quality of chain
1	UA	904	
2	UC	648	
3	UF	414	
4	UG	558	
5	UK	270	
6	UL	962	
7	UM	912	
8	UN	938	
9	UR	618	

Continued on next page...

Continued from previous page...

Mol	Chain	Length	Quality of chain
10	UU	1049	7% 86% 14%
11	UX	193	26% 98% .
12	CJ	183	15% 98% .
13	CK	297	17% 100%
14	CL	785	6% 29% 71%
15	CM	446	5% 100%
16	CN	252	28% 90% 10%
16	CO	252	33% 84% 15%
17	CP	322	31% 62% 38%
18	CQ	259	54% 67% 32%
19	Ca	255	16% 88% 12%
20	Cc	212	6% 90% 9%
21	Ce	203	19% 78% 22%
22	Cg	190	13% 84% 16%
23	Ch	151	14% 93% 6% ..
24	Ci	150	17% 77% 23%
25	Cj	143	14% 88% 12%
26	Cm	130	11% 97% .
27	Cn	145	. 66% 34%
28	Cp	68	7% 90% 10%
29	Cq	82	21% 95% ...
30	CU	311	48% 57% 43%
31	C1	1859	9% 41% 21% 34%
32	UV	1171	37% 90% 9%
33	CV	322	20% 45% 54%

Continued on next page...

Continued from previous page...

Mol	Chain	Length	Quality of chain
34	Cl	156	
35	CH	411	
36	CI	1163	
37	CR	1073	
37	CS	1073	
38	Cb	264	
39	Cd	239	
40	Cf	202	
41	Ck	161	
42	Co	136	
43	CW	668	
44	UT	2612	
45	CZ	609	
46	UB	907	
47	UD	884	
48	UJ	1802	
49	UO	557	
50	UQ	960	
51	CX	480	
52	UE	410	
52	UI	410	
53	UP	364	
54	UH	930	
55	US	549	
56	CA	313	

Continued on next page...

Continued from previous page...

Mol	Chain	Length	Quality of chain
56	CB	313	
57	CC	523	
58	CD	582	
59	CE	127	
59	CF	127	
60	CG	630	
61	CT	203	
62	C2	232	
63	Cr	153	

2 Entry composition [i](#)

There are 64 unique types of molecules in this entry. The entry contains 146382 atoms, of which 0 are hydrogens and 0 are deuteriums.

In the tables below, the AltConf column contains the number of residues with at least one atom in alternate conformation and the Trace column contains the number of residues modelled with at most 2 atoms.

- Molecule 1 is a protein called Periodic tryptophan protein 2-like protein.

Mol	Chain	Residues	Atoms				AltConf	Trace
			Total	C	N	O		
1	UA	839	4136	2458	839	839	0	0

- Molecule 2 is a protein called Utp3.

Mol	Chain	Residues	Atoms				AltConf	Trace
			Total	C	N	O		
2	UC	74	361	213	74	74	0	0

- Molecule 3 is a protein called Utp6.

Mol	Chain	Residues	Atoms				AltConf	Trace
			Total	C	N	O		
3	UF	331	1644	982	331	331	0	0

- Molecule 4 is a protein called Utp7.

Mol	Chain	Residues	Atoms				AltConf	Trace
			Total	C	N	O		
4	UG	479	2361	1403	479	479	0	0

- Molecule 5 is a protein called U3 small nucleolar RNA-associated protein 11.

Mol	Chain	Residues	Atoms				AltConf	Trace
			Total	C	N	O		
5	UK	217	1070	636	217	217	0	0

- Molecule 6 is a protein called Utp12.

Mol	Chain	Residues	Atoms				AltConf	Trace
			Total	C	N	O		
6	UL	785	3877	2307	785	785	0	0

- Molecule 7 is a protein called Utp13.

Mol	Chain	Residues	Atoms				AltConf	Trace
			Total	C	N	O		
7	UM	729	3602	2144	729	729	0	0

- Molecule 8 is a protein called Utp14.

Mol	Chain	Residues	Atoms				AltConf	Trace
			Total	C	N	O		
8	UN	177	880	526	177	177	0	0

- Molecule 9 is a protein called Utp18.

Mol	Chain	Residues	Atoms				AltConf	Trace
			Total	C	N	O		
9	UR	447	2198	1304	447	447	0	0

- Molecule 10 is a protein called Putative U3 snoRNP protein.

Mol	Chain	Residues	Atoms				AltConf	Trace
			Total	C	N	O		
10	UU	902	4424	2620	902	902	0	0

- Molecule 11 is a protein called Utp24.

Mol	Chain	Residues	Atoms				AltConf	Trace
			Total	C	N	O		
11	UX	190	942	562	190	190	0	0

- Molecule 12 is a protein called Imp3.

Mol	Chain	Residues	Atoms				AltConf	Trace
			Total	C	N	O		
12	CJ	179	890	532	179	179	0	0

- Molecule 13 is a protein called Putative U3 small nucleolar ribonucleoprotein.

Mol	Chain	Residues	Atoms				AltConf	Trace
			Total	C	N	O		
13	CK	297	1472	878	297	297	0	0

- Molecule 14 is a protein called Putative U3 small nucleolar ribonucleoprotein protein.

Mol	Chain	Residues	Atoms				AltConf	Trace
14	CL	231	Total	C	N	O	0	0
			1142	680	231	231		

- Molecule 15 is a protein called Sof1.

Mol	Chain	Residues	Atoms				AltConf	Trace
15	CM	445	Total	C	N	O	0	0
			2201	1311	445	445		

- Molecule 16 is a protein called Emg1.

Mol	Chain	Residues	Atoms				AltConf	Trace
16	CN	226	Total	C	N	O	0	0
			1122	670	226	226		
16	CO	215	Total	C	N	O	0	0
			1067	637	215	215		

- Molecule 17 is a protein called KRR1 small subunit processome component.

Mol	Chain	Residues	Atoms				AltConf	Trace
17	CP	201	Total	C	N	O	0	0
			995	593	201	201		

- Molecule 18 is a protein called Pre-rRNA-processing protein PNO1.

Mol	Chain	Residues	Atoms				AltConf	Trace
18	CQ	175	Total	C	N	O	0	0
			864	514	175	175		

- Molecule 19 is a protein called 40S ribosomal protein S1.

Mol	Chain	Residues	Atoms				AltConf	Trace
19	Ca	225	Total	C	N	O	0	0
			1115	665	225	225		

- Molecule 20 is a protein called 40S ribosomal protein s5-like protein.

Mol	Chain	Residues	Atoms				AltConf	Trace
20	Cc	192	Total	C	N	O	0	0
			953	569	192	192		

- Molecule 21 is a protein called 40S ribosomal protein S7.

Mol	Chain	Residues	Atoms				AltConf	Trace
21	Ce	159	Total	C	N	O	0	0
			786	468	159	159		

- Molecule 22 is a protein called 40S ribosomal protein s9-like protein.

Mol	Chain	Residues	Atoms				AltConf	Trace
22	Cg	159	Total	C	N	O	0	0
			785	467	159	159		

- Molecule 23 is a protein called 40S ribosomal protein S13-like protein.

Mol	Chain	Residues	Atoms				AltConf	Trace
23	Ch	150	Total	C	N	O	0	0
			741	441	150	150		

- Molecule 24 is a protein called 40S ribosomal protein S14-like protein.

Mol	Chain	Residues	Atoms				AltConf	Trace
24	Ci	115	Total	C	N	O	0	0
			563	333	115	115		

- Molecule 25 is a protein called 40S ribosomal protein S16-like protein.

Mol	Chain	Residues	Atoms				AltConf	Trace
25	Cj	126	Total	C	N	O	0	0
			622	370	126	126		

- Molecule 26 is a protein called 40S ribosomal protein S22-like protein.

Mol	Chain	Residues	Atoms				AltConf	Trace
26	Cm	126	Total	C	N	O	0	0
			620	368	126	126		

- Molecule 27 is a protein called 40S ribosomal protein s23-like protein.

Mol	Chain	Residues	Atoms				AltConf	Trace
27	Cn	96	Total	C	N	O	0	0
			469	277	96	96		

- Molecule 28 is a protein called 40S ribosomal protein S28-like protein.

Mol	Chain	Residues	Atoms				AltConf	Trace
			Total	C	N	O		
28	Cp	61	300	178	61	61	0	0

- Molecule 29 is a protein called Ribosomal protein s27-like protein.

Mol	Chain	Residues	Atoms				AltConf	Trace
			Total	C	N	O		
29	Cq	81	400	238	81	81	0	0

- Molecule 30 is a protein called Faf1.

Mol	Chain	Residues	Atoms				AltConf	Trace
			Total	C	N	O		
30	CU	176	871	519	176	176	0	0

- Molecule 31 is a RNA chain called 35S ribosomal RNA.

Mol	Chain	Residues	Atoms					AltConf	Trace
			Total	C	N	O	P		
31	C1	1221	26044	11631	4650	8542	1221	0	0

- Molecule 32 is a protein called U3 small nucleolar RNA-associated protein 22.

Mol	Chain	Residues	Atoms				AltConf	Trace
			Total	C	N	O		
32	UV	1061	5244	3122	1061	1061	0	0

- Molecule 33 is a protein called Rrp7.

Mol	Chain	Residues	Atoms				AltConf	Trace
			Total	C	N	O		
33	CV	148	732	436	148	148	0	0

- Molecule 34 is a protein called Putative ribosomal protein.

Mol	Chain	Residues	Atoms				AltConf	Trace
			Total	C	N	O		
34	Cl	80	395	235	80	80	0	0

- Molecule 35 is a protein called RNA 3'-terminal phosphate cyclase-like protein.

Mol	Chain	Residues	Atoms				AltConf	Trace
			Total	C	N	O		
35	CH	389	1902	1124	389	389	0	0

- Molecule 36 is a protein called Bms1.

Mol	Chain	Residues	Atoms				AltConf	Trace
			Total	C	N	O		
36	CI	822	4061	2417	822	822	0	0

- Molecule 37 is a protein called Kre33.

Mol	Chain	Residues	Atoms				AltConf	Trace
			Total	C	N	O		
37	CR	760	3755	2235	760	760	0	0
37	CS	760	3755	2235	760	760	0	0

- Molecule 38 is a protein called 40S ribosomal protein S4.

Mol	Chain	Residues	Atoms				AltConf	Trace
			Total	C	N	O		
38	Cb	232	1140	676	232	232	0	0

- Molecule 39 is a protein called 40S ribosomal protein S6.

Mol	Chain	Residues	Atoms				AltConf	Trace
			Total	C	N	O		
39	Cd	226	1112	660	226	226	0	0

- Molecule 40 is a protein called 40S ribosomal protein S8.

Mol	Chain	Residues	Atoms				AltConf	Trace
			Total	C	N	O		
40	Cf	174	852	504	174	174	0	0

- Molecule 41 is a protein called 40S ribosomal protein S11-like protein.

Mol	Chain	Residues	Atoms				AltConf	Trace
			Total	C	N	O		
41	Ck	140	691	411	140	140	0	0

- Molecule 42 is a protein called 40S ribosomal protein S24.

Mol	Chain	Residues	Atoms				AltConf	Trace
42	Co	92	Total	C	N	O	0	0
			453	269	92	92		

- Molecule 43 is a protein called Ribosome biogenesis protein ENP2.

Mol	Chain	Residues	Atoms				AltConf	Trace
43	CW	382	Total	C	N	O	0	0
			1880	1116	382	382		

- Molecule 44 is a protein called Utp20.

Mol	Chain	Residues	Atoms				AltConf	Trace
44	UT	2018	Total	C	N	O	0	0
			10012	5976	2018	2018		

- Molecule 45 is a protein called Bfr2.

Mol	Chain	Residues	Atoms				AltConf	Trace
45	CZ	42	Total	C	N	O	0	0
			207	123	42	42		

- Molecule 46 is a protein called Utp2.

Mol	Chain	Residues	Atoms				AltConf	Trace
46	UB	508	Total	C	N	O	0	0
			2521	1505	508	508		

- Molecule 47 is a protein called Utp4.

Mol	Chain	Residues	Atoms				AltConf	Trace
47	UD	772	Total	C	N	O	0	0
			3799	2255	772	772		

- Molecule 48 is a protein called UTP10.

Mol	Chain	Residues	Atoms				AltConf	Trace
48	UJ	1090	Total	C	N	O	0	0
			5405	3225	1090	1090		

- Molecule 49 is a protein called Utp15.

Mol	Chain	Residues	Atoms				AltConf	Trace
49	UO	504	Total	C	N	O	0	0
			2486	1478	504	504		

- Molecule 50 is a protein called Utp17.

Mol	Chain	Residues	Atoms				AltConf	Trace
50	UQ	789	Total	C	N	O	0	0
			3899	2321	789	789		

- Molecule 51 is a protein called Enp1.

Mol	Chain	Residues	Atoms				AltConf	Trace
51	CX	267	Total	C	N	O	0	0
			1325	791	267	267		

- Molecule 52 is a protein called Utp5.

Mol	Chain	Residues	Atoms				AltConf	Trace
52	UI	125	Total	C	N	O	0	0
			616	366	125	125		
52	UE	125	Total	C	N	O	0	0
			616	366	125	125		

- Molecule 53 is a protein called Utp16.

Mol	Chain	Residues	Atoms				AltConf	Trace
53	UP	54	Total	C	N	O	0	0
			265	157	54	54		

- Molecule 54 is a protein called Utp8.

Mol	Chain	Residues	Atoms				AltConf	Trace
54	UH	359	Total	C	N	O	0	0
			1771	1053	359	359		

- Molecule 55 is a protein called Noc4.

Mol	Chain	Residues	Atoms				AltConf	Trace
55	US	451	Total	C	N	O	0	0
			2245	1343	451	451		

- Molecule 56 is a protein called Nop1.

Mol	Chain	Residues	Atoms				AltConf	Trace
56	CA	242	Total	C	N	O	0	0
			1189	705	242	242		
56	CB	222	Total	C	N	O	0	0
			1092	648	222	222		

- Molecule 57 is a protein called Putative nucleolar protein.

Mol	Chain	Residues	Atoms				AltConf	Trace
57	CC	387	Total	C	N	O	0	0
			1911	1137	387	387		

- Molecule 58 is a protein called Nop58.

Mol	Chain	Residues	Atoms				AltConf	Trace
58	CD	420	Total	C	N	O	0	0
			2073	1233	420	420		

- Molecule 59 is a protein called Snu13.

Mol	Chain	Residues	Atoms				AltConf	Trace
59	CE	121	Total	C	N	O	0	0
			601	359	121	121		
59	CF	120	Total	C	N	O	0	0
			596	356	120	120		

- Molecule 60 is a protein called Rrp9.

Mol	Chain	Residues	Atoms				AltConf	Trace
60	CG	416	Total	C	N	O	0	0
			2049	1217	416	416		

- Molecule 61 is a protein called Fcf2.

Mol	Chain	Residues	Atoms				AltConf	Trace
61	CT	131	Total	C	N	O	0	0
			647	385	131	131		

- Molecule 62 is a RNA chain called U3 snoRNA.

Mol	Chain	Residues	Atoms					AltConf	Trace
62	C2	229	Total	C	N	O	P	0	0
			4869	2172	851	1617	229		

- Molecule 63 is a protein called 40S ribosomal protein S19-like protein.

Mol	Chain	Residues	Atoms				AltConf	Trace
			Total	C	N	O		
63	Cr	142	697	413	142	142	0	0

- Molecule 64 is ZINC ION (three-letter code: ZN) (formula: Zn).

Mol	Chain	Residues	Atoms		AltConf
			Total	Zn	
64	UX	1	1	1	0
64	Cq	1	1	1	0

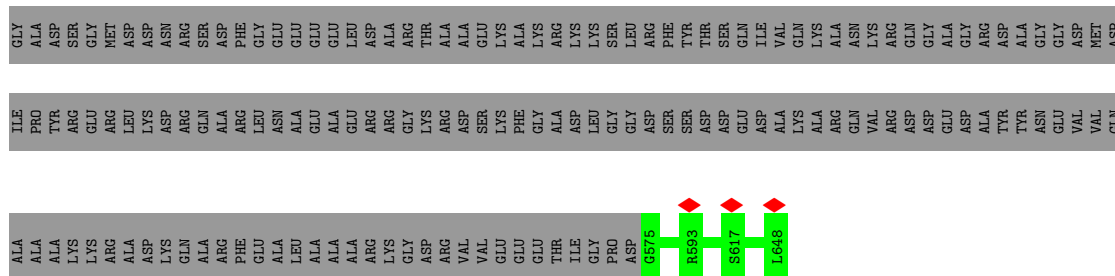

Molecule 3: Utp6

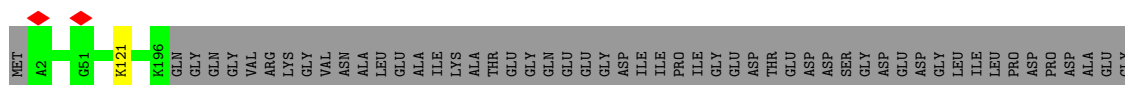
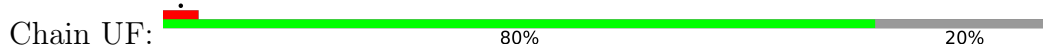

Molecule 4: Utp7

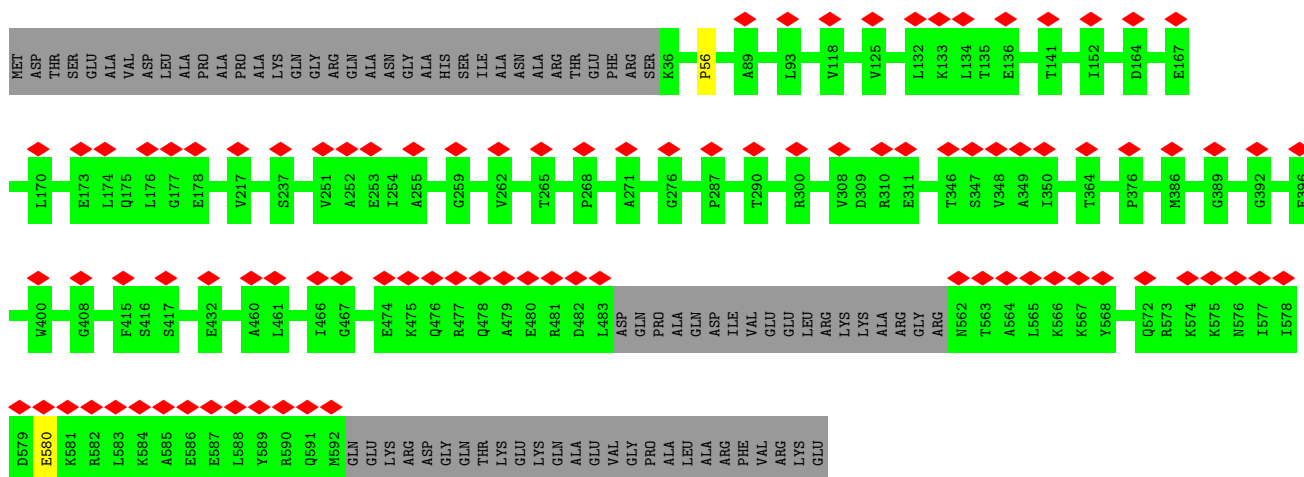
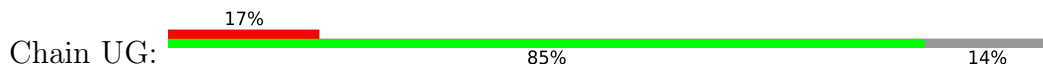

Molecule 5: U3 small nucleolar RNA-associated protein 11

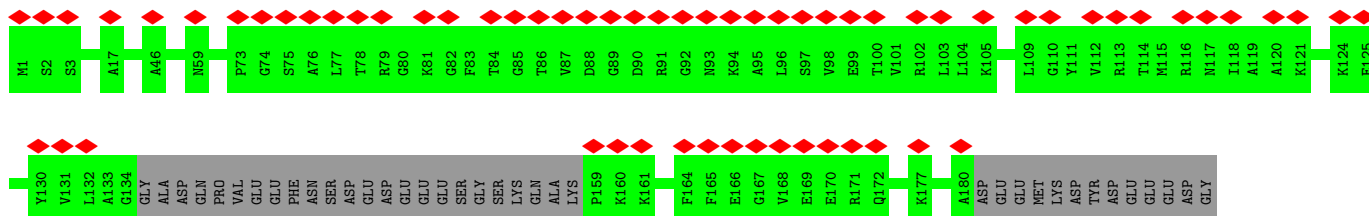
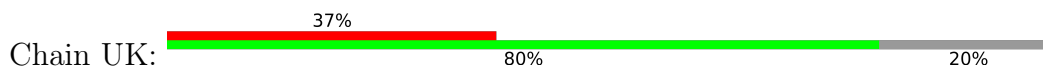

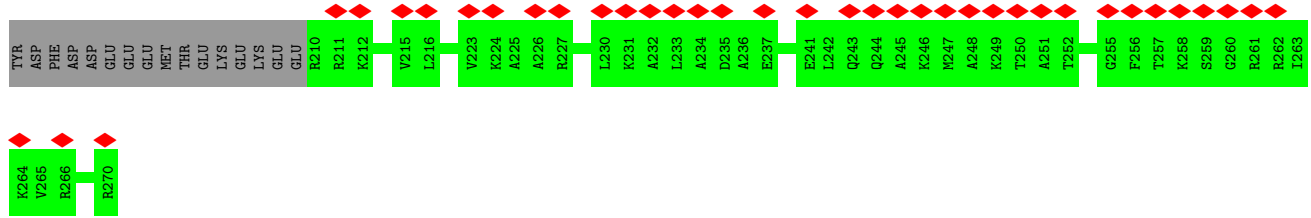

• Molecule 6: Utp12

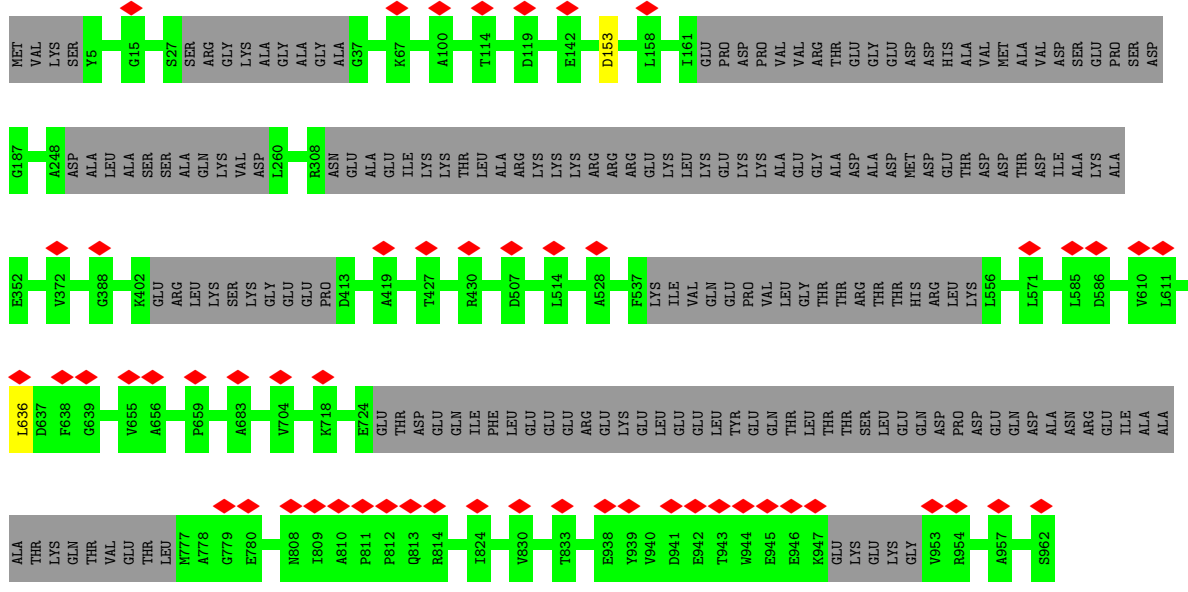
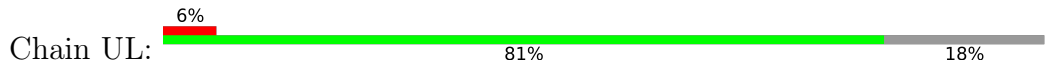

• Molecule 7: Utp13

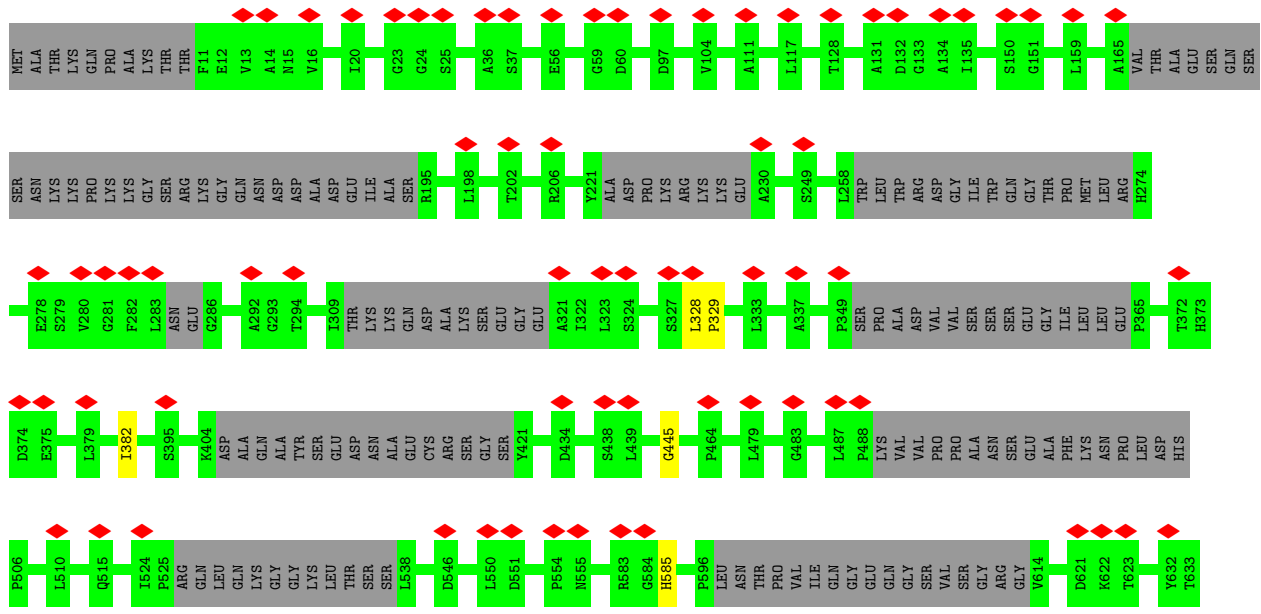
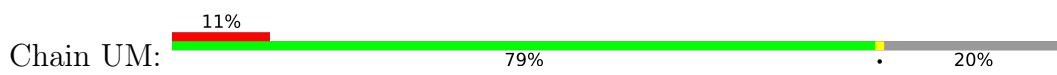

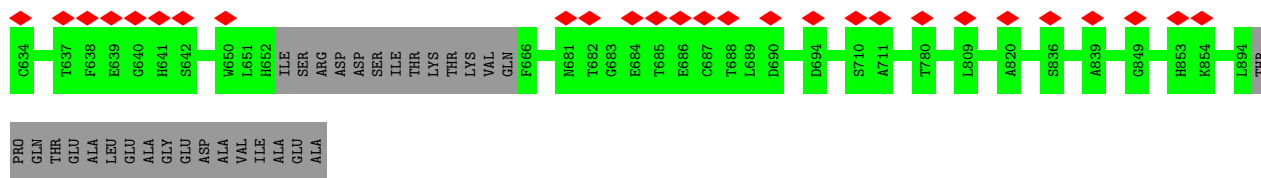

● Molecule 8: Utp14

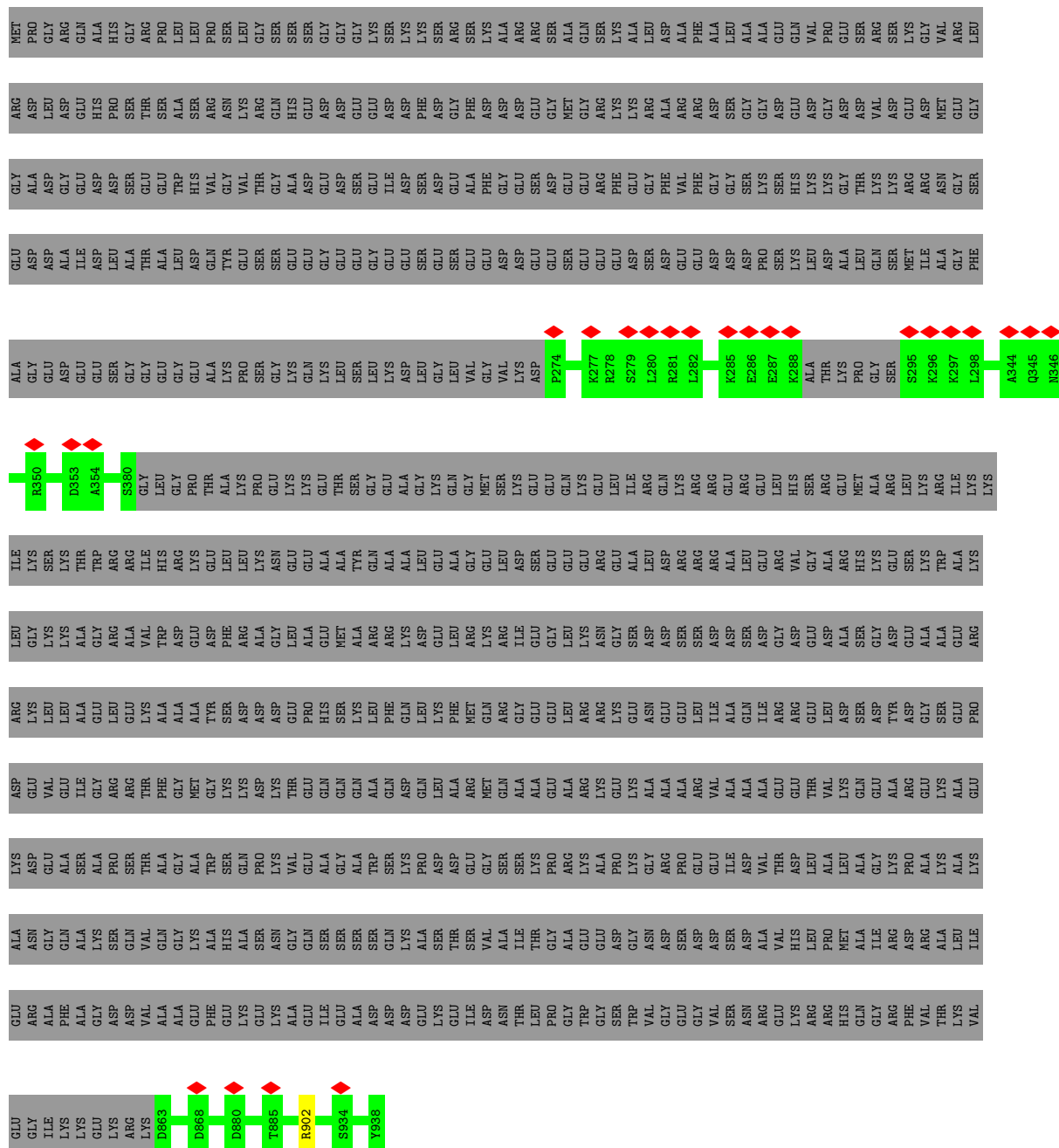

● Molecule 9: Utp18

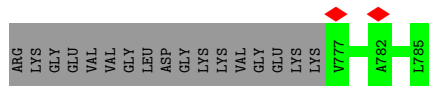
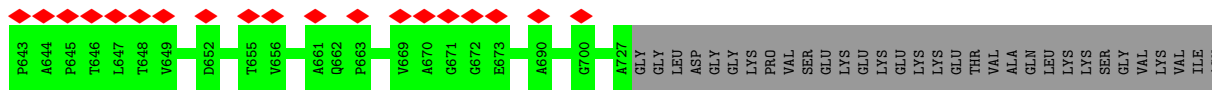

• Molecule 15: Sof1

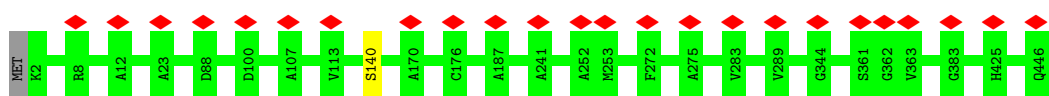

• Molecule 16: Emg1

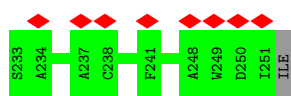
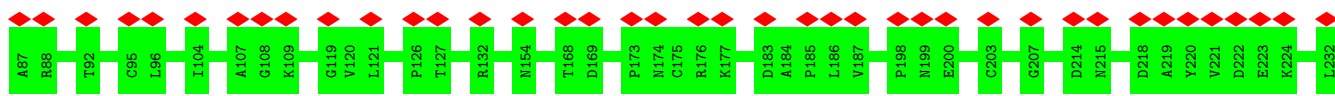
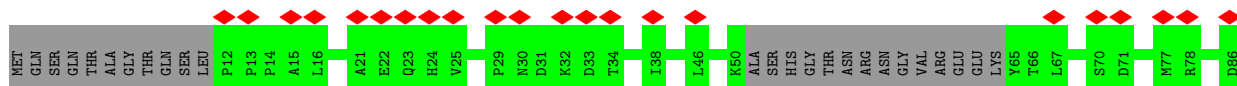
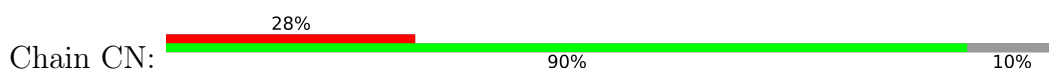

• Molecule 16: Emg1

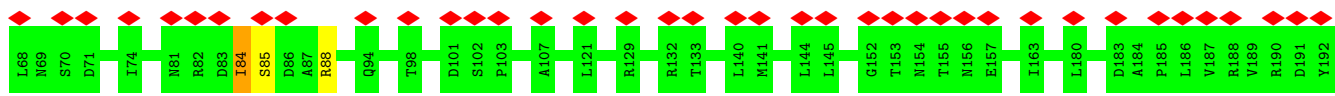
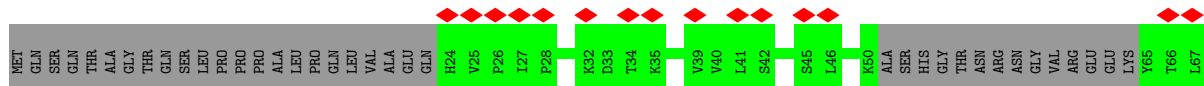
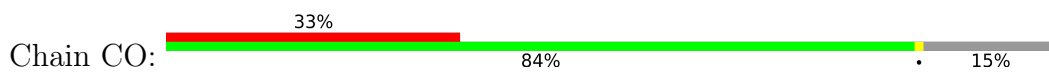

• Molecule 17: KRR1 small subunit processome component



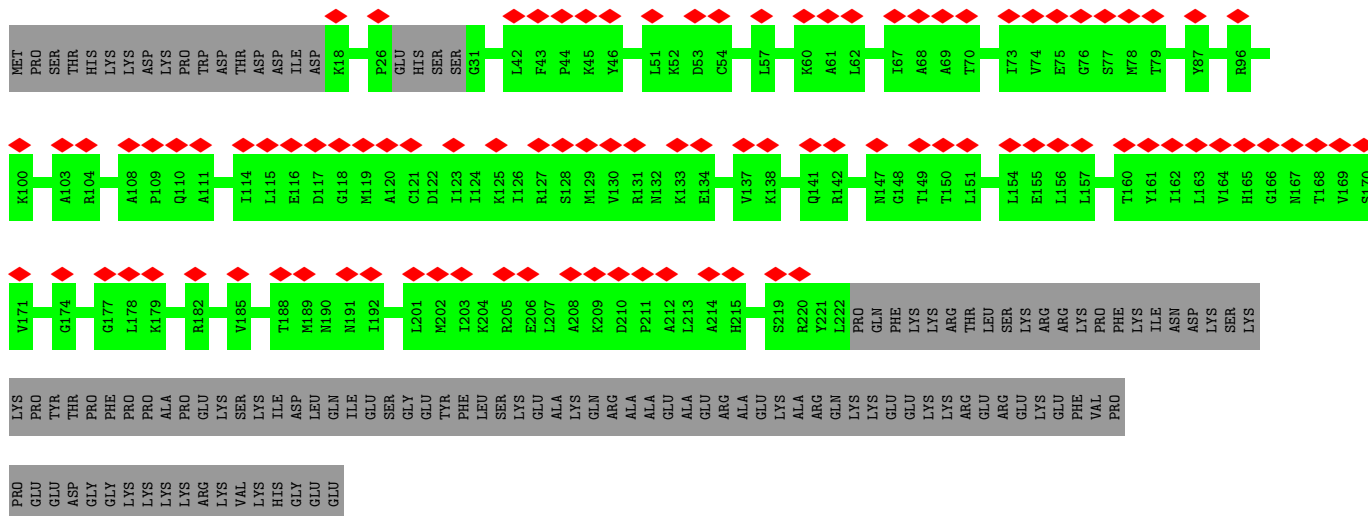

• Molecule 18: Pre-rRNA-processing protein PNO1

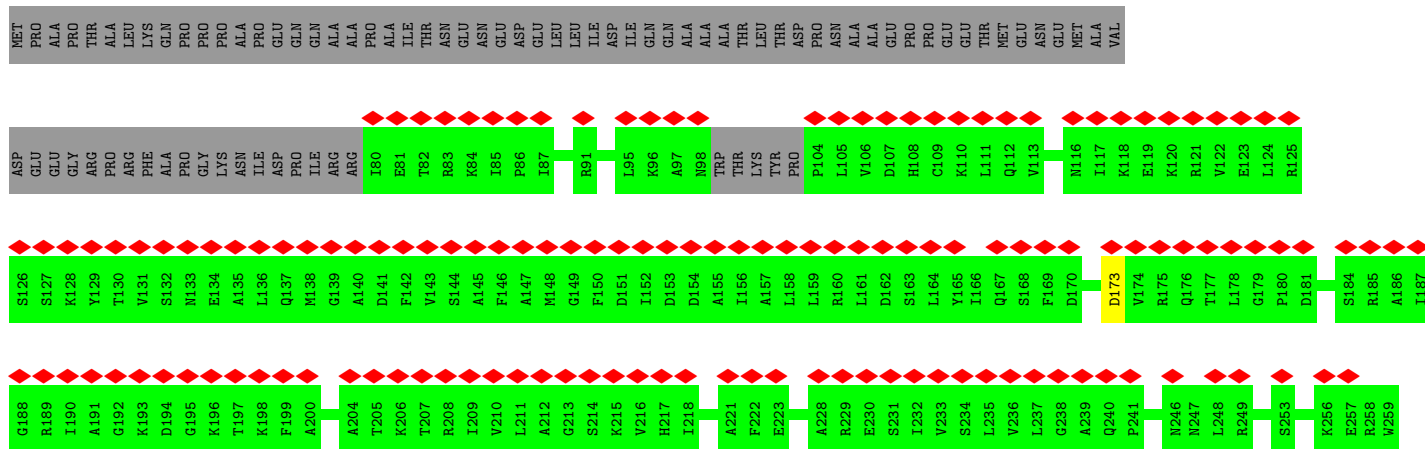

• Molecule 19: 40S ribosomal protein S1

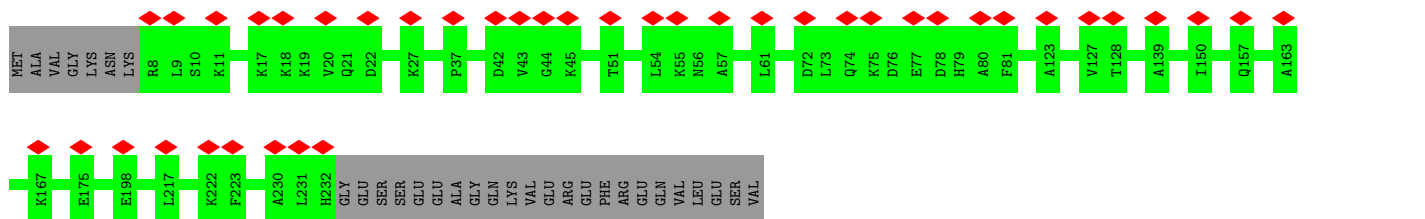
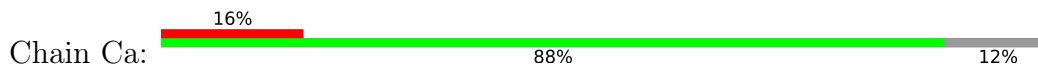

• Molecule 20: 40S ribosomal protein s5-like protein



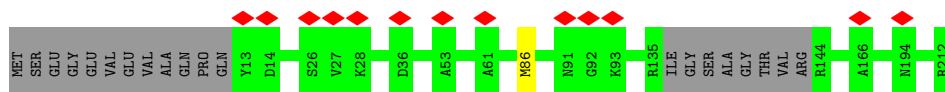

- Molecule 21: 40S ribosomal protein S7

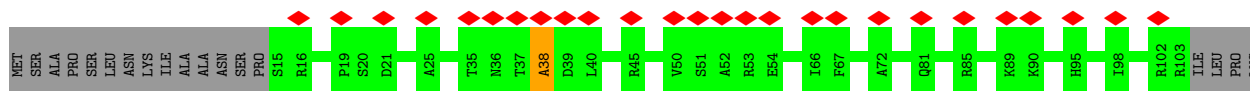
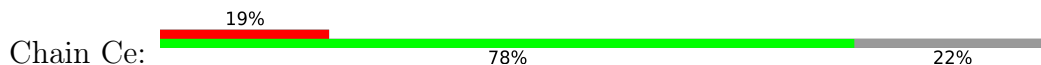

- Molecule 22: 40S ribosomal protein s9-like protein

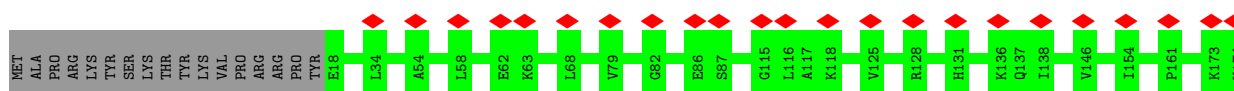
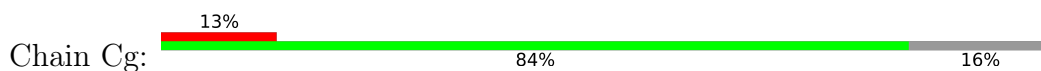

- Molecule 23: 40S ribosomal protein S13-like protein

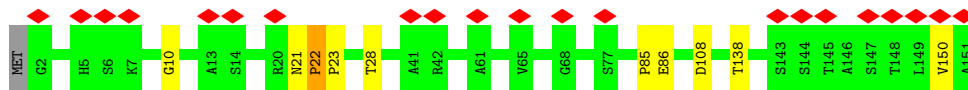

- Molecule 24: 40S ribosomal protein S14-like protein

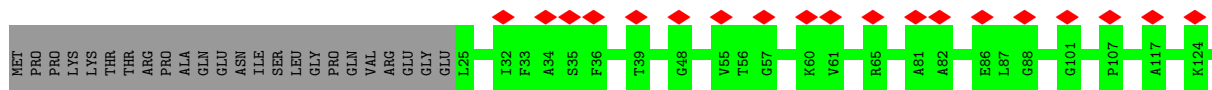
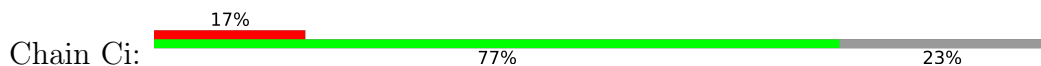

- Molecule 25: 40S ribosomal protein S16-like protein

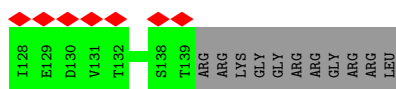
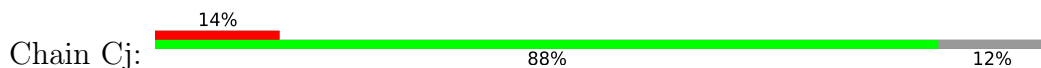

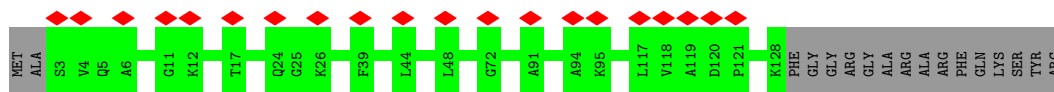

• Molecule 26: 40S ribosomal protein S22-like protein

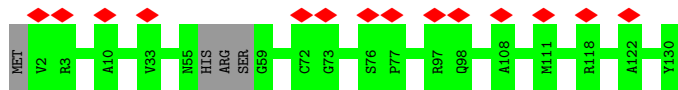

• Molecule 27: 40S ribosomal protein s23-like protein

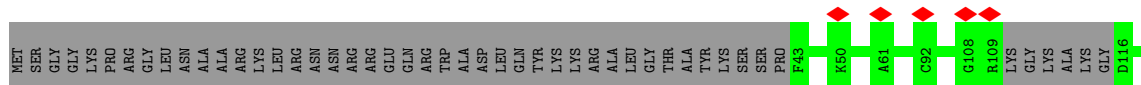

• Molecule 28: 40S ribosomal protein S28-like protein

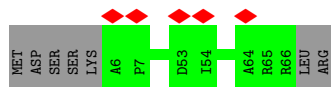
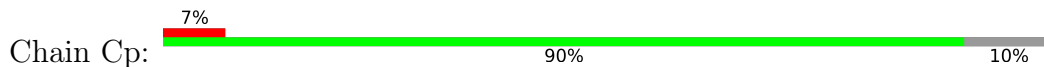

• Molecule 29: Ribosomal protein s27-like protein

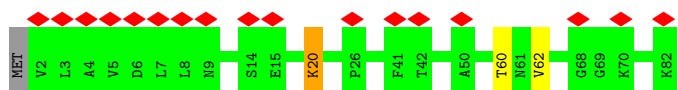

• Molecule 30: Faf1

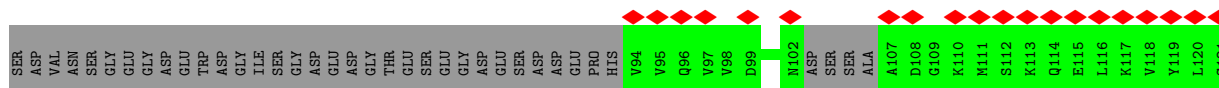
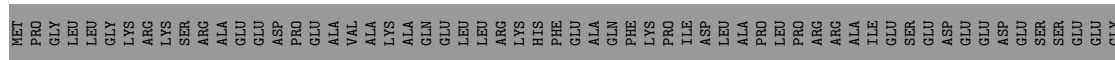

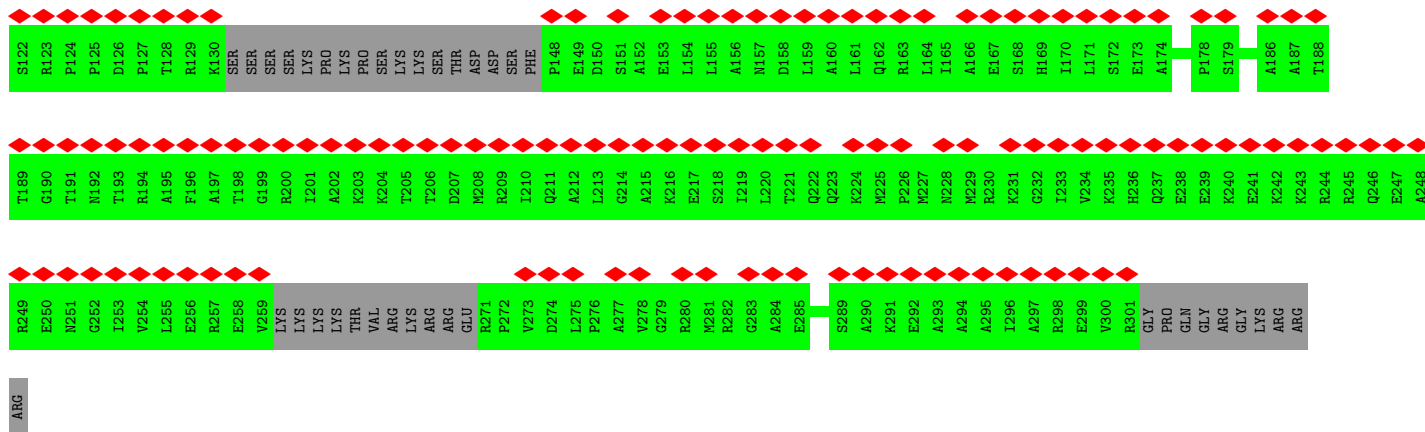

• Molecule 31: 35S ribosomal RNA

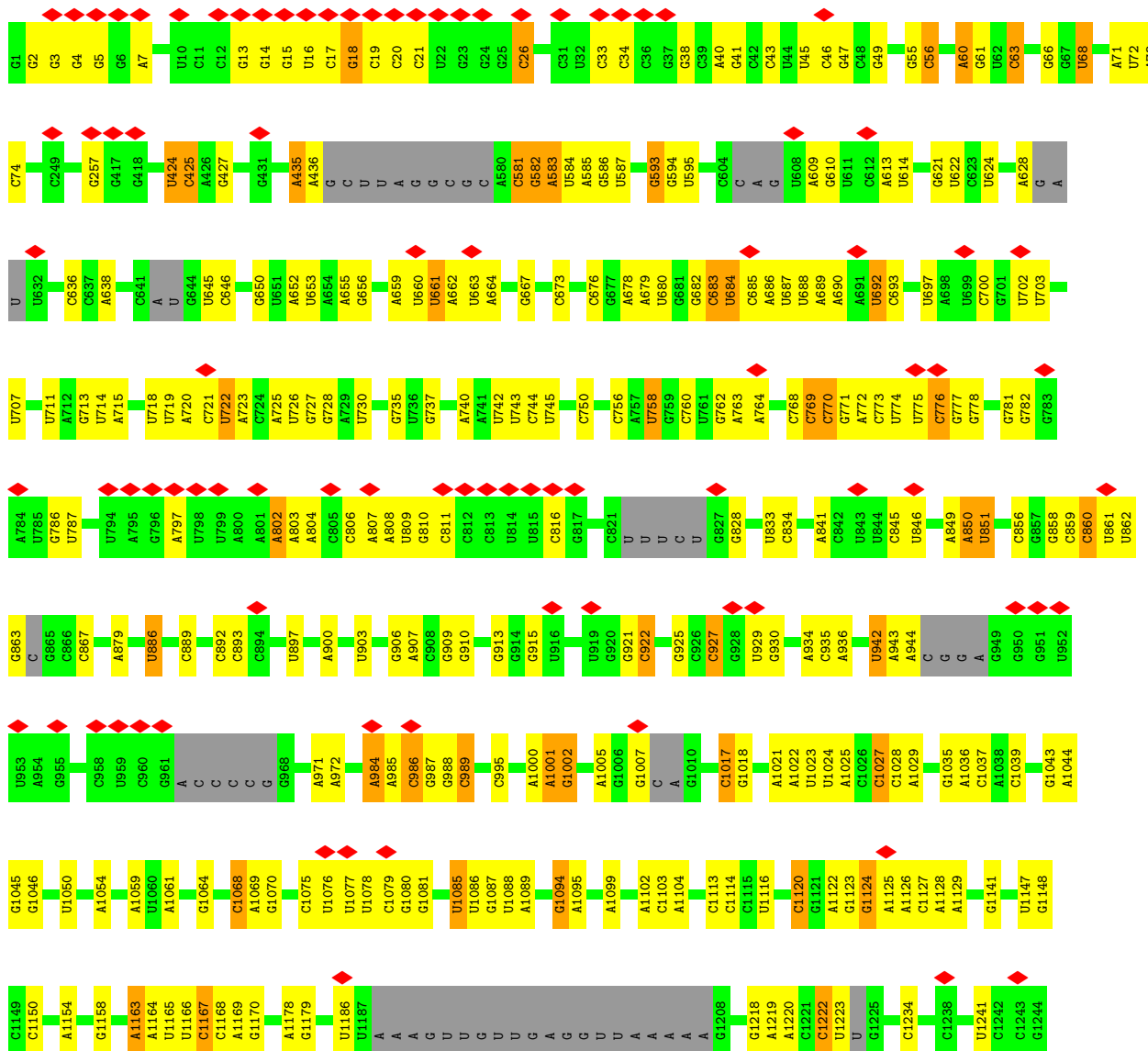

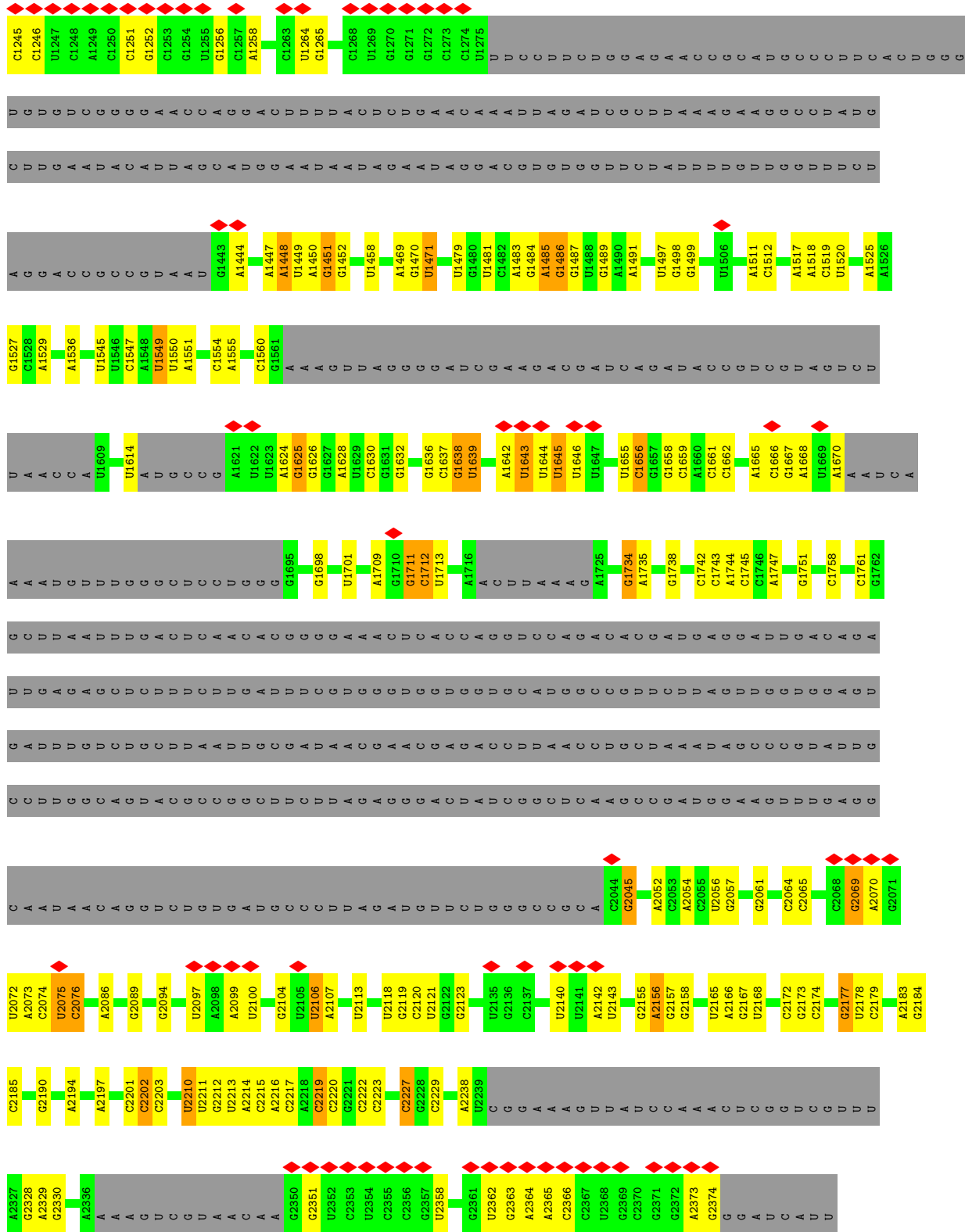

● Molecule 32: U3 small nucleolar RNA-associated protein 22

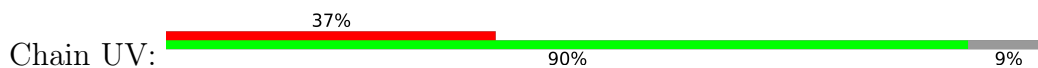

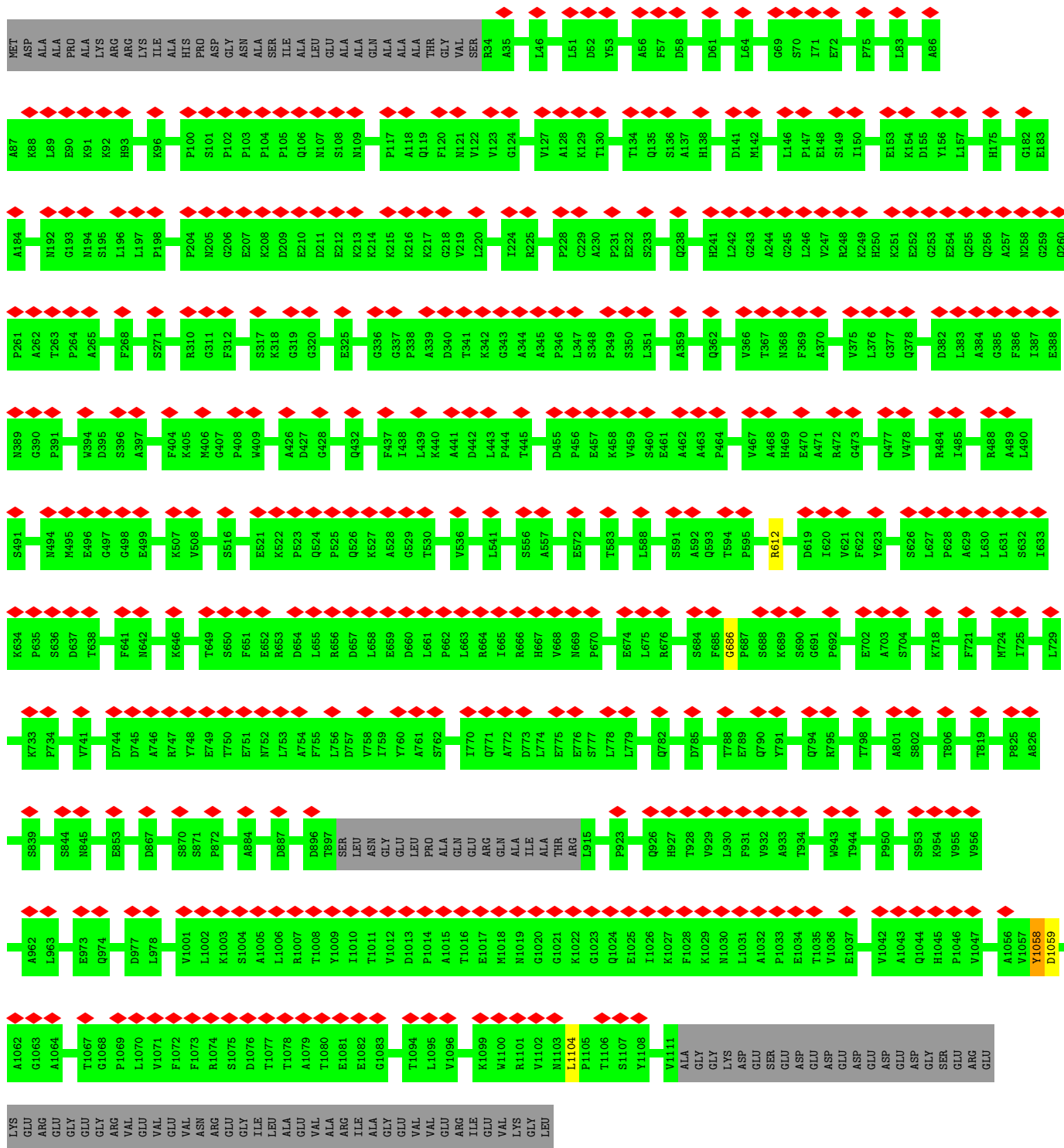

• Molecule 33: Rrp7

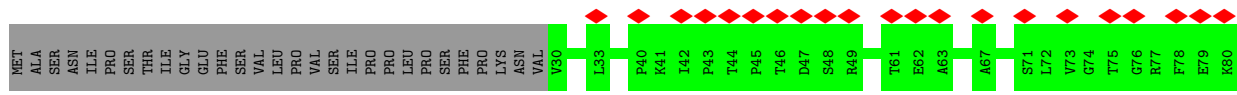

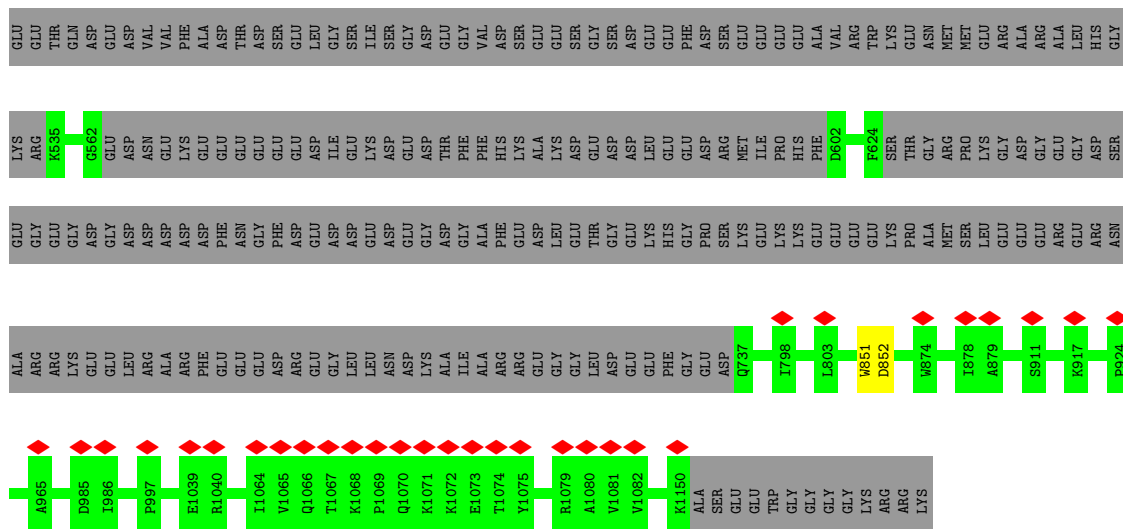

• Molecule 37: Kre33

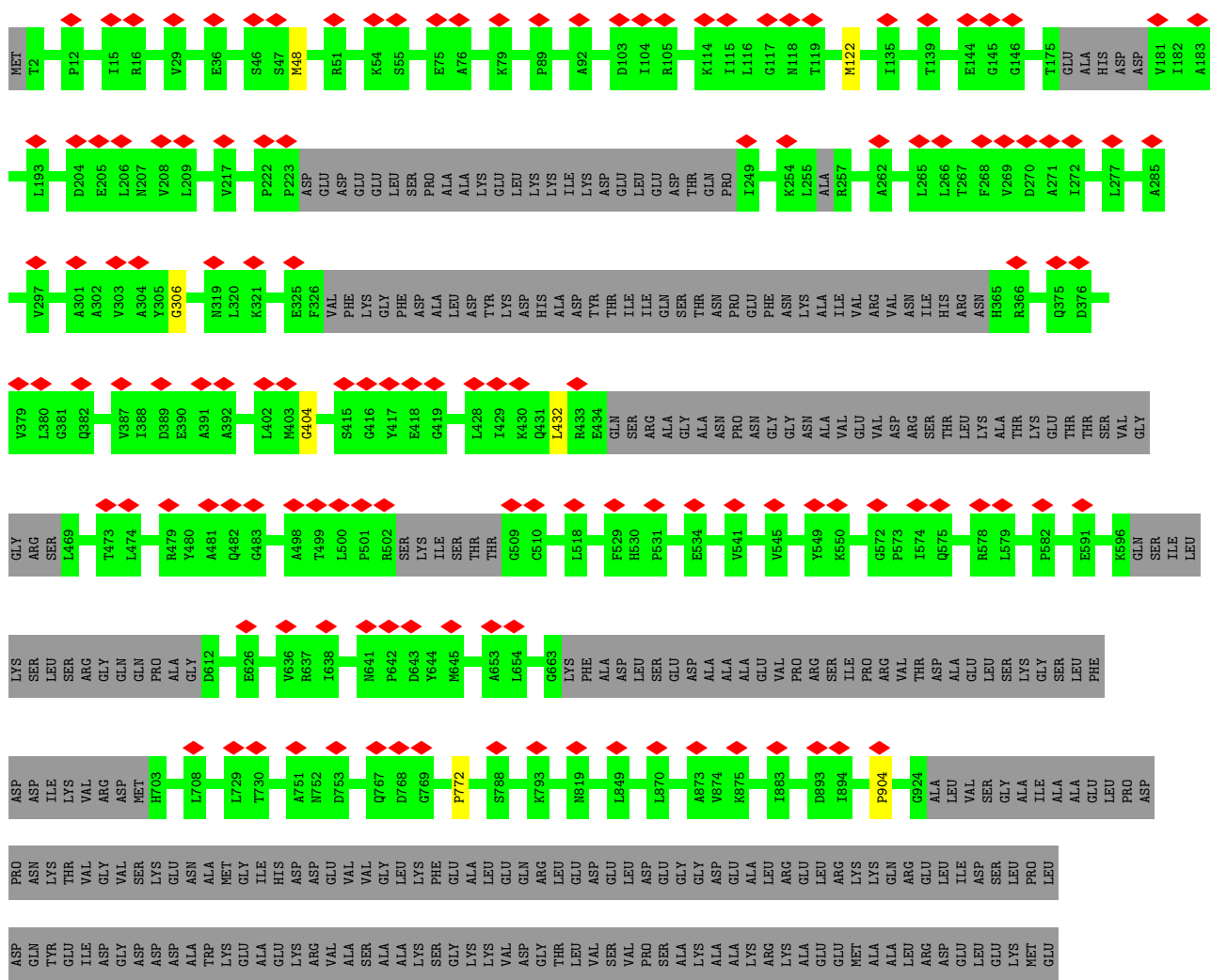
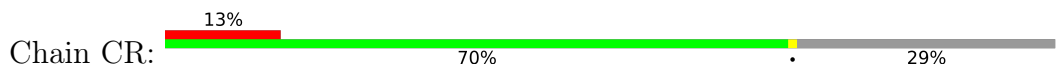

LYS
GLY
LYS
GLU
LYS
GLU
ARG
GLY
GLY
SER
LYS
LYS
ALA
ALA
LYS
GLU
LYS
ARG
ARG

• Molecule 37: Kre33

Chain CS: 28% 70% 29%

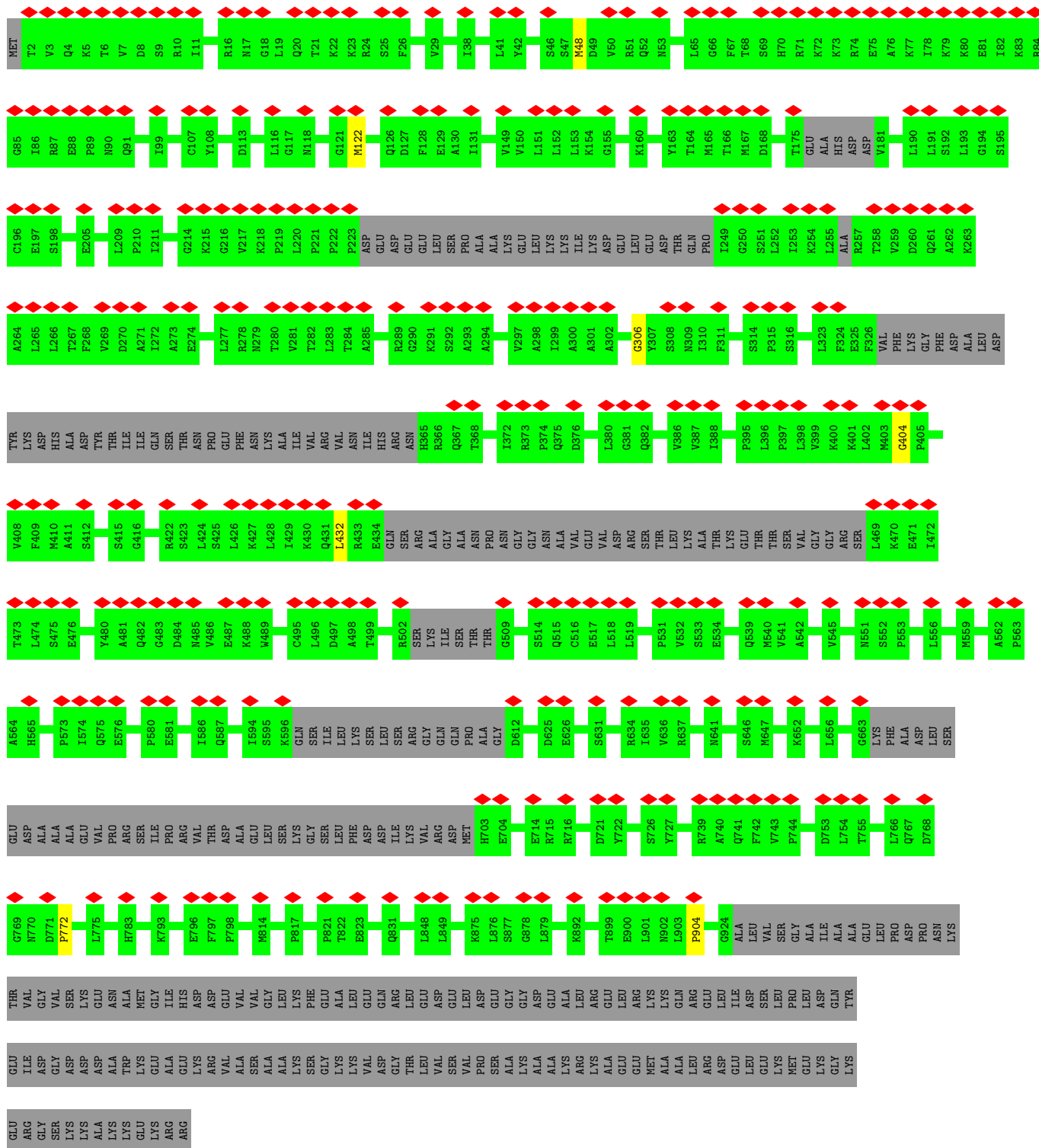

- Molecule 38: 40S ribosomal protein S4

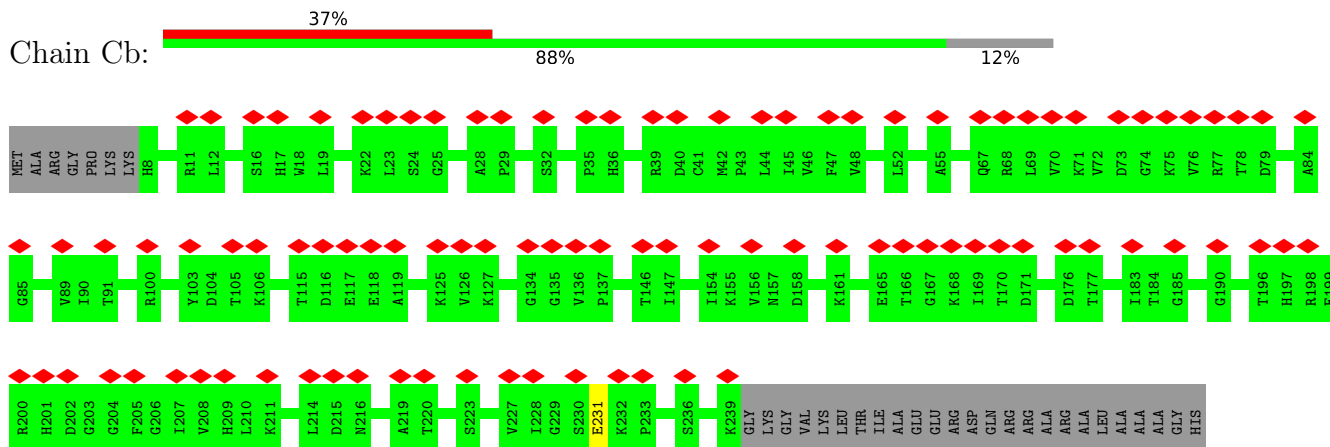

- Molecule 39: 40S ribosomal protein S6

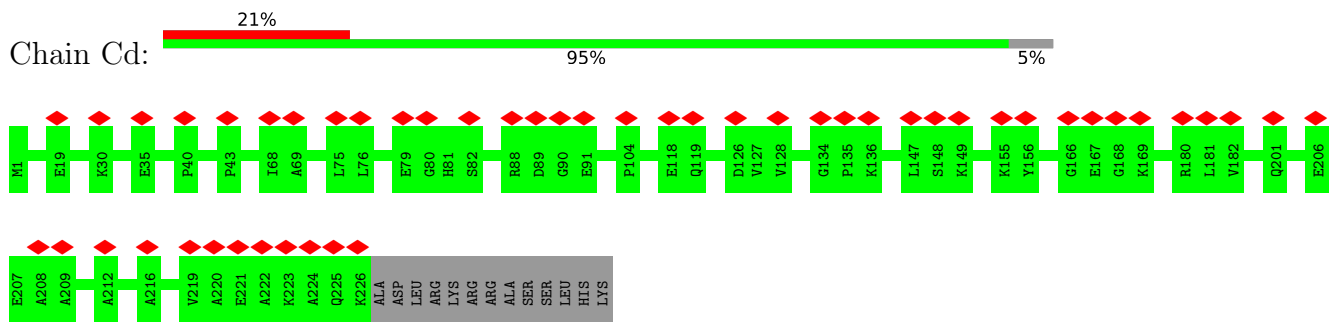

- Molecule 40: 40S ribosomal protein S8

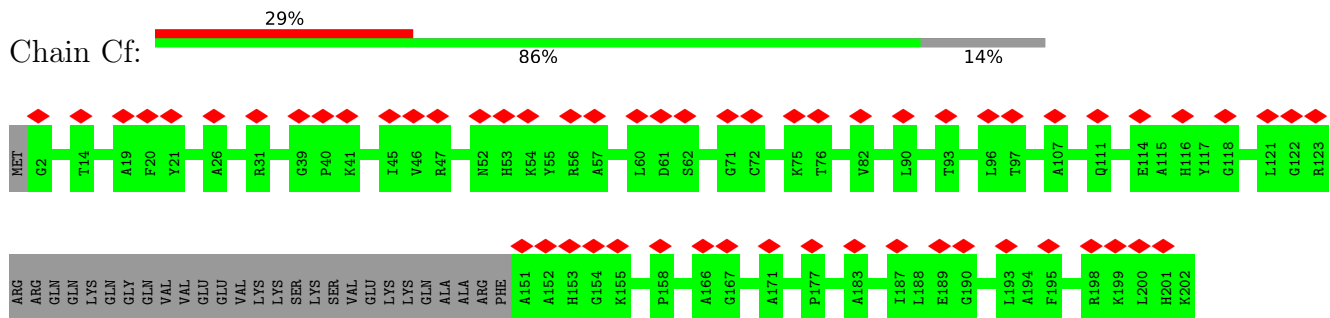

- Molecule 41: 40S ribosomal protein S11-like protein

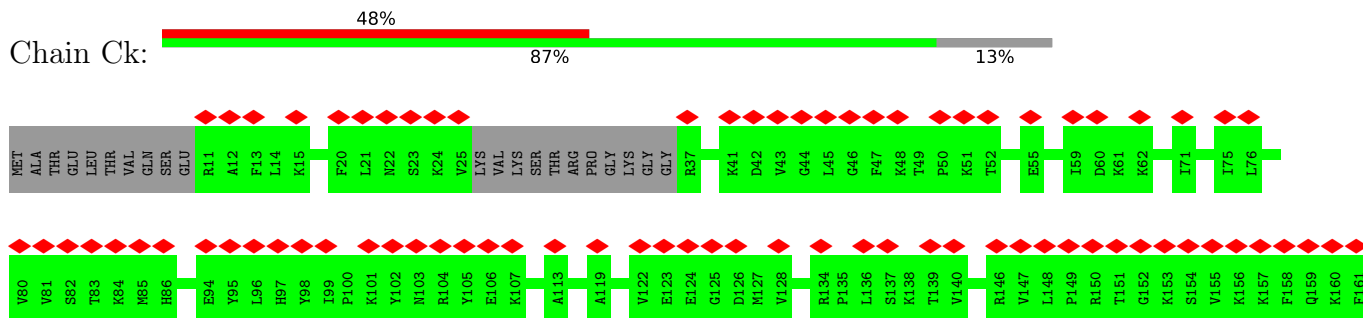

- Molecule 42: 40S ribosomal protein S24

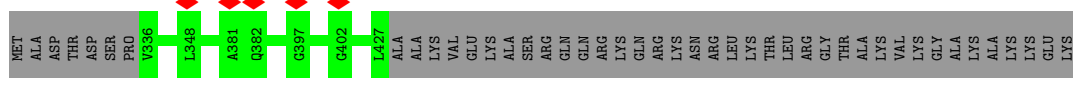

• Molecule 43: Ribosome biogenesis protein ENP2

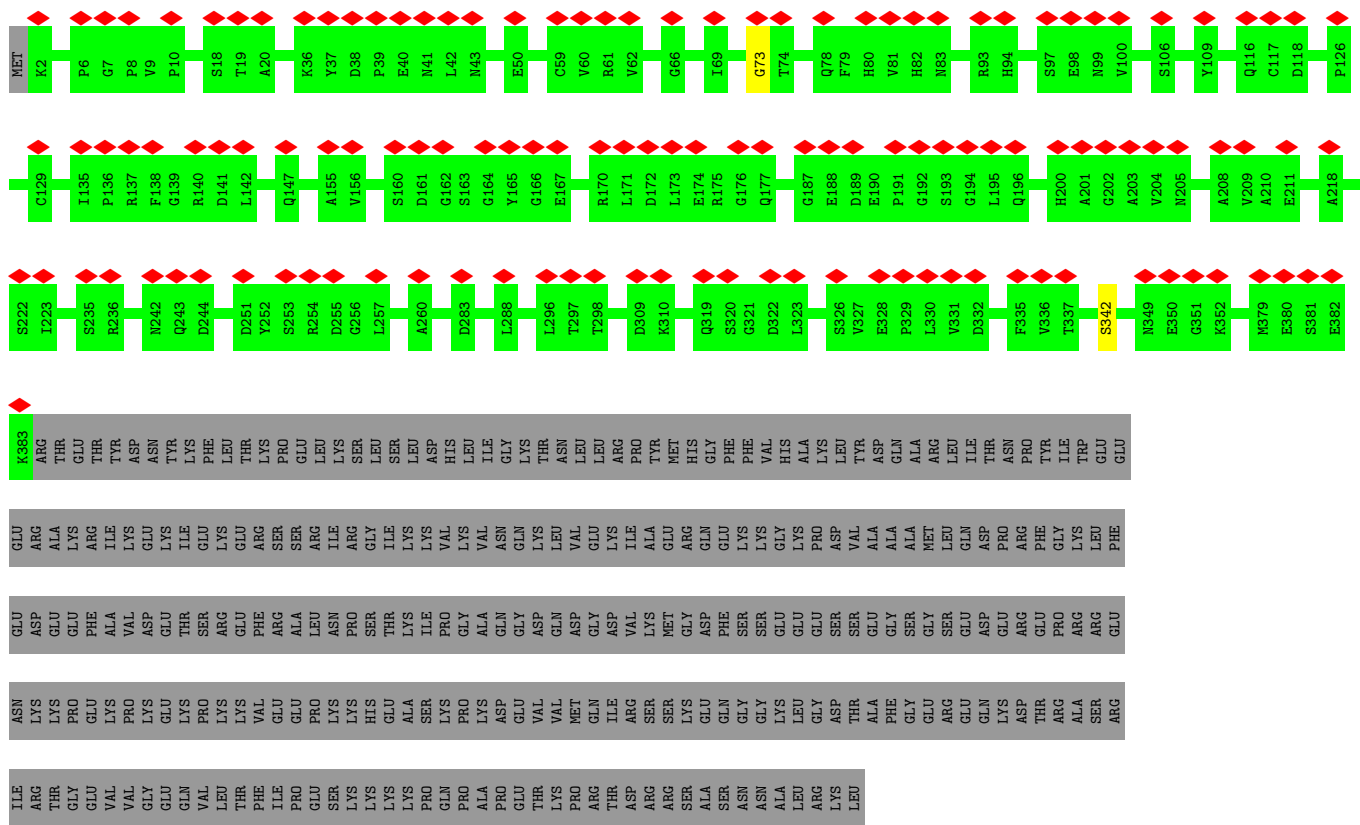

• Molecule 44: Utp20

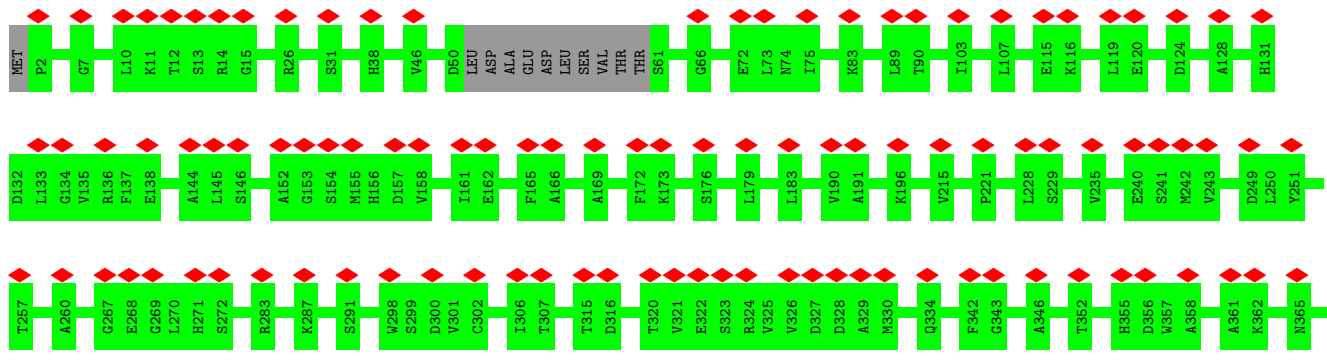
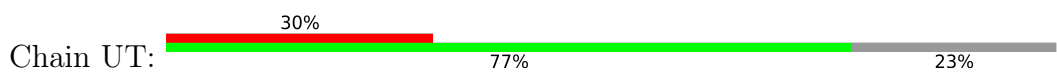

V1522	ALA	L368	SER	L1083	K1171	E1346	IYS	V1522
ASP	V369	H645	PRO	E1088	L1172	L1347	PRO	ALA
THR	S370	E946	PHE	P1089	E1175	Q1348	T1427	ASP
CYS	L371	A552	LEU	L1094	S1176	R1349	L1428	LEU
LEU	G372	E553	LEU	L1094	S1181	K1350	D1429	THR
VAL	T373	V554	LEU	C1101	A1182	V1351	Q1430	CYS
PRO	Q374	L555	LEU	L1102	R1185	Y1352	P1433	VAL
GLU	A375	A375	GLU	C1106	A1188	S1353	L1434	GLU
SER	K376	P471	GLU	R1107	T1189	T1354	V1435	SER
ASP	E379	E475	GLU	K1108	A1190	F1359	H1436	ASP
SER	V380	S476	GLU	L1109	W1190	G1360	L1437	SER
ASP	M381	G477	ASP	L1109	S1191	F1361	M1443	ASP
GLU	G478	G478	ILE	GLY	S1192	F1362	Q1443	GLU
ALA	G479	L479	VAL	VAL	S1192	K1363	E1446	ALA
PHE	L480	P480	SER	ALA	P1198	D1364	E1447	PHE
PHE	A481	A481	ALA	ALA	F1199	K1365	E1447	PHE
HIS	R400	ASP	GLU	GLU	F1199	Q1369	A1456	HIS
PRO	D404	GLU	PRO	GLU	F1199	D1376	D1457	PRO
MET	A405	N575	PRO	GLU	L1200	V1377	A1456	MET
SER	L406	G483	GLY	GLU	V1202	F1378	D1457	SER
PRO	I407	S484	GLY	GLU	D1203	A1385	Q1475	PRO
PRO	P408	K485	GLY	GLY	V1204	Q1386	A1476	PRO
ASP	A409	E486	GLY	GLY	R1205	V1388	A1477	ASP
LEU	M410	I487	GLY	ILE	E1212	S1389	D1480	LEU
LEU	S411	F488	GLN	GLU	S1215	E1382	V1481	LEU
LEU	T412	P488	ILE	GLU	I1216	W1384	L482	LEU
LEU	Q414	P489	GLU	GLU	E1217	A1385	A1483	LEU
LEU	T415	D496	GLU	GLU	K1218	Q1386	M1484	LEU
PRO	T418	D507	GLU	GLU	D1229	S1389	I1485	PRO
PHE	K419	T508	GLY	GLU	I1230	S1391	I1486	PHE
PRO	E420	PHE	GLY	GLU	L1231	S1391	I1487	PRO
PRO	M423	PRO	GLY	GLY	Q1303	D1304	P1488	PRO
GLY	K424	GLY	GLY	GLY	D1304	M305	A1489	GLY
PHE	D435	PHE	GLY	GLY	I1235	L1306	I1490	PHE
GLY	Q436	GLY	GLY	GLY	N1236	E1307	I1491	GLY
LYS	M437	LYS	GLY	GLY	L1237	E1308	A1492	LYS
LYS	A438	ASP	GLY	GLY	A1238	I1308	G1493	LYS
PRO	E439	PRO	GLY	GLY	E1242	L1317	S1494	PRO
THR	R440	THR	GLY	GLY	S1246	W1320	R1495	THR
THR	F441	THR	GLY	GLY	Q1246	F1247	L1496	THR
ARG	R442	ARG	GLY	GLY	N1248	V1324	P1497	ARG
ASP	K447	ASP	GLY	GLY	E1249	A1327	S1498	ASP
LYS	C527	LYS	GLY	GLY	L1328	I1328	E1499	LYS
LYS	L535	LYS	GLY	GLY	L1250	N1416	T1500	LYS
THR	T542	THR	GLY	GLY	I1251	S1417	R1507	THR
PRO	V543	PRO	GLY	GLY	I1418	I1418	L1516	PRO
SER	H544	SER	GLY	GLY	T1253	T1419	E1520	SER
GLY	P545	GLY	GLY	GLY	E1254	K1420	L1521	GLY
ALA	S546	ALA	GLY	GLY	L1255	ASP		ALA
GLU	T547	GLU	GLY	GLY	L1256	ARG		GLU
GLU	N548	GLU	GLY	GLY	D1257	ASP		GLU
					N1259			

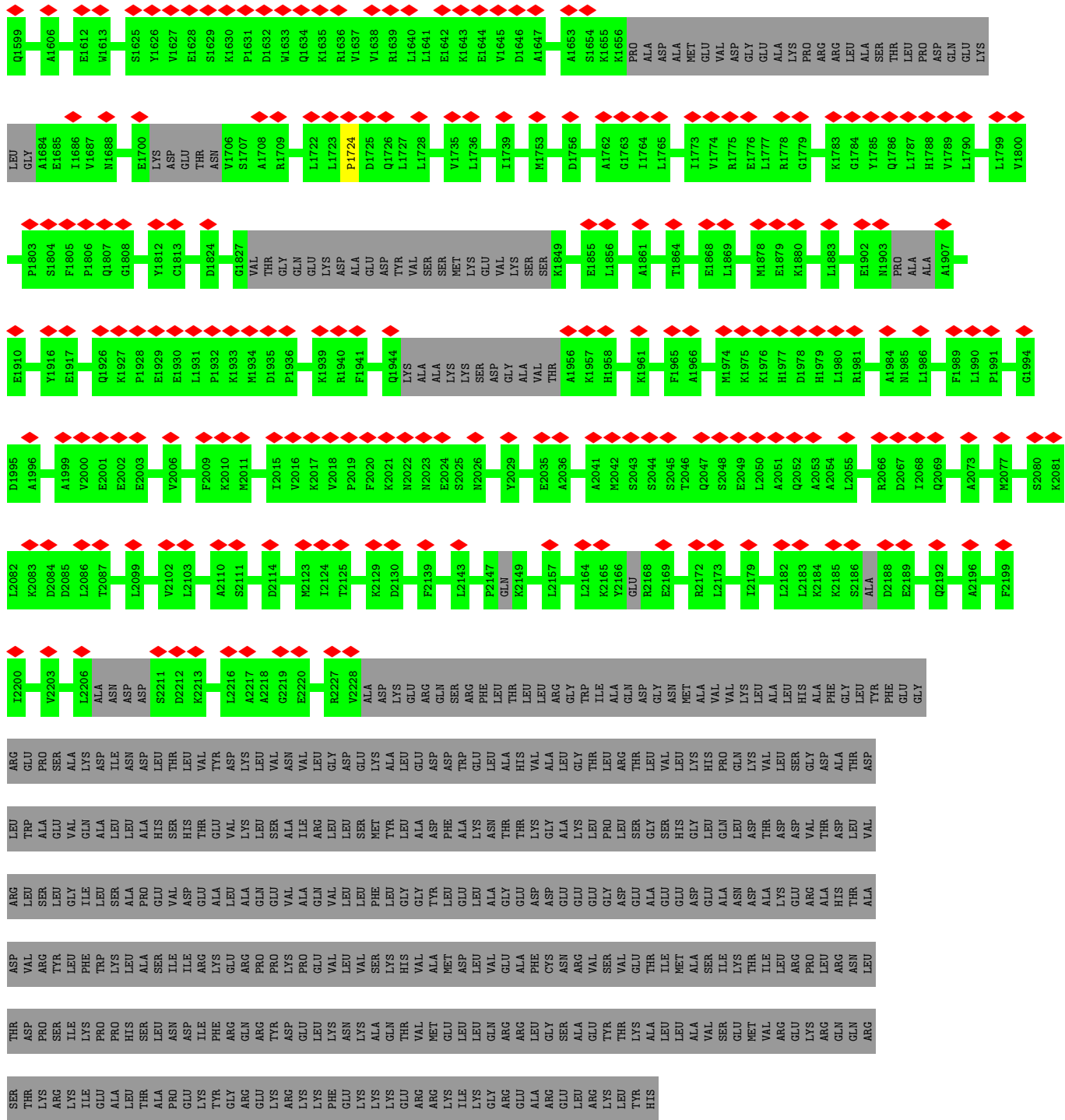

● Molecule 45: Bfr2

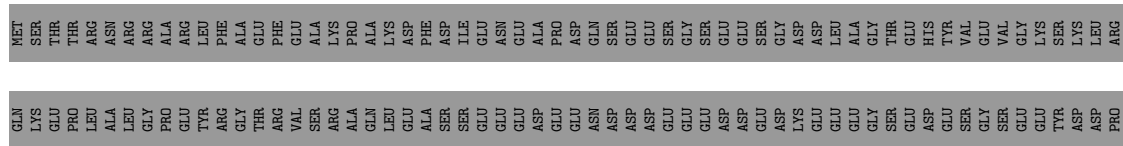

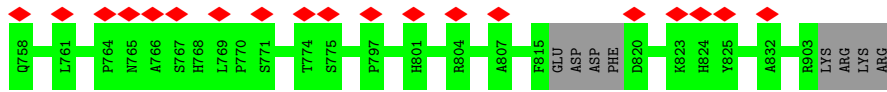
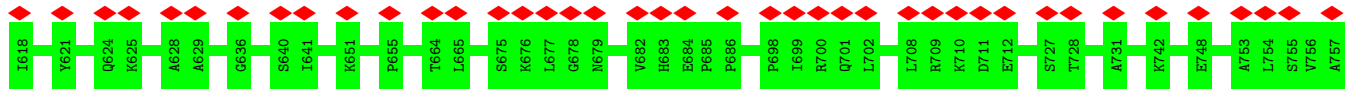

• Molecule 47: Utp4

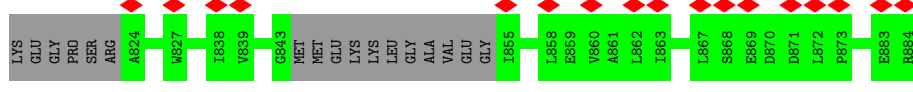
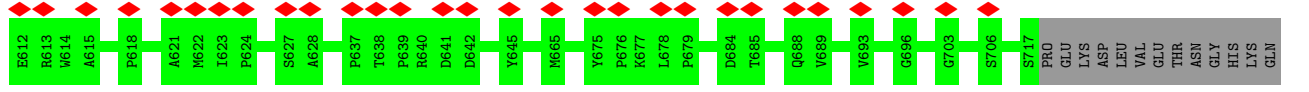
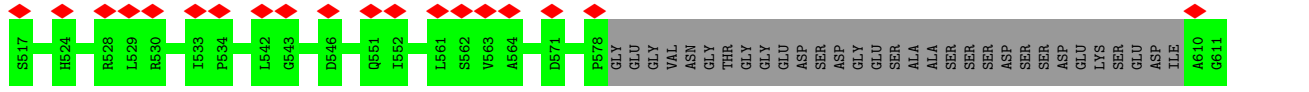
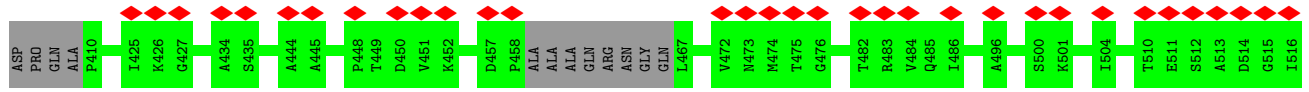
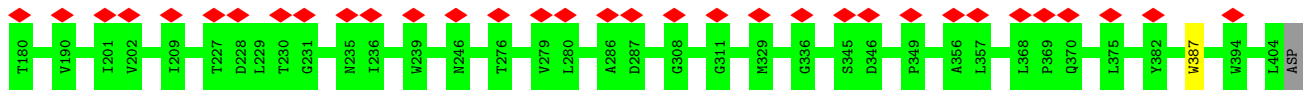
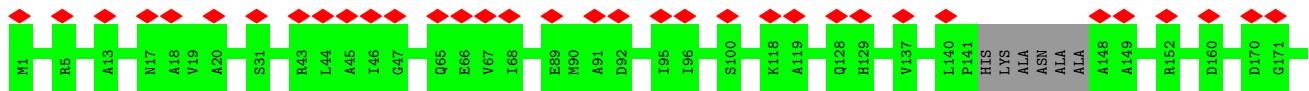
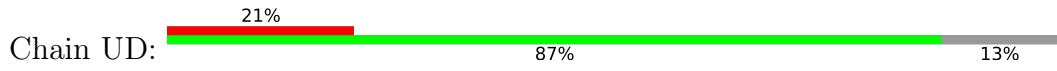

• Molecule 48: UTP10

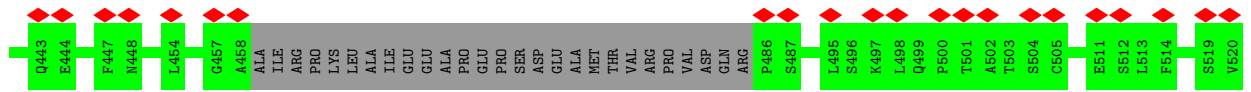
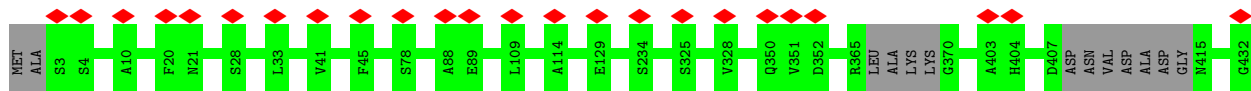

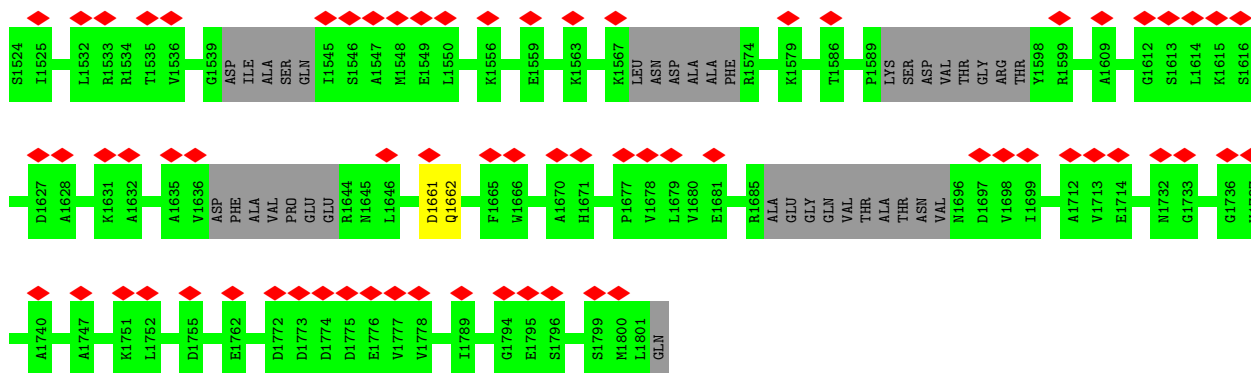

• Molecule 49: Utp15

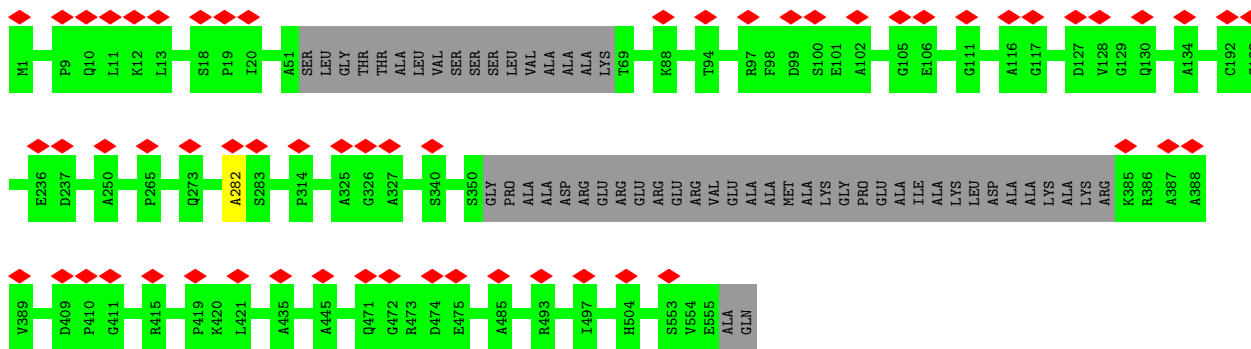
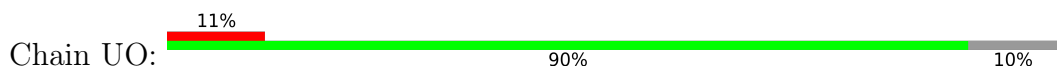

• Molecule 50: Utp17

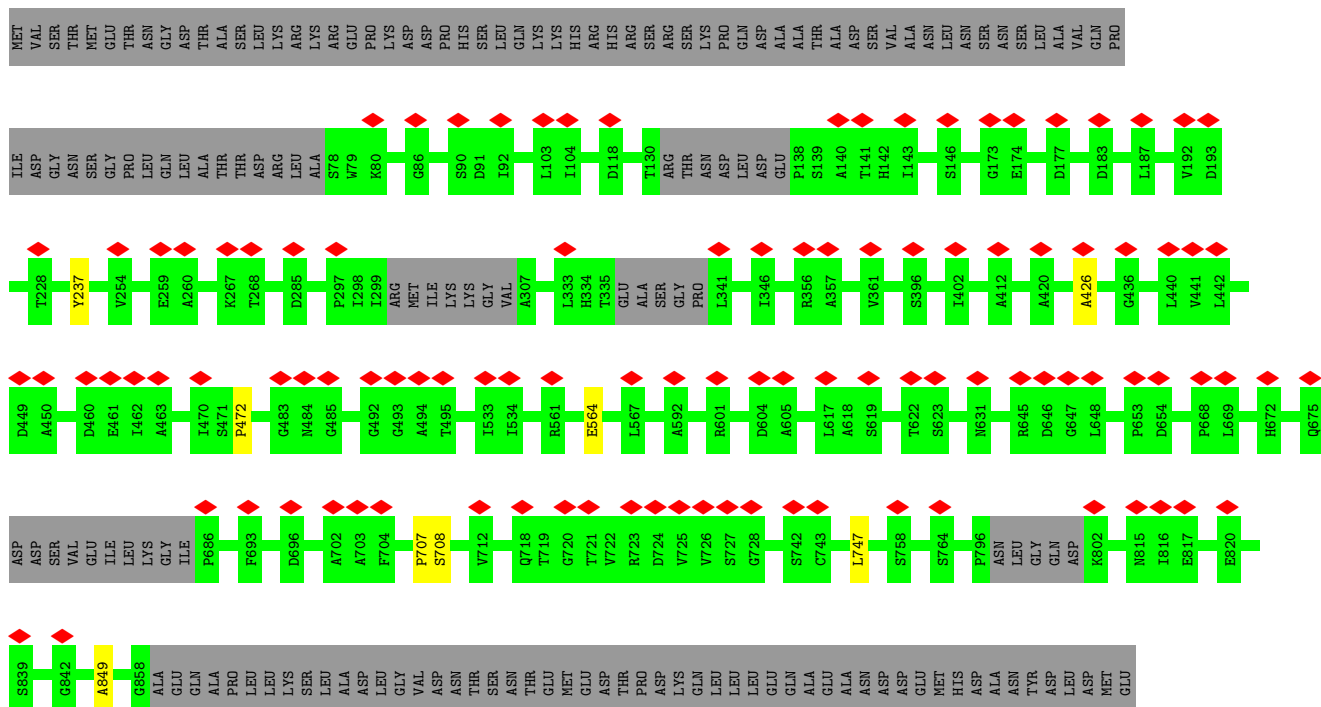
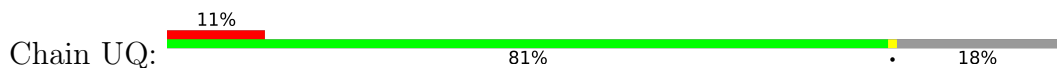

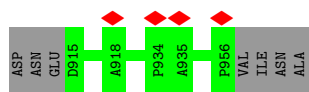

• Molecule 51: Enp1

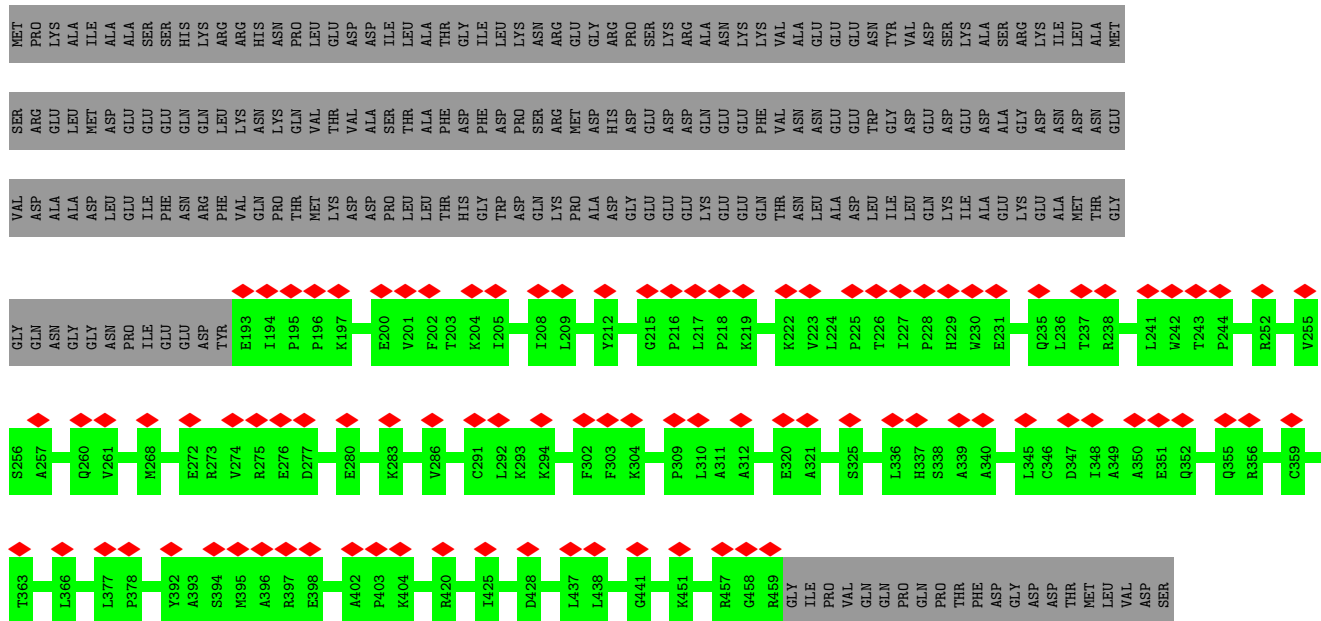

• Molecule 52: Utp5

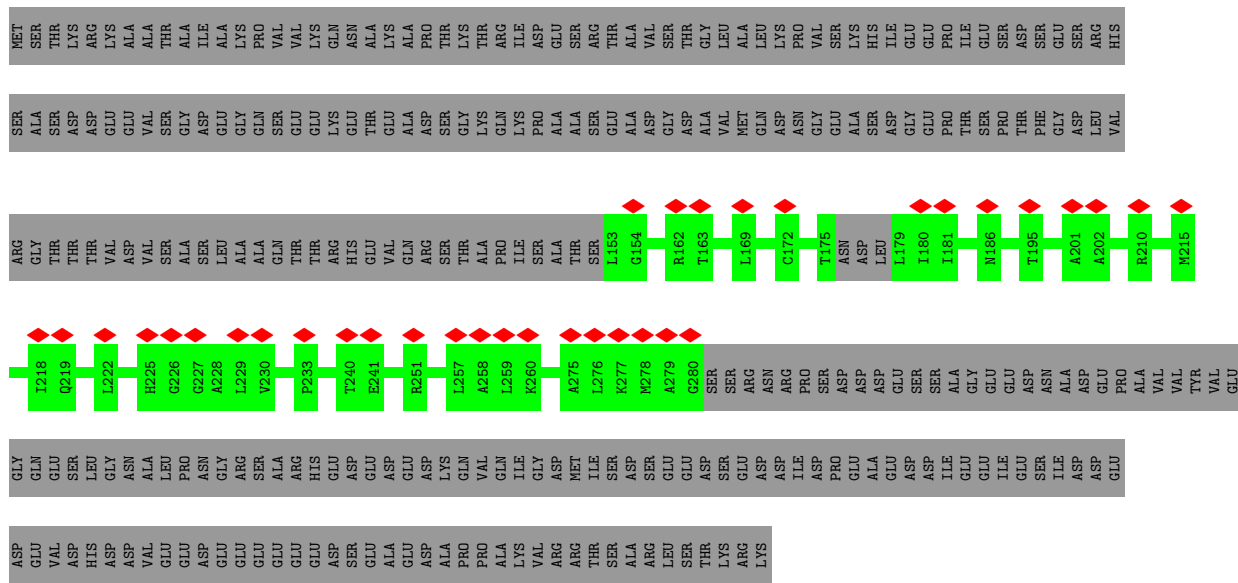

• Molecule 52: Utp5



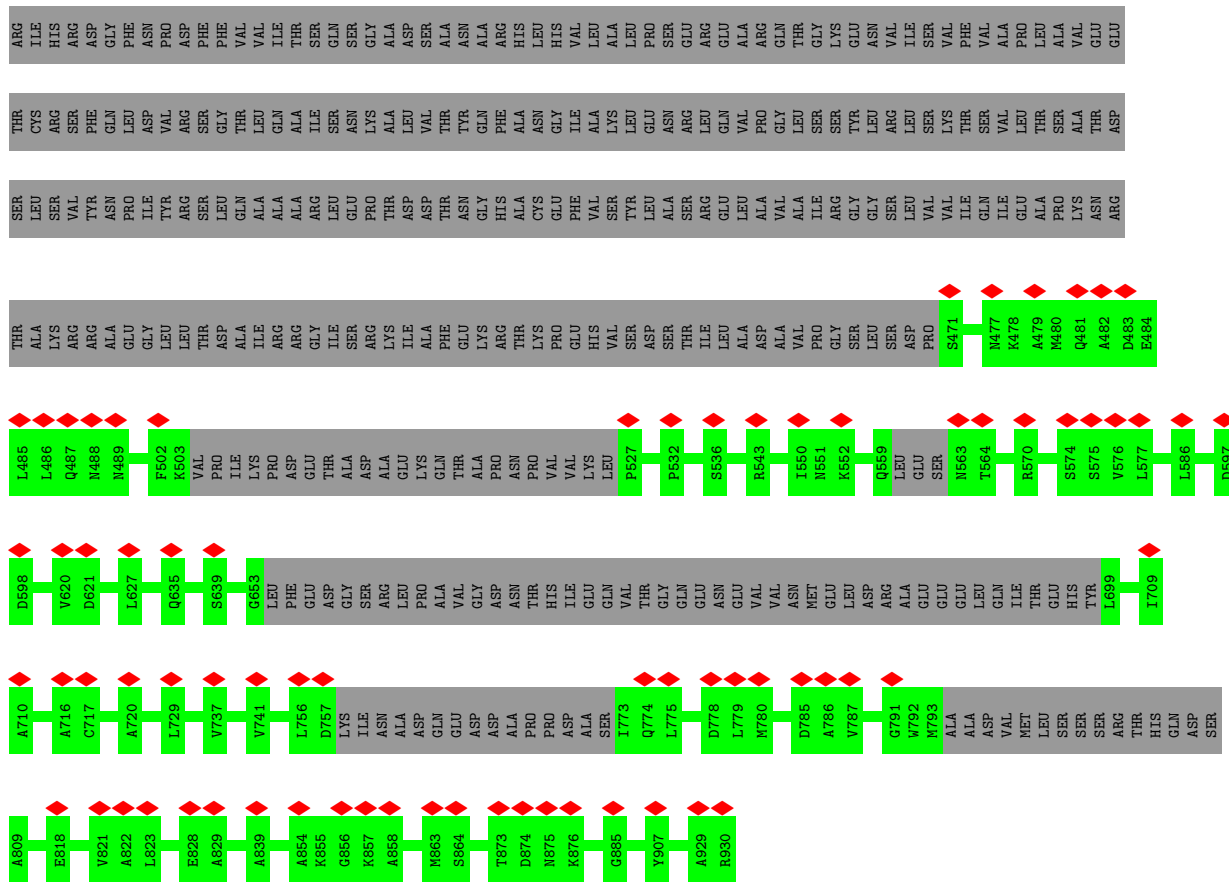

• Molecule 55: Noc4

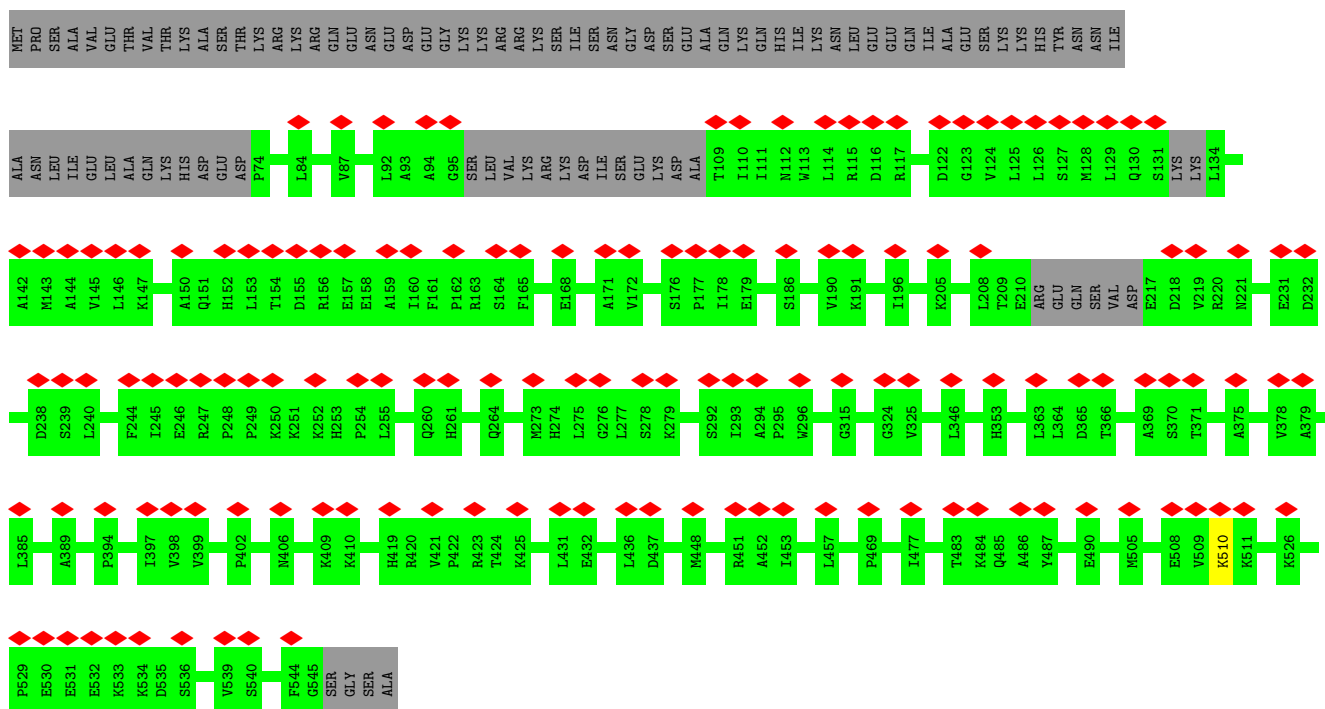
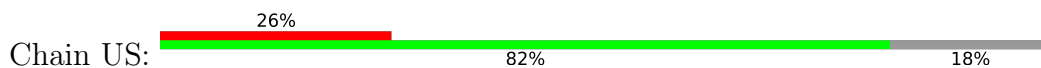

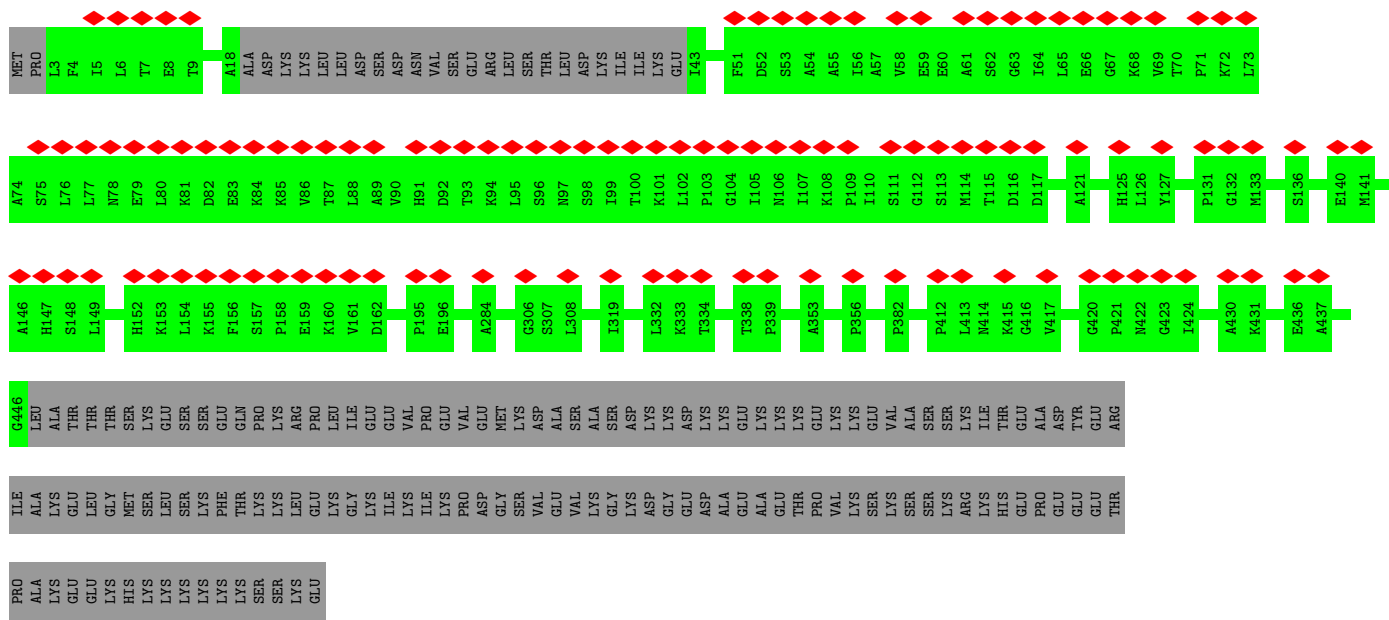

• Molecule 59: Snu13

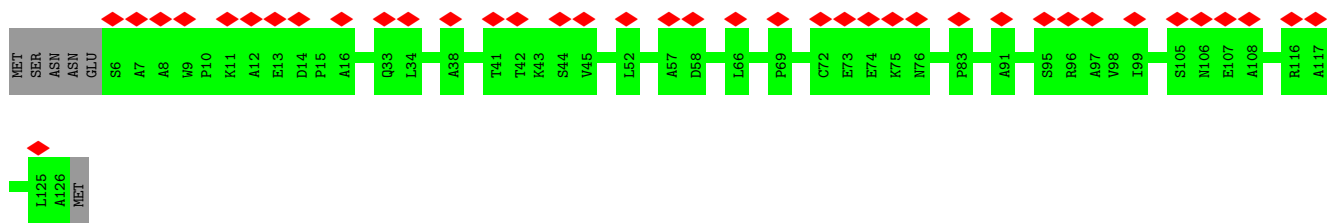

• Molecule 59: Snu13

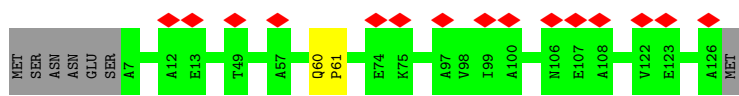

• Molecule 60: Rrp9

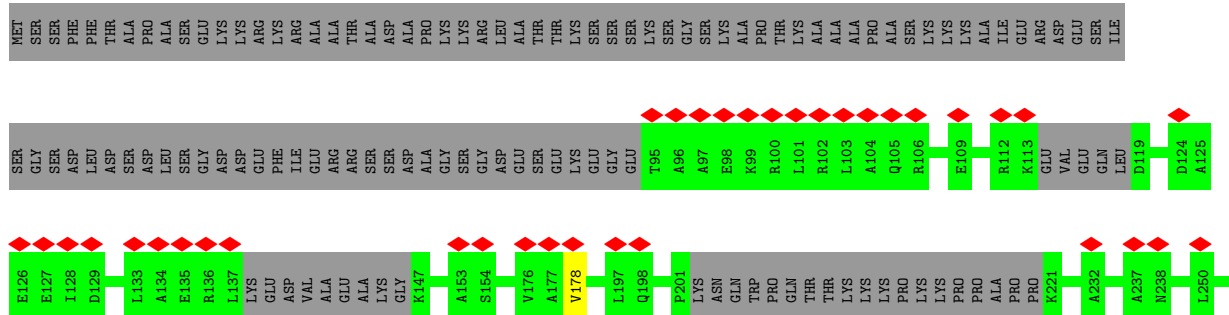

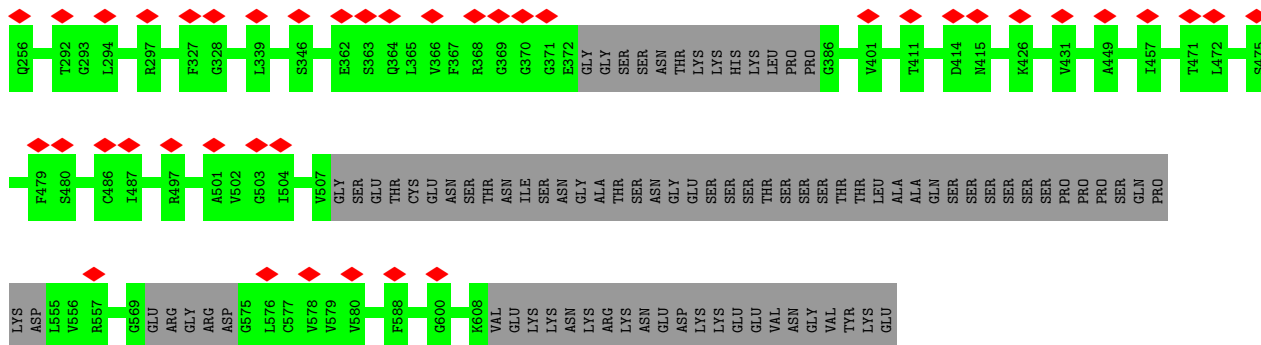

• Molecule 61: Fcf2

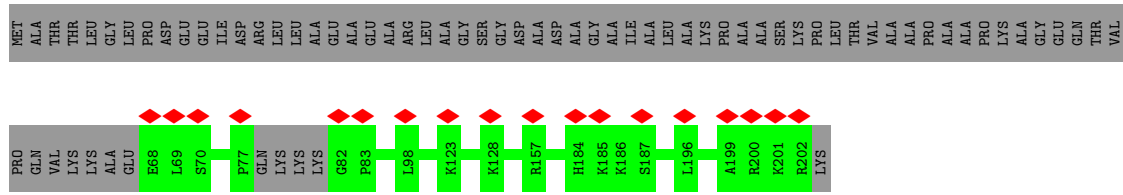

• Molecule 62: U3 snoRNA

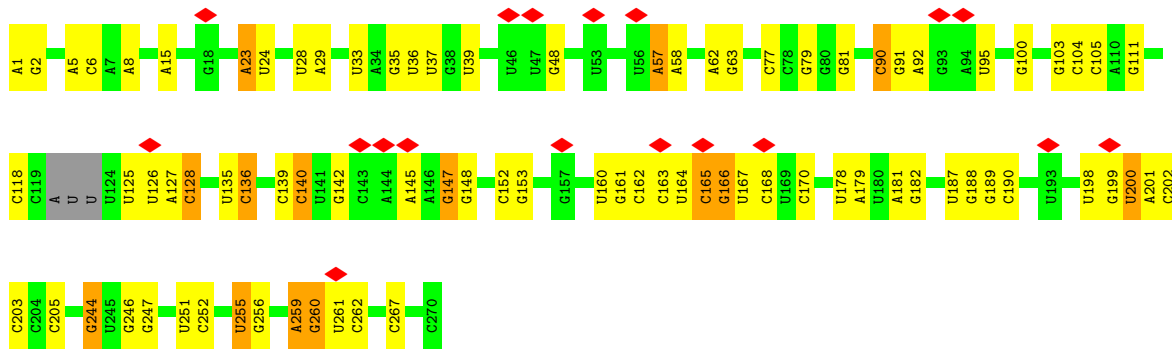

• Molecule 63: 40S ribosomal protein S19-like protein

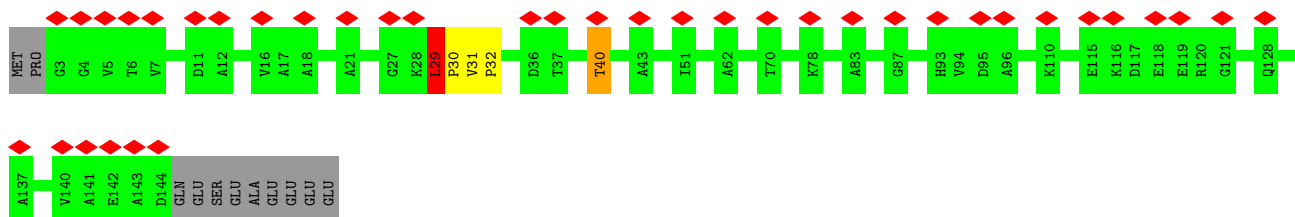
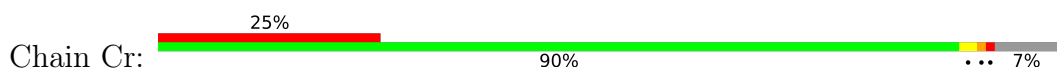

4 Experimental information

Property	Value	Source
EM reconstruction method	SINGLE PARTICLE	Depositor
Imposed symmetry	POINT, C1	Depositor
Number of particles used	9041	Depositor
Resolution determination method	FSC 0.143 CUT-OFF	Depositor
CTF correction method	PHASE FLIPPING AND AMPLITUDE CORRECTION	Depositor
Microscope	FEI TITAN KRIOS	Depositor
Voltage (kV)	300	Depositor
Electron dose ($e^-/\text{\AA}^2$)	28	Depositor
Minimum defocus (nm)	Not provided	
Maximum defocus (nm)	Not provided	
Magnification	Not provided	
Image detector	FEI FALCON II (4k x 4k)	Depositor
Maximum map value	0.171	Depositor
Minimum map value	-0.104	Depositor
Average map value	0.001	Depositor
Map value standard deviation	0.008	Depositor
Recommended contour level	0.03	Depositor
Map size (Å)	520.32, 520.32, 520.32	wwPDB
Map dimensions	480, 480, 480	wwPDB
Map angles (°)	90.0, 90.0, 90.0	wwPDB
Pixel spacing (Å)	1.084, 1.084, 1.084	Depositor

5 Model quality i

5.1 Standard geometry i

Bond lengths and bond angles in the following residue types are not validated in this section:
ZN

The Z score for a bond length (or angle) is the number of standard deviations the observed value is removed from the expected value. A bond length (or angle) with $|Z| > 5$ is considered an outlier worth inspection. RMSZ is the root-mean-square of all Z scores of the bond lengths (or angles).

Mol	Chain	Bond lengths		Bond angles	
		RMSZ	# Z >5	RMSZ	# Z >5
1	UA	0.35	0/4134	0.61	1/5749 (0.0%)
2	UC	0.33	0/360	0.50	0/497
3	UF	0.29	0/1641	0.48	0/2286
4	UG	0.34	0/2359	0.58	0/3279
5	UK	0.32	0/1067	0.44	0/1480
6	UL	0.31	0/3868	0.59	0/5372
7	UM	0.28	0/3590	0.57	0/4981
8	UN	0.32	0/877	0.52	0/1220
9	UR	0.33	0/2193	0.55	0/3040
10	UU	0.34	0/4418	0.57	0/6124
11	UX	0.32	0/941	0.56	0/1311
12	CJ	0.33	0/889	0.51	0/1240
13	CK	0.35	0/1471	0.57	0/2050
14	CL	0.31	0/1139	0.49	0/1582
15	CM	0.34	0/2200	0.59	0/3064
16	CN	0.29	0/1120	0.51	0/1560
16	CO	0.29	0/1065	0.56	0/1483
17	CP	0.30	0/993	0.54	0/1381
18	CQ	0.26	0/862	0.50	0/1197
19	Ca	0.30	0/1114	0.58	0/1552
20	Cc	0.29	0/951	0.49	0/1324
21	Ce	0.32	0/784	0.62	1/1089 (0.1%)
22	Cg	0.32	0/784	0.50	0/1090
23	Ch	0.57	0/740	0.76	0/1029
24	Ci	0.31	0/562	0.50	0/778
25	Cj	0.32	0/621	0.56	0/863
26	Cm	0.30	0/618	0.54	0/856
27	Cn	0.30	0/467	0.54	0/644
28	Cp	0.31	0/299	0.52	0/414
29	Cq	0.70	0/399	1.23	1/554 (0.2%)
30	CU	0.27	0/867	0.52	0/1202
31	C1	0.61	5/29104 (0.0%)	1.24	309/45308 (0.7%)

Mol	Chain	Bond lengths		Bond angles	
		RMSZ	# Z >5	RMSZ	# Z >5
32	UV	0.32	0/5242	0.59	1/7299 (0.0%)
33	CV	0.47	1/730 (0.1%)	0.76	3/1014 (0.3%)
34	Cl	0.27	0/394	0.56	0/547
35	CH	0.32	0/1899	0.55	0/2628
36	CI	0.33	0/4056	0.55	0/5641
37	CR	0.30	0/3748	0.63	0/5209
37	CS	0.30	0/3748	0.63	0/5209
38	Cb	0.29	0/1139	0.58	0/1581
39	Cd	0.31	0/1111	0.54	0/1543
40	Cf	0.31	0/850	0.55	0/1176
41	Ck	0.27	0/689	0.55	0/956
42	Co	0.31	0/452	0.57	0/627
43	CW	0.30	0/1879	0.62	0/2611
44	UT	0.30	0/9990	0.54	0/13904
45	CZ	0.29	0/206	0.64	0/285
46	UB	0.29	0/2515	0.48	0/3500
47	UD	0.31	0/3790	0.56	0/5255
48	UJ	0.29	0/5391	0.52	0/7498
49	UO	0.32	0/2483	0.56	0/3451
50	UQ	0.32	0/3892	0.61	2/5410 (0.0%)
51	CX	0.26	0/1324	0.48	0/1846
52	UE	0.29	0/614	0.50	0/851
52	UI	0.24	0/614	0.40	0/851
53	UP	0.29	0/264	0.54	0/365
54	UH	0.29	0/1766	0.50	0/2450
55	US	0.29	0/2241	0.52	0/3125
56	CA	0.33	0/1187	0.56	0/1646
56	CB	0.28	0/1090	0.52	0/1512
57	CC	0.31	0/1909	0.52	0/2655
58	CD	0.31	0/2071	0.52	0/2880
59	CE	0.34	0/600	0.54	0/836
59	CF	0.34	0/595	0.56	0/829
60	CG	0.30	0/2042	0.57	0/2829
61	CT	0.31	0/645	0.54	0/895
62	C2	0.65	0/5434	1.40	69/8459 (0.8%)
63	Cr	0.70	0/696	1.21	2/965 (0.2%)
All	All	0.41	6/149793 (0.0%)	0.80	389/213937 (0.2%)

Chiral center outliers are detected by calculating the chiral volume of a chiral center and verifying if the center is modelled as a planar moiety or with the opposite hand. A planarity outlier is detected by checking planarity of atoms in a peptide group, atoms in a mainchain group or atoms of a sidechain that are expected to be planar.

Mol	Chain	#Chirality outliers	#Planarity outliers
1	UA	0	1
6	UL	0	2
7	UM	0	4
9	UR	0	1
10	UU	0	3
13	CK	0	1
15	CM	0	1
16	CO	0	2
18	CQ	0	1
20	Cc	0	1
21	Ce	0	1
23	Ch	0	1
32	UV	0	3
33	CV	0	2
34	CI	0	1
35	CH	0	1
36	CI	0	2
37	CR	0	3
37	CS	0	3
38	Cb	0	1
43	CW	0	2
44	UT	0	10
47	UD	0	1
48	UJ	0	2
49	UO	0	1
50	UQ	0	4
52	UE	0	1
55	US	0	1
56	CB	0	1
59	CF	0	1
60	CG	0	1
63	Cr	0	1
All	All	0	61

All (6) bond length outliers are listed below:

Mol	Chain	Res	Type	Atoms	Z	Observed(Å)	Ideal(Å)
31	C1	2076	C	C1'-N1	5.83	1.57	1.48
31	C1	2094	G	C1'-N9	-5.69	1.38	1.46
31	C1	2075	U	C1'-N1	5.68	1.57	1.48
31	C1	1081	G	C2-N3	-5.57	1.28	1.32
33	CV	91	HIS	N-CA	5.49	1.57	1.46
31	C1	2106	U	C1'-N1	5.30	1.56	1.48

All (389) bond angle outliers are listed below:

Mol	Chain	Res	Type	Atoms	Z	Observed(°)	Ideal(°)
62	C2	2	G	O5'-P-OP1	-30.50	74.10	110.70
62	C2	2	G	OP1-P-OP2	-27.22	78.76	119.60
62	C2	2	G	O5'-P-OP2	18.20	132.55	110.70
62	C2	1	A	OP1-P-O3'	13.82	135.61	105.20
62	C2	1	A	OP2-P-O3'	-13.12	76.34	105.20
31	C1	55	G	OP1-P-O3'	-12.21	78.34	105.20
31	C1	45	U	OP1-P-O3'	-11.39	80.14	105.20
31	C1	2168	U	N3-C2-O2	-10.39	114.93	122.20
31	C1	1222	C	N1-C2-O2	10.19	125.01	118.90
31	C1	758	U	N3-C2-O2	-9.97	115.22	122.20
62	C2	140	C	N3-C2-O2	-9.83	115.02	121.90
31	C1	2168	U	N1-C2-O2	9.68	129.58	122.80
31	C1	1662	C	N3-C2-O2	-9.50	115.25	121.90
62	C2	128	C	C6-N1-C2	-9.48	116.51	120.30
31	C1	1658	G	N3-C4-N9	-9.28	120.43	126.00
62	C2	200	U	C2-N1-C1'	9.28	128.84	117.70
31	C1	661	U	C2-N1-C1'	9.26	128.82	117.70
62	C2	200	U	N1-C2-O2	9.26	129.28	122.80
31	C1	1658	G	C5-C6-O6	9.26	134.16	128.60
31	C1	2217	C	N1-C2-O2	9.15	124.39	118.90
31	C1	45	U	OP2-P-O3'	-9.15	85.07	105.20
31	C1	1550	U	C2-N1-C1'	9.10	128.62	117.70
62	C2	140	C	N1-C2-O2	9.10	124.36	118.90
62	C2	128	C	C5-C6-N1	9.07	125.53	121.00
31	C1	1027	C	N3-C2-O2	-8.95	115.64	121.90
31	C1	1658	G	N9-C4-C5	8.92	108.97	105.40
31	C1	692	U	N1-C2-O2	8.83	128.98	122.80
31	C1	1655	U	N3-C2-O2	-8.82	116.02	122.20
31	C1	927	C	N3-C2-O2	-8.81	115.73	121.90
62	C2	200	U	N3-C2-O2	-8.75	116.08	122.20
31	C1	2217	C	C2-N1-C1'	8.66	128.33	118.80
31	C1	922	C	N3-C2-O2	-8.62	115.86	121.90
62	C2	136	C	N1-C2-O2	8.61	124.07	118.90
31	C1	850	A	N1-C6-N6	-8.59	113.45	118.60
31	C1	915	G	N3-C4-N9	-8.48	120.91	126.00
31	C1	1486	G	C4-N9-C1'	8.47	137.51	126.50
31	C1	661	U	N1-C2-O2	8.44	128.71	122.80
31	C1	692	U	N3-C2-O2	-8.44	116.29	122.20
31	C1	683	C	C2-N1-C1'	8.42	128.06	118.80
31	C1	2202	C	N1-C2-O2	8.38	123.93	118.90
31	C1	1547	C	N1-C2-O2	8.36	123.92	118.90
31	C1	1222	C	C2-N1-C1'	8.27	127.89	118.80

Continued on next page...

Continued from previous page...

Mol	Chain	Res	Type	Atoms	Z	Observed(°)	Ideal(°)
31	C1	758	U	C2-N1-C1'	8.21	127.55	117.70
31	C1	661	U	N3-C2-O2	-8.14	116.50	122.20
31	C1	915	G	N9-C4-C5	8.05	108.62	105.40
31	C1	1222	C	N3-C2-O2	-7.93	116.35	121.90
31	C1	1081	G	N3-C2-N2	-7.93	114.35	119.90
31	C1	68	U	N1-C2-O2	7.91	128.33	122.80
62	C2	203	C	N3-C2-O2	-7.89	116.37	121.90
62	C2	103	G	N3-C4-C5	-7.82	124.69	128.60
31	C1	583	A	O5'-P-OP1	-7.81	98.67	105.70
62	C2	128	C	O4'-C1'-N1	7.79	114.43	108.20
31	C1	2210	U	N3-C2-O2	-7.77	116.76	122.20
62	C2	267	C	N3-C2-O2	-7.77	116.46	121.90
31	C1	1645	U	C2-N1-C1'	7.72	126.97	117.70
31	C1	915	G	N1-C6-O6	-7.72	115.27	119.90
31	C1	1645	U	N1-C2-O2	7.59	128.11	122.80
31	C1	2179	C	C2-N1-C1'	7.59	127.14	118.80
62	C2	6	C	C6-N1-C2	-7.56	117.28	120.30
31	C1	707	U	C2-N1-C1'	7.54	126.75	117.70
31	C1	1658	G	N1-C6-O6	-7.52	115.39	119.90
31	C1	1662	C	N1-C2-O2	7.49	123.39	118.90
31	C1	989	C	C2-N1-C1'	7.47	127.02	118.80
31	C1	1745	C	C5-C6-N1	7.44	124.72	121.00
31	C1	1625	G	N3-C4-N9	7.43	130.46	126.00
31	C1	776	C	N1-C2-O2	7.42	123.35	118.90
31	C1	1645	U	N3-C2-O2	-7.41	117.01	122.20
31	C1	768	C	C2-N1-C1'	7.40	126.94	118.80
31	C1	1512	C	C6-N1-C2	-7.40	117.34	120.30
31	C1	1120	C	C2-N1-C1'	7.39	126.93	118.80
62	C2	246	G	C4-N9-C1'	7.32	136.01	126.50
31	C1	1711	G	C4-N9-C1'	7.31	136.00	126.50
31	C1	1658	G	C4-C5-N7	-7.29	107.88	110.80
31	C1	56	C	OP1-P-OP2	7.28	130.53	119.60
62	C2	136	C	C2-N1-C1'	7.28	126.81	118.80
31	C1	915	G	C5-C6-O6	7.25	132.95	128.60
31	C1	1486	G	N3-C4-C5	-7.25	124.97	128.60
62	C2	139	C	N1-C2-O2	7.25	123.25	118.90
62	C2	139	C	N3-C2-O2	-7.19	116.87	121.90
31	C1	942	U	N3-C2-O2	-7.16	117.19	122.20
31	C1	1163	A	P-O3'-C3'	7.15	128.28	119.70
31	C1	2217	C	N3-C2-O2	-7.13	116.91	121.90
31	C1	46	C	OP1-P-OP2	7.13	130.29	119.60
31	C1	1666	C	N1-C2-O2	7.12	123.17	118.90

Continued on next page...

Continued from previous page...

Mol	Chain	Res	Type	Atoms	Z	Observed(°)	Ideal(°)
31	C1	989	C	C6-N1-C2	-7.12	117.45	120.30
31	C1	750	C	N1-C2-O2	7.03	123.12	118.90
31	C1	851	U	N3-C2-O2	-7.01	117.29	122.20
31	C1	622	U	N3-C2-O2	-7.00	117.30	122.20
62	C2	255	U	P-O3'-C3'	6.99	128.09	119.70
62	C2	252	C	N3-C2-O2	-6.98	117.02	121.90
31	C1	56	C	C2-N1-C1'	6.96	126.45	118.80
31	C1	34	C	N1-C2-O2	6.94	123.06	118.90
62	C2	260	G	C4-N9-C1'	6.90	135.47	126.50
62	C2	57	A	O4'-C1'-N9	6.90	113.72	108.20
31	C1	1549	U	N3-C4-C5	6.88	118.73	114.60
62	C2	161	G	C4-N9-C1'	6.87	135.43	126.50
31	C1	1114	C	N1-C2-O2	6.86	123.02	118.90
33	CV	92	SER	CB-CA-C	-6.86	97.07	110.10
31	C1	1471	U	C2-N1-C1'	6.85	125.92	117.70
31	C1	34	C	N3-C2-O2	-6.84	117.11	121.90
31	C1	2202	C	N3-C2-O2	-6.82	117.13	121.90
62	C2	103	G	N3-C4-N9	6.81	130.09	126.00
31	C1	581	C	N3-C2-O2	-6.81	117.13	121.90
62	C2	260	G	N3-C4-N9	6.80	130.08	126.00
31	C1	1487	G	O4'-C1'-N9	6.77	113.61	108.20
31	C1	33	C	N3-C2-O2	-6.76	117.17	121.90
31	C1	1113	C	N1-C2-O2	6.76	122.96	118.90
62	C2	259	A	O4'-C1'-N9	6.73	113.58	108.20
31	C1	1547	C	C5-C6-N1	6.72	124.36	121.00
32	UV	1058	TYR	CB-CA-C	-6.70	97.01	110.40
31	C1	1471	U	C5-C4-O4	-6.67	121.90	125.90
31	C1	68	U	N3-C2-O2	-6.66	117.54	122.20
31	C1	581	C	N1-C2-O2	6.66	122.89	118.90
31	C1	1486	G	C8-N9-C1'	-6.65	118.36	127.00
31	C1	1046	G	C5-C6-O6	6.61	132.57	128.60
31	C1	769	C	C2-N1-C1'	6.59	126.06	118.80
31	C1	1486	G	N7-C8-N9	6.59	116.39	113.10
31	C1	1486	G	N3-C4-N9	6.58	129.95	126.00
33	CV	92	SER	N-CA-CB	6.57	120.36	110.50
31	C1	1666	C	C5-C6-N1	6.54	124.27	121.00
31	C1	984	A	C2-N3-C4	6.53	113.86	110.60
31	C1	1745	C	C6-N1-C2	-6.53	117.69	120.30
62	C2	260	G	N3-C4-C5	-6.53	125.33	128.60
62	C2	202	C	N1-C2-O2	6.52	122.81	118.90
31	C1	989	C	C5-C6-N1	6.51	124.25	121.00
62	C2	147	G	N3-C4-N9	6.49	129.89	126.00

Continued on next page...

Continued from previous page...

Mol	Chain	Res	Type	Atoms	Z	Observed(°)	Ideal(°)
31	C1	661	U	C5-C6-N1	6.48	125.94	122.70
31	C1	1711	G	N3-C4-N9	6.47	129.88	126.00
31	C1	915	G	C8-N9-C1'	6.46	135.40	127.00
31	C1	1625	G	N3-C4-C5	-6.46	125.37	128.60
62	C2	267	C	C6-N1-C2	-6.46	117.72	120.30
31	C1	2179	C	N1-C2-O2	6.45	122.77	118.90
1	UA	662	GLY	C-N-CA	6.44	137.81	121.70
31	C1	1666	C	C2-N1-C1'	6.43	125.87	118.80
31	C1	776	C	C2-N1-C1'	6.42	125.86	118.80
31	C1	2086	A	N1-C6-N6	6.42	122.45	118.60
31	C1	1547	C	C2-N1-C1'	6.39	125.83	118.80
63	Cr	40	THR	N-CA-CB	6.39	122.45	110.30
31	C1	1068	C	C6-N1-C2	-6.39	117.74	120.30
31	C1	2045	G	C8-N9-C4	6.39	108.95	106.40
31	C1	692	U	C2-N1-C1'	6.38	125.36	117.70
31	C1	68	U	C5-C6-N1	6.36	125.88	122.70
31	C1	1114	C	N3-C2-O2	-6.35	117.45	121.90
62	C2	161	G	N3-C4-N9	6.35	129.81	126.00
31	C1	1448	A	C5-C6-N1	6.34	120.87	117.70
31	C1	758	U	N1-C2-O2	6.34	127.24	122.80
31	C1	915	G	C6-C5-N7	6.34	134.20	130.40
31	C1	18	G	N3-C4-C5	-6.33	125.43	128.60
31	C1	581	C	C2-N1-C1'	6.33	125.76	118.80
31	C1	68	U	C2-N1-C1'	6.33	125.29	117.70
31	C1	593	G	P-O3'-C3'	6.32	127.29	119.70
31	C1	1550	U	C6-N1-C1'	-6.32	112.35	121.20
31	C1	860	C	C2-N1-C1'	-6.31	111.86	118.80
31	C1	683	C	N1-C2-O2	6.30	122.68	118.90
31	C1	683	C	C6-N1-C2	-6.30	117.78	120.30
31	C1	1747	A	C6-N1-C2	-6.27	114.84	118.60
62	C2	246	G	C8-N9-C1'	-6.25	118.87	127.00
31	C1	63	C	N1-C2-O2	6.21	122.63	118.90
62	C2	23	A	P-O3'-C3'	6.21	127.15	119.70
62	C2	105	C	C5-C6-N1	6.19	124.10	121.00
31	C1	1711	G	C8-N9-C1'	-6.19	118.95	127.00
31	C1	1658	G	C6-C5-N7	6.19	134.11	130.40
31	C1	622	U	N1-C2-O2	6.19	127.13	122.80
62	C2	161	G	C6-C5-N7	-6.17	126.70	130.40
31	C1	1222	C	C6-N1-C2	-6.17	117.83	120.30
31	C1	2113	U	O5'-P-OP2	-6.17	100.15	105.70
31	C1	1638	G	P-O3'-C3'	6.14	127.07	119.70
31	C1	425	C	C6-N1-C2	-6.11	117.86	120.30

Continued on next page...

Continued from previous page...

Mol	Chain	Res	Type	Atoms	Z	Observed(°)	Ideal(°)
31	C1	850	A	C6-N1-C2	-6.11	114.94	118.60
31	C1	1745	C	C2-N1-C1'	6.11	125.52	118.80
31	C1	1167	C	C6-N1-C2	-6.10	117.86	120.30
31	C1	56	C	N1-C2-O2	6.09	122.56	118.90
31	C1	2217	C	C6-N1-C1'	-6.08	113.50	120.80
31	C1	1630	C	N3-C2-O2	-6.08	117.65	121.90
31	C1	1017	C	P-O3'-C3'	6.07	126.99	119.70
31	C1	910	G	C5-C6-O6	6.07	132.24	128.60
31	C1	2045	G	N9-C4-C5	-6.04	102.98	105.40
31	C1	18	G	C4-N9-C1'	6.04	134.35	126.50
31	C1	1245	C	N1-C2-O2	6.04	122.52	118.90
31	C1	1712	C	P-O3'-C3'	6.03	126.94	119.70
31	C1	18	G	N3-C4-N9	6.03	129.62	126.00
31	C1	1711	G	N3-C4-C5	-6.02	125.59	128.60
31	C1	1234	C	C2-N1-C1'	6.01	125.41	118.80
31	C1	850	A	C5-C6-N1	6.01	120.70	117.70
31	C1	1485	A	P-O3'-C3'	6.01	126.91	119.70
62	C2	103	G	C2-N3-C4	6.01	114.90	111.90
31	C1	2210	U	C5-C4-O4	6.00	129.50	125.90
31	C1	1549	U	N3-C4-O4	-6.00	115.20	119.40
31	C1	1486	G	C8-N9-C4	-6.00	104.00	106.40
31	C1	2194	A	C8-N9-C4	-6.00	103.40	105.80
31	C1	909	G	N3-C4-N9	5.99	129.59	126.00
62	C2	161	G	C8-N9-C1'	-5.99	119.22	127.00
31	C1	21	C	N3-C2-O2	-5.97	117.72	121.90
31	C1	684	U	P-O3'-C3'	5.97	126.86	119.70
31	C1	886	U	N3-C2-O2	-5.97	118.02	122.20
31	C1	1547	C	C6-N1-C2	-5.96	117.92	120.30
31	C1	1661	C	C2-N3-C4	-5.96	116.92	119.90
31	C1	802	A	P-O3'-C3'	5.95	126.84	119.70
31	C1	636	C	C2-N1-C1'	5.95	125.34	118.80
31	C1	1451	G	N9-C4-C5	-5.94	103.03	105.40
31	C1	55	G	OP2-P-O3'	-5.93	92.16	105.20
62	C2	260	G	C8-N9-C1'	-5.90	119.32	127.00
62	C2	6	C	C5-C6-N1	5.90	123.95	121.00
62	C2	200	U	C6-N1-C1'	-5.89	112.96	121.20
31	C1	1165	U	C2-N1-C1'	5.88	124.76	117.70
31	C1	722	U	N1-C2-O2	5.88	126.92	122.80
62	C2	136	C	C5-C6-N1	5.88	123.94	121.00
31	C1	2179	C	C6-N1-C1'	-5.87	113.75	120.80
31	C1	1113	C	N3-C2-O2	-5.87	117.79	121.90
31	C1	1448	A	C6-N1-C2	-5.86	115.08	118.60

Continued on next page...

Continued from previous page...

Mol	Chain	Res	Type	Atoms	Z	Observed(°)	Ideal(°)
31	C1	1458	U	C2-N1-C1'	5.85	124.72	117.70
31	C1	1639	U	C2-N1-C1'	5.84	124.71	117.70
31	C1	1560	C	N1-C2-O2	5.84	122.40	118.90
62	C2	6	C	N1-C2-O2	5.82	122.39	118.90
31	C1	776	C	N3-C2-O2	-5.82	117.83	121.90
31	C1	2069	G	C5-N7-C8	-5.81	101.40	104.30
31	C1	927	C	N1-C2-O2	5.80	122.38	118.90
31	C1	2210	U	N1-C2-O2	5.80	126.86	122.80
31	C1	2143	U	N3-C2-O2	-5.79	118.15	122.20
62	C2	244	G	C5-C6-O6	5.79	132.07	128.60
31	C1	886	U	C2-N1-C1'	5.79	124.64	117.70
31	C1	770	C	C2-N1-C1'	5.78	125.16	118.80
31	C1	1120	C	C6-N1-C2	-5.78	117.99	120.30
31	C1	2177	G	P-O3'-C3'	5.78	126.64	119.70
31	C1	1666	C	C6-N1-C2	-5.77	117.99	120.30
31	C1	1451	G	N3-C4-N9	5.76	129.46	126.00
31	C1	2358	U	N3-C2-O2	-5.76	118.17	122.20
31	C1	727	G	N3-C4-N9	5.76	129.45	126.00
31	C1	3	G	N3-C4-N9	-5.75	122.55	126.00
31	C1	942	U	N1-C2-O2	5.75	126.83	122.80
31	C1	1458	U	N1-C2-O2	5.75	126.82	122.80
31	C1	886	U	N1-C2-O2	5.75	126.82	122.80
31	C1	2358	U	C2-N1-C1'	5.75	124.59	117.70
31	C1	1002	G	O5'-P-OP2	-5.74	100.53	105.70
31	C1	2069	G	C8-N9-C4	-5.74	104.11	106.40
31	C1	1046	G	N1-C6-O6	-5.73	116.46	119.90
31	C1	1639	U	N1-C2-O2	5.71	126.80	122.80
31	C1	2203	C	N1-C2-O2	5.70	122.32	118.90
31	C1	1560	C	N3-C2-O2	-5.70	117.91	121.90
62	C2	105	C	C6-N1-C2	-5.69	118.02	120.30
31	C1	922	C	C6-N1-C2	-5.67	118.03	120.30
31	C1	1511	A	C2-N3-C4	5.67	113.44	110.60
62	C2	152	C	C6-N1-C2	-5.67	118.03	120.30
31	C1	661	U	C6-N1-C1'	-5.66	113.27	121.20
31	C1	915	G	C4-C5-N7	-5.66	108.53	110.80
31	C1	1252	G	N1-C6-O6	-5.66	116.50	119.90
31	C1	750	C	N3-C2-O2	-5.65	117.95	121.90
31	C1	56	C	C5-C6-N1	5.64	123.82	121.00
62	C2	6	C	N3-C2-O2	-5.64	117.95	121.90
31	C1	2069	G	N7-C8-N9	5.63	115.91	113.10
31	C1	770	C	C5-C6-N1	5.63	123.81	121.00
31	C1	787	U	N3-C2-O2	-5.63	118.26	122.20

Continued on next page...

Continued from previous page...

Mol	Chain	Res	Type	Atoms	Z	Observed(°)	Ideal(°)
31	C1	1001	A	P-O3'-C3'	5.62	126.45	119.70
31	C1	2165	U	C5-C6-N1	5.62	125.51	122.70
50	UQ	747	LEU	C-N-CA	5.61	135.73	121.70
62	C2	251	U	N3-C2-O2	-5.61	118.28	122.20
31	C1	60	A	C2-N3-C4	5.60	113.40	110.60
31	C1	2217	C	C6-N1-C2	-5.60	118.06	120.30
31	C1	1656	C	C6-N1-C2	-5.60	118.06	120.30
62	C2	139	C	C6-N1-C2	-5.59	118.06	120.30
31	C1	2217	C	C5-C6-N1	5.59	123.80	121.00
31	C1	683	C	C6-N1-C1'	-5.58	114.10	120.80
62	C2	246	G	N3-C4-C5	-5.58	125.81	128.60
31	C1	1085	U	P-O3'-C3'	5.56	126.37	119.70
62	C2	90	C	O4'-C1'-N1	5.56	112.65	108.20
31	C1	673	C	C6-N1-C2	-5.55	118.08	120.30
62	C2	77	C	C5-C6-N1	5.55	123.77	121.00
31	C1	722	U	N3-C2-O2	-5.52	118.33	122.20
62	C2	246	G	N3-C4-N9	5.52	129.31	126.00
31	C1	1246	C	N3-C2-O2	-5.50	118.05	121.90
31	C1	1068	C	C5-C6-N1	5.50	123.75	121.00
31	C1	1165	U	N1-C2-O2	5.49	126.64	122.80
31	C1	781	G	O4'-C1'-N9	5.48	112.59	108.20
31	C1	26	C	N3-C2-O2	-5.47	118.07	121.90
31	C1	2202	C	C6-N1-C2	-5.47	118.11	120.30
62	C2	200	U	C5-C6-N1	5.47	125.44	122.70
31	C1	2179	C	N3-C2-O2	-5.47	118.07	121.90
31	C1	1241	U	N3-C2-O2	-5.46	118.38	122.20
31	C1	995	C	C2-N1-C1'	5.45	124.80	118.80
31	C1	989	C	N1-C2-O2	5.45	122.17	118.90
31	C1	1165	U	N3-C2-O2	-5.44	118.39	122.20
31	C1	1222	C	C6-N1-C1'	-5.44	114.28	120.80
31	C1	1549	U	C2-N3-C4	-5.43	123.74	127.00
31	C1	1758	C	C6-N1-C1'	5.43	127.31	120.80
31	C1	2174	C	C5-C6-N1	5.42	123.71	121.00
31	C1	661	U	C6-N1-C2	-5.42	117.75	121.00
31	C1	2	G	N3-C4-N9	5.42	129.25	126.00
31	C1	1626	G	C6-N1-C2	-5.41	121.86	125.10
62	C2	136	C	N3-C2-O2	-5.40	118.12	121.90
62	C2	136	C	C6-N1-C2	-5.40	118.14	120.30
31	C1	1120	C	N1-C2-O2	5.40	122.14	118.90
31	C1	915	G	C4-N9-C1'	-5.39	119.49	126.50
31	C1	986	C	N1-C2-O2	5.39	122.14	118.90
31	C1	1256	G	N3-C4-C5	-5.39	125.91	128.60

Continued on next page...

Continued from previous page...

Mol	Chain	Res	Type	Atoms	Z	Observed(°)	Ideal(°)
31	C1	1643	U	C2-N1-C1'	5.38	124.16	117.70
63	Cr	29	LEU	CA-C-N	5.38	132.17	117.10
31	C1	676	C	N3-C2-O2	-5.38	118.14	121.90
31	C1	768	C	C6-N1-C1'	-5.38	114.35	120.80
31	C1	2194	A	N7-C8-N9	5.38	116.49	113.80
62	C2	147	G	N9-C4-C5	-5.37	103.25	105.40
31	C1	683	C	C5-C6-N1	5.36	123.68	121.00
31	C1	851	U	N1-C2-O2	5.36	126.56	122.80
31	C1	1625	G	N3-C2-N2	5.36	123.65	119.90
31	C1	18	G	C2-N3-C4	5.35	114.58	111.90
31	C1	582	G	P-O3'-C3'	5.34	126.11	119.70
31	C1	1761	C	C5-C6-N1	5.34	123.67	121.00
31	C1	879	A	C6-N1-C2	-5.34	115.40	118.60
31	C1	1027	C	C6-N1-C2	-5.34	118.17	120.30
31	C1	2155	G	C4-C5-N7	5.33	112.93	110.80
62	C2	103	G	C4-N9-C1'	5.33	133.43	126.50
62	C2	165	C	N1-C2-O2	5.33	122.10	118.90
33	CV	91	HIS	O-C-N	-5.31	114.20	122.70
31	C1	1471	U	N3-C4-O4	5.31	123.11	119.40
31	C1	2177	G	OP2-P-O3'	5.31	116.88	105.20
31	C1	1045	G	N3-C4-C5	-5.31	125.95	128.60
31	C1	1458	U	N3-C2-O2	-5.30	118.49	122.20
31	C1	1547	C	N3-C4-N4	5.29	121.71	118.00
31	C1	1001	A	OP2-P-O3'	5.29	116.85	105.20
31	C1	1050	U	N3-C2-O2	-5.29	118.50	122.20
31	C1	2219	C	P-O3'-C3'	5.28	126.03	119.70
31	C1	758	U	C2-N3-C4	-5.26	123.84	127.00
31	C1	63	C	C2-N1-C1'	5.24	124.57	118.80
31	C1	645	U	N3-C2-O2	-5.23	118.54	122.20
31	C1	2168	U	C2-N1-C1'	5.23	123.98	117.70
31	C1	1451	G	C8-N9-C1'	-5.23	120.20	127.00
31	C1	1630	C	C6-N1-C1'	5.22	127.07	120.80
21	Ce	38	ALA	C-N-CA	5.22	134.75	121.70
31	C1	1167	C	N1-C2-O2	5.22	122.03	118.90
31	C1	1734	G	P-O3'-C3'	5.21	125.95	119.70
31	C1	43	C	C2-N1-C1'	5.20	124.53	118.80
31	C1	1451	G	C4-C5-N7	5.20	112.88	110.80
31	C1	1625	G	C4-N9-C1'	5.20	133.26	126.50
31	C1	1124	G	C4-N9-C1'	5.20	133.26	126.50
31	C1	435	A	C6-N1-C2	5.19	121.72	118.60
31	C1	2	G	N3-C4-C5	-5.19	126.00	128.60
31	C1	867	C	N1-C2-O2	5.19	122.01	118.90

Continued on next page...

Continued from previous page...

Mol	Chain	Res	Type	Atoms	Z	Observed(°)	Ideal(°)
31	C1	1560	C	C6-N1-C2	-5.19	118.22	120.30
31	C1	1625	G	C6-C5-N7	-5.18	127.29	130.40
31	C1	1658	G	C8-N9-C1'	5.18	133.73	127.00
31	C1	2203	C	N3-C2-O2	-5.18	118.28	121.90
62	C2	79	G	N3-C4-N9	5.18	129.11	126.00
31	C1	2358	U	N1-C2-O2	5.17	126.42	122.80
31	C1	1114	C	C6-N1-C2	-5.17	118.23	120.30
62	C2	202	C	C5-C6-N1	5.17	123.58	121.00
31	C1	582	G	OP1-P-O3'	5.16	116.55	105.20
31	C1	1511	A	C5-C6-N1	5.15	120.28	117.70
31	C1	1646	U	O4'-C1'-N1	5.15	112.32	108.20
31	C1	1068	C	P-O3'-C3'	5.15	125.88	119.70
31	C1	1045	G	N3-C4-N9	5.14	129.09	126.00
31	C1	1245	C	N3-C2-O2	-5.14	118.30	121.90
31	C1	1222	C	C5-C6-N1	5.13	123.57	121.00
31	C1	684	U	N3-C2-O2	-5.13	118.61	122.20
31	C1	768	C	N1-C2-O2	5.13	121.98	118.90
31	C1	1256	G	C4-N9-C1'	5.12	133.16	126.50
31	C1	910	G	N3-C4-N9	-5.12	122.93	126.00
31	C1	1246	C	C6-N1-C1'	5.12	126.94	120.80
31	C1	1662	C	C6-N1-C2	-5.12	118.25	120.30
31	C1	1094	G	C6-C5-N7	-5.12	127.33	130.40
31	C1	2156	A	C4'-C3'-O3'	5.12	123.23	113.00
31	C1	2143	U	C2-N1-C1'	5.11	123.83	117.70
62	C2	161	G	N7-C8-N9	5.11	115.66	113.10
31	C1	1656	C	C5-C6-N1	5.11	123.55	121.00
62	C2	260	G	C2-N3-C4	5.11	114.45	111.90
31	C1	2202	C	C2-N1-C1'	5.11	124.42	118.80
31	C1	859	C	C6-N1-C2	-5.10	118.26	120.30
31	C1	684	U	N1-C2-O2	5.10	126.37	122.80
62	C2	202	C	C6-N1-C2	-5.09	118.26	120.30
31	C1	2227	C	C5-C6-N1	5.08	123.54	121.00
31	C1	63	C	N3-C2-O2	-5.08	118.35	121.90
31	C1	2168	U	C5-C6-N1	5.07	125.24	122.70
31	C1	1075	C	N3-C2-O2	-5.07	118.35	121.90
62	C2	246	G	OP1-P-O3'	5.06	116.34	105.20
31	C1	1081	G	N9-C4-C5	5.06	107.42	105.40
31	C1	1626	G	C8-N9-C4	-5.06	104.38	106.40
31	C1	2086	A	C4-C5-N7	5.06	113.23	110.70
62	C2	166	G	N3-C4-C5	-5.06	126.07	128.60
31	C1	1451	G	C6-C5-N7	-5.06	127.37	130.40
31	C1	2086	A	C5-N7-C8	-5.04	101.38	103.90

Continued on next page...

Continued from previous page...

Mol	Chain	Res	Type	Atoms	Z	Observed(°)	Ideal(°)
31	C1	2229	C	N1-C2-O2	5.04	121.92	118.90
31	C1	727	G	N3-C4-C5	-5.04	126.08	128.60
31	C1	424	U	P-O3'-C3'	5.03	125.74	119.70
31	C1	846	U	N1-C2-O2	5.03	126.32	122.80
31	C1	770	C	N1-C2-O2	5.02	121.91	118.90
31	C1	2172	C	C6-N1-C2	-5.01	118.29	120.30
29	Cq	20	LYS	N-CA-CB	-5.01	101.58	110.60
31	C1	860	C	O4'-C1'-N1	5.00	112.20	108.20
31	C1	909	G	C4-N9-C1'	5.00	133.00	126.50
31	C1	1511	A	N3-C4-N9	5.00	131.40	127.40
50	UQ	472	PRO	C-N-CA	5.00	134.20	121.70

There are no chirality outliers.

All (61) planarity outliers are listed below:

Mol	Chain	Res	Type	Group
56	CB	293	GLU	Peptide
59	CF	60	GLN	Peptide
60	CG	178	VAL	Peptide
35	CH	143	HIS	Peptide
36	CI	851	TRP	Peptide
36	CI	852	ASP	Peptide
13	CK	261	PHE	Peptide
15	CM	140	SER	Peptide
16	CO	84	ILE	Peptide
16	CO	88	ARG	Peptide
18	CQ	173	ASP	Peptide
37	CR	122	MET	Peptide
37	CR	306	GLY	Peptide
37	CR	432	LEU	Peptide
37	CS	122	MET	Peptide
37	CS	306	GLY	Peptide
37	CS	432	LEU	Peptide
33	CV	88	LYS	Peptide
33	CV	92	SER	Mainchain
43	CW	342	SER	Peptide
43	CW	73	GLY	Peptide
38	Cb	231	GLU	Peptide
20	Cc	86	MET	Peptide
21	Ce	38	ALA	Peptide
23	Ch	22	PRO	Peptide
34	Cl	79	TYR	Peptide

Continued on next page...

Continued from previous page...

Mol	Chain	Res	Type	Group
63	Cr	29	LEU	Peptide
1	UA	115	LEU	Peptide
47	UD	387	TRP	Peptide
52	UE	232	GLN	Peptide
48	UJ	1661	ASP	Peptide
48	UJ	1662	GLN	Peptide
6	UL	153	ASP	Peptide
6	UL	636	LEU	Peptide
7	UM	328	LEU	Peptide
7	UM	382	ILE	Peptide
7	UM	445	GLY	Peptide
7	UM	585	HIS	Peptide
49	UO	282	ALA	Peptide
50	UQ	237	TYR	Peptide
50	UQ	426	ALA	Peptide
50	UQ	707	PRO	Peptide
50	UQ	849	ALA	Peptide
9	UR	616	ILE	Peptide
55	US	510	LYS	Peptide
44	UT	1516	LEU	Peptide
44	UT	1566	GLU	Peptide
44	UT	1724	PRO	Peptide
44	UT	408	PRO	Peptide
44	UT	420	GLU	Peptide
44	UT	481	ALA	Peptide
44	UT	485	LYS	Peptide
44	UT	486	GLU	Peptide
44	UT	487	ILE	Peptide
44	UT	781	TRP	Peptide
10	UU	397	ASP	Peptide
10	UU	644	GLY	Peptide
10	UU	857	ILE	Peptide
32	UV	1058	TYR	Peptide
32	UV	1104	LEU	Peptide
32	UV	686	GLY	Peptide

5.2 Too-close contacts [i](#)

Due to software issues we are unable to calculate clashes - this section is therefore empty.

5.3 Torsion angles

5.3.1 Protein backbone

In the following table, the Percentiles column shows the percent Ramachandran outliers of the chain as a percentile score with respect to all PDB entries followed by that with respect to all EM entries.

The Analysed column shows the number of residues for which the backbone conformation was analysed, and the total number of residues.

Mol	Chain	Analysed	Favoured	Allowed	Outliers	Percentiles	
1	UA	835/904 (92%)	768 (92%)	67 (8%)	0	100	100
2	UC	72/648 (11%)	64 (89%)	8 (11%)	0	100	100
3	UF	325/414 (78%)	310 (95%)	14 (4%)	1 (0%)	41	77
4	UG	475/558 (85%)	441 (93%)	32 (7%)	2 (0%)	34	72
5	UK	211/270 (78%)	210 (100%)	1 (0%)	0	100	100
6	UL	767/962 (80%)	711 (93%)	56 (7%)	0	100	100
7	UM	705/912 (77%)	656 (93%)	48 (7%)	1 (0%)	51	86
8	UN	171/938 (18%)	167 (98%)	3 (2%)	1 (1%)	25	66
9	UR	437/618 (71%)	416 (95%)	21 (5%)	0	100	100
10	UU	890/1049 (85%)	833 (94%)	57 (6%)	0	100	100
11	UX	188/193 (97%)	176 (94%)	12 (6%)	0	100	100
12	CJ	177/183 (97%)	166 (94%)	11 (6%)	0	100	100
13	CK	295/297 (99%)	284 (96%)	11 (4%)	0	100	100
14	CL	225/785 (29%)	212 (94%)	12 (5%)	1 (0%)	34	72
15	CM	443/446 (99%)	416 (94%)	27 (6%)	0	100	100
16	CN	222/252 (88%)	210 (95%)	12 (5%)	0	100	100
16	CO	211/252 (84%)	198 (94%)	11 (5%)	2 (1%)	17	57
17	CP	197/322 (61%)	191 (97%)	6 (3%)	0	100	100
18	CQ	171/259 (66%)	164 (96%)	7 (4%)	0	100	100
19	Ca	223/255 (88%)	212 (95%)	11 (5%)	0	100	100
20	Cc	188/212 (89%)	179 (95%)	9 (5%)	0	100	100
21	Ce	155/203 (76%)	139 (90%)	16 (10%)	0	100	100
22	Cg	157/190 (83%)	152 (97%)	5 (3%)	0	100	100
23	Ch	148/151 (98%)	127 (86%)	11 (7%)	10 (7%)	1	15
24	Ci	113/150 (75%)	107 (95%)	6 (5%)	0	100	100

Continued on next page...

Continued from previous page...

Mol	Chain	Analysed	Favoured	Allowed	Outliers	Percentiles	
25	Cj	124/143 (87%)	116 (94%)	8 (6%)	0	100	100
26	Cm	122/130 (94%)	117 (96%)	5 (4%)	0	100	100
27	Cn	92/145 (63%)	89 (97%)	3 (3%)	0	100	100
28	Cp	59/68 (87%)	55 (93%)	4 (7%)	0	100	100
29	Cq	79/82 (96%)	64 (81%)	12 (15%)	3 (4%)	3	24
30	CU	168/311 (54%)	156 (93%)	12 (7%)	0	100	100
32	UV	1057/1171 (90%)	975 (92%)	80 (8%)	2 (0%)	47	81
33	CV	144/322 (45%)	131 (91%)	10 (7%)	3 (2%)	7	36
34	Cl	78/156 (50%)	73 (94%)	5 (6%)	0	100	100
35	CH	383/411 (93%)	346 (90%)	36 (9%)	1 (0%)	41	77
36	CI	812/1163 (70%)	761 (94%)	49 (6%)	2 (0%)	47	81
37	CR	746/1073 (70%)	682 (91%)	60 (8%)	4 (0%)	29	69
37	CS	746/1073 (70%)	682 (91%)	60 (8%)	4 (0%)	29	69
38	Cb	230/264 (87%)	204 (89%)	26 (11%)	0	100	100
39	Cd	224/239 (94%)	211 (94%)	13 (6%)	0	100	100
40	Cf	170/202 (84%)	164 (96%)	6 (4%)	0	100	100
41	Ck	136/161 (84%)	129 (95%)	7 (5%)	0	100	100
42	Co	90/136 (66%)	82 (91%)	8 (9%)	0	100	100
43	CW	380/668 (57%)	349 (92%)	31 (8%)	0	100	100
44	UT	1974/2612 (76%)	1859 (94%)	109 (6%)	6 (0%)	41	77
45	CZ	40/609 (7%)	32 (80%)	8 (20%)	0	100	100
46	UB	496/907 (55%)	464 (94%)	32 (6%)	0	100	100
47	UD	754/884 (85%)	721 (96%)	33 (4%)	0	100	100
48	UJ	1062/1802 (59%)	1010 (95%)	52 (5%)	0	100	100
49	UO	498/557 (89%)	475 (95%)	23 (5%)	0	100	100
50	UQ	775/960 (81%)	712 (92%)	61 (8%)	2 (0%)	41	77
51	CX	265/480 (55%)	255 (96%)	10 (4%)	0	100	100
52	UE	121/410 (30%)	117 (97%)	4 (3%)	0	100	100
52	UI	121/410 (30%)	121 (100%)	0	0	100	100
53	UP	52/364 (14%)	46 (88%)	5 (10%)	1 (2%)	8	38
54	UH	349/930 (38%)	340 (97%)	9 (3%)	0	100	100

Continued on next page...

Continued from previous page...

Mol	Chain	Analysed	Favoured	Allowed	Outliers	Percentiles	
55	US	443/549 (81%)	415 (94%)	28 (6%)	0	100	100
56	CA	238/313 (76%)	225 (94%)	13 (6%)	0	100	100
56	CB	218/313 (70%)	204 (94%)	14 (6%)	0	100	100
57	CC	383/523 (73%)	367 (96%)	16 (4%)	0	100	100
58	CD	416/582 (72%)	393 (94%)	23 (6%)	0	100	100
59	CE	119/127 (94%)	111 (93%)	8 (7%)	0	100	100
59	CF	118/127 (93%)	110 (93%)	7 (6%)	1 (1%)	19	60
60	CG	402/630 (64%)	375 (93%)	27 (7%)	0	100	100
61	CT	127/203 (63%)	119 (94%)	8 (6%)	0	100	100
63	Cr	140/153 (92%)	122 (87%)	13 (9%)	5 (4%)	3	25
All	All	22952/33786 (68%)	21488 (94%)	1412 (6%)	52 (0%)	50	81

All (52) Ramachandran outliers are listed below:

Mol	Chain	Res	Type
16	CO	85	SER
23	Ch	23	PRO
23	Ch	86	GLU
23	Ch	150	VAL
29	Cq	20	LYS
29	Cq	60	THR
29	Cq	62	VAL
32	UV	1059	ASP
33	CV	91	HIS
33	CV	92	SER
44	UT	487	ILE
63	Cr	29	LEU
63	Cr	30	PRO
63	Cr	32	PRO
4	UG	580	GLU
23	Ch	10	GLY
23	Ch	22	PRO
23	Ch	28	THR
33	CV	89	GLN
44	UT	1566	GLU
44	UT	1567	PHE
50	UQ	708	SER
4	UG	56	PRO

Continued on next page...

Continued from previous page...

Mol	Chain	Res	Type
23	Ch	21	ASN
23	Ch	108	ASP
32	UV	612	ARG
37	CR	48	MET
37	CS	48	MET
44	UT	457	TRP
63	Cr	40	THR
8	UN	902	ARG
14	CL	640	PRO
44	UT	407	ILE
44	UT	408	PRO
3	UF	121	LYS
7	UM	329	PRO
23	Ch	85	PRO
23	Ch	138	THR
36	CI	309	PRO
50	UQ	564	GLU
53	UP	329	PRO
37	CR	772	PRO
37	CS	772	PRO
35	CH	258	PRO
37	CR	904	PRO
37	CS	904	PRO
37	CR	404	GLY
37	CS	404	GLY
59	CF	61	PRO
63	Cr	31	VAL
16	CO	84	ILE
36	CI	308	THR

5.3.2 Protein sidechains [i](#)

There are no protein residues with a non-rotameric sidechain to report in this entry.

5.3.3 RNA [i](#)

Mol	Chain	Analysed	Backbone Outliers	Pucker Outliers
31	C1	1197/1859 (64%)	376 (31%)	25 (2%)
62	C2	225/232 (96%)	67 (29%)	4 (1%)
All	All	1422/2091 (68%)	443 (31%)	29 (2%)

All (443) RNA backbone outliers are listed below:

Mol	Chain	Res	Type
31	C1	4	G
31	C1	5	G
31	C1	7	A
31	C1	13	G
31	C1	14	G
31	C1	15	G
31	C1	16	U
31	C1	17	C
31	C1	18	G
31	C1	19	C
31	C1	20	C
31	C1	26	C
31	C1	38	G
31	C1	40	A
31	C1	41	G
31	C1	47	G
31	C1	49	G
31	C1	56	C
31	C1	60	A
31	C1	61	G
31	C1	63	C
31	C1	66	G
31	C1	68	U
31	C1	71	A
31	C1	72	U
31	C1	73	A
31	C1	74	C
31	C1	257	G
31	C1	425	C
31	C1	427	G
31	C1	435	A
31	C1	436	A
31	C1	581	C
31	C1	582	G
31	C1	583	A
31	C1	584	U
31	C1	585	A
31	C1	586	G
31	C1	587	U
31	C1	594	G
31	C1	595	U
31	C1	609	A

Continued on next page...

Continued from previous page...

Mol	Chain	Res	Type
31	C1	610	G
31	C1	613	A
31	C1	614	U
31	C1	621	G
31	C1	624	U
31	C1	628	A
31	C1	638	A
31	C1	646	C
31	C1	650	G
31	C1	652	A
31	C1	653	U
31	C1	655	A
31	C1	656	G
31	C1	659	A
31	C1	660	U
31	C1	661	U
31	C1	662	A
31	C1	663	U
31	C1	664	A
31	C1	667	G
31	C1	678	A
31	C1	679	A
31	C1	680	U
31	C1	682	G
31	C1	683	C
31	C1	685	C
31	C1	686	A
31	C1	687	U
31	C1	688	U
31	C1	689	A
31	C1	690	A
31	C1	692	U
31	C1	693	C
31	C1	697	U
31	C1	700	C
31	C1	702	U
31	C1	703	U
31	C1	711	U
31	C1	713	G
31	C1	714	U
31	C1	715	A
31	C1	718	U

Continued on next page...

Continued from previous page...

Mol	Chain	Res	Type
31	C1	719	U
31	C1	720	A
31	C1	721	C
31	C1	722	U
31	C1	723	A
31	C1	725	A
31	C1	726	U
31	C1	728	G
31	C1	730	U
31	C1	735	G
31	C1	737	G
31	C1	740	A
31	C1	742	U
31	C1	743	U
31	C1	744	C
31	C1	745	U
31	C1	756	C
31	C1	758	U
31	C1	760	C
31	C1	762	G
31	C1	763	A
31	C1	764	A
31	C1	769	C
31	C1	770	C
31	C1	772	A
31	C1	773	C
31	C1	774	U
31	C1	775	U
31	C1	776	C
31	C1	777	G
31	C1	778	G
31	C1	782	G
31	C1	786	G
31	C1	797	A
31	C1	802	A
31	C1	803	A
31	C1	804	A
31	C1	806	C
31	C1	807	A
31	C1	808	A
31	C1	809	U
31	C1	810	G

Continued on next page...

Continued from previous page...

Mol	Chain	Res	Type
31	C1	811	C
31	C1	816	C
31	C1	828	G
31	C1	833	U
31	C1	834	C
31	C1	841	A
31	C1	845	C
31	C1	849	A
31	C1	850	A
31	C1	851	U
31	C1	856	C
31	C1	858	G
31	C1	860	C
31	C1	861	U
31	C1	862	U
31	C1	863	G
31	C1	886	U
31	C1	889	C
31	C1	892	C
31	C1	893	C
31	C1	897	U
31	C1	900	A
31	C1	903	U
31	C1	907	A
31	C1	913	G
31	C1	921	G
31	C1	922	C
31	C1	925	G
31	C1	927	C
31	C1	929	U
31	C1	930	G
31	C1	934	A
31	C1	935	C
31	C1	936	A
31	C1	942	U
31	C1	943	A
31	C1	944	A
31	C1	971	A
31	C1	972	A
31	C1	984	A
31	C1	985	A
31	C1	986	C

Continued on next page...

Continued from previous page...

Mol	Chain	Res	Type
31	C1	987	G
31	C1	988	G
31	C1	989	C
31	C1	1000	A
31	C1	1001	A
31	C1	1002	G
31	C1	1005	A
31	C1	1007	G
31	C1	1017	C
31	C1	1018	G
31	C1	1021	A
31	C1	1022	A
31	C1	1023	U
31	C1	1024	U
31	C1	1025	A
31	C1	1027	C
31	C1	1028	C
31	C1	1029	A
31	C1	1035	G
31	C1	1036	A
31	C1	1037	C
31	C1	1039	C
31	C1	1043	G
31	C1	1044	A
31	C1	1054	A
31	C1	1059	A
31	C1	1061	A
31	C1	1064	G
31	C1	1069	A
31	C1	1070	G
31	C1	1076	U
31	C1	1077	U
31	C1	1078	U
31	C1	1079	C
31	C1	1080	G
31	C1	1085	U
31	C1	1086	U
31	C1	1088	U
31	C1	1089	A
31	C1	1094	G
31	C1	1095	A
31	C1	1099	A

Continued on next page...

Continued from previous page...

Mol	Chain	Res	Type
31	C1	1102	A
31	C1	1103	C
31	C1	1104	A
31	C1	1116	U
31	C1	1120	C
31	C1	1122	A
31	C1	1123	G
31	C1	1124	G
31	C1	1125	A
31	C1	1126	A
31	C1	1127	C
31	C1	1128	A
31	C1	1129	A
31	C1	1141	G
31	C1	1147	U
31	C1	1148	G
31	C1	1150	C
31	C1	1154	A
31	C1	1158	G
31	C1	1163	A
31	C1	1164	A
31	C1	1166	U
31	C1	1167	C
31	C1	1168	C
31	C1	1169	A
31	C1	1170	G
31	C1	1178	A
31	C1	1179	G
31	C1	1186	U
31	C1	1218	G
31	C1	1219	A
31	C1	1220	A
31	C1	1222	C
31	C1	1223	U
31	C1	1251	C
31	C1	1258	A
31	C1	1265	G
31	C1	1444	A
31	C1	1447	A
31	C1	1448	A
31	C1	1449	U
31	C1	1450	A

Continued on next page...

Continued from previous page...

Mol	Chain	Res	Type
31	C1	1451	G
31	C1	1452	G
31	C1	1469	A
31	C1	1470	G
31	C1	1471	U
31	C1	1479	U
31	C1	1481	U
31	C1	1483	A
31	C1	1484	G
31	C1	1486	G
31	C1	1489	G
31	C1	1491	A
31	C1	1497	U
31	C1	1498	G
31	C1	1499	G
31	C1	1517	A
31	C1	1518	A
31	C1	1519	C
31	C1	1520	U
31	C1	1525	A
31	C1	1527	G
31	C1	1529	A
31	C1	1536	A
31	C1	1545	U
31	C1	1549	U
31	C1	1551	A
31	C1	1554	C
31	C1	1555	A
31	C1	1614	U
31	C1	1624	A
31	C1	1625	G
31	C1	1628	A
31	C1	1632	G
31	C1	1636	G
31	C1	1637	C
31	C1	1639	U
31	C1	1642	A
31	C1	1643	U
31	C1	1644	U
31	C1	1645	U
31	C1	1656	C
31	C1	1659	C

Continued on next page...

Continued from previous page...

Mol	Chain	Res	Type
31	C1	1665	A
31	C1	1667	G
31	C1	1668	A
31	C1	1670	A
31	C1	1698	G
31	C1	1701	U
31	C1	1709	A
31	C1	1711	G
31	C1	1712	C
31	C1	1713	U
31	C1	1735	A
31	C1	1738	G
31	C1	1742	C
31	C1	1743	C
31	C1	1744	A
31	C1	1751	G
31	C1	2045	G
31	C1	2052	A
31	C1	2054	A
31	C1	2056	U
31	C1	2057	G
31	C1	2061	G
31	C1	2065	C
31	C1	2069	G
31	C1	2070	A
31	C1	2072	U
31	C1	2073	A
31	C1	2074	C
31	C1	2075	U
31	C1	2076	C
31	C1	2089	G
31	C1	2097	U
31	C1	2099	A
31	C1	2100	U
31	C1	2104	G
31	C1	2106	U
31	C1	2107	A
31	C1	2118	U
31	C1	2119	G
31	C1	2120	C
31	C1	2121	U
31	C1	2123	G

Continued on next page...

Continued from previous page...

Mol	Chain	Res	Type
31	C1	2140	U
31	C1	2142	A
31	C1	2156	A
31	C1	2157	G
31	C1	2158	G
31	C1	2166	A
31	C1	2167	G
31	C1	2173	G
31	C1	2177	G
31	C1	2178	U
31	C1	2183	A
31	C1	2184	G
31	C1	2185	C
31	C1	2190	G
31	C1	2197	A
31	C1	2201	C
31	C1	2202	C
31	C1	2210	U
31	C1	2211	U
31	C1	2212	G
31	C1	2213	U
31	C1	2214	A
31	C1	2215	C
31	C1	2216	A
31	C1	2220	C
31	C1	2222	C
31	C1	2223	C
31	C1	2227	C
31	C1	2238	A
31	C1	2328	G
31	C1	2329	A
31	C1	2330	G
31	C1	2351	G
31	C1	2362	U
31	C1	2363	G
31	C1	2364	A
31	C1	2365	A
31	C1	2366	C
31	C1	2373	A
31	C1	2374	G
62	C2	5	A
62	C2	8	A

Continued on next page...

Continued from previous page...

Mol	Chain	Res	Type
62	C2	15	A
62	C2	23	A
62	C2	24	U
62	C2	28	U
62	C2	29	A
62	C2	33	U
62	C2	36	U
62	C2	37	U
62	C2	39	U
62	C2	48	G
62	C2	57	A
62	C2	58	A
62	C2	62	A
62	C2	63	G
62	C2	81	G
62	C2	90	C
62	C2	91	G
62	C2	92	A
62	C2	95	U
62	C2	100	G
62	C2	104	C
62	C2	111	G
62	C2	118	C
62	C2	125	U
62	C2	126	U
62	C2	127	A
62	C2	128	C
62	C2	135	U
62	C2	136	C
62	C2	140	C
62	C2	142	G
62	C2	145	A
62	C2	147	G
62	C2	148	G
62	C2	153	G
62	C2	160	U
62	C2	162	C
62	C2	163	C
62	C2	164	U
62	C2	165	C
62	C2	166	G
62	C2	167	U

Continued on next page...

Continued from previous page...

Mol	Chain	Res	Type
62	C2	168	C
62	C2	170	C
62	C2	178	U
62	C2	179	A
62	C2	181	A
62	C2	182	G
62	C2	187	U
62	C2	188	G
62	C2	189	G
62	C2	190	C
62	C2	198	U
62	C2	199	G
62	C2	200	U
62	C2	201	A
62	C2	205	C
62	C2	244	G
62	C2	247	G
62	C2	255	U
62	C2	256	G
62	C2	259	A
62	C2	260	G
62	C2	261	U
62	C2	262	C

All (29) RNA pucker outliers are listed below:

Mol	Chain	Res	Type
31	C1	424	U
31	C1	582	G
31	C1	593	G
31	C1	684	U
31	C1	771	G
31	C1	802	A
31	C1	906	G
31	C1	1001	A
31	C1	1017	C
31	C1	1068	C
31	C1	1077	U
31	C1	1085	U
31	C1	1087	G
31	C1	1163	A
31	C1	1264	U

Continued on next page...

Continued from previous page...

Mol	Chain	Res	Type
31	C1	1485	A
31	C1	1638	G
31	C1	1712	C
31	C1	1734	G
31	C1	2064	C
31	C1	2072	U
31	C1	2156	A
31	C1	2157	G
31	C1	2177	G
31	C1	2219	C
62	C2	23	A
62	C2	35	G
62	C2	91	G
62	C2	255	U

5.4 Non-standard residues in protein, DNA, RNA chains [i](#)

There are no non-standard protein/DNA/RNA residues in this entry.

5.5 Carbohydrates [i](#)

There are no monosaccharides in this entry.

5.6 Ligand geometry [i](#)

Of 2 ligands modelled in this entry, 2 are monoatomic - leaving 0 for Mogul analysis.

There are no bond length outliers.

There are no bond angle outliers.

There are no chirality outliers.

There are no torsion outliers.

There are no ring outliers.

No monomer is involved in short contacts.

5.7 Other polymers [i](#)

There are no such residues in this entry.

5.8 Polymer linkage issues

The following chains have linkage breaks:

Mol	Chain	Number of breaks
31	C1	4
62	C2	2

All chain breaks are listed below:

Model	Chain	Residue-1	Atom-1	Residue-2	Atom-2	Distance (Å)
1	C1	74:C	O3'	244:G	P	56.87
1	C1	257:G	O3'	417:G	P	43.92
1	C2	206:G	O3'	240:C	P	18.77
1	C2	105:C	O3'	110:A	P	16.05
1	C1	34:C	O3'	36:C	P	5.49
1	C1	53:A	O3'	55:G	P	4.34

6 Map visualisation [i](#)

This section contains visualisations of the EMDB entry EMD-10054. These allow visual inspection of the internal detail of the map and identification of artifacts.

No raw map or half-maps were deposited for this entry and therefore no images, graphs, etc. pertaining to the raw map can be shown.

6.1 Orthogonal projections [i](#)

6.1.1 Primary map

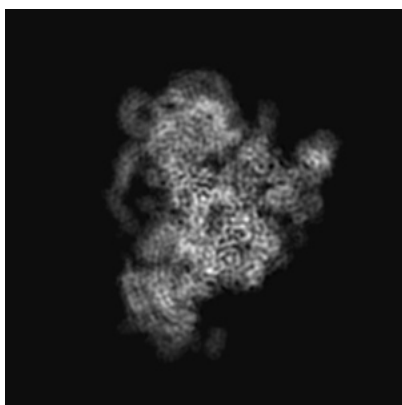

X

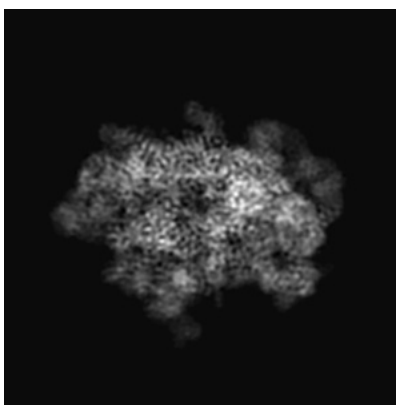

Y

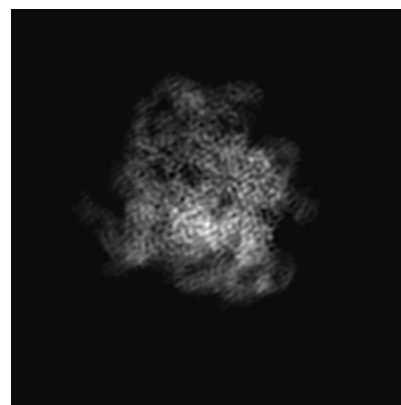

Z

The images above show the map projected in three orthogonal directions.

6.2 Central slices [i](#)

6.2.1 Primary map

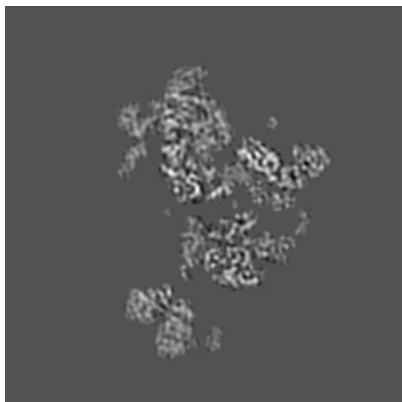

X Index: 240

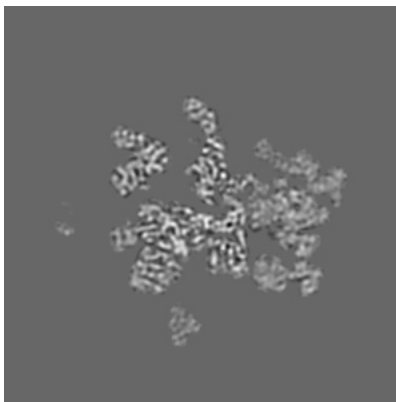

Y Index: 240

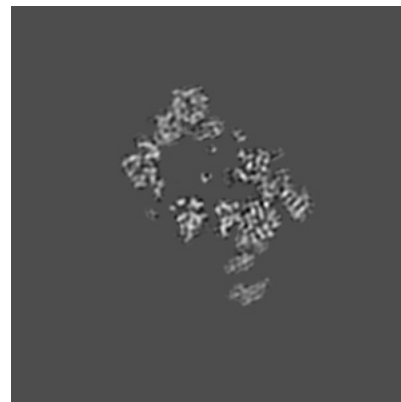

Z Index: 240

The images above show central slices of the map in three orthogonal directions.

6.3 Largest variance slices [i](#)

6.3.1 Primary map

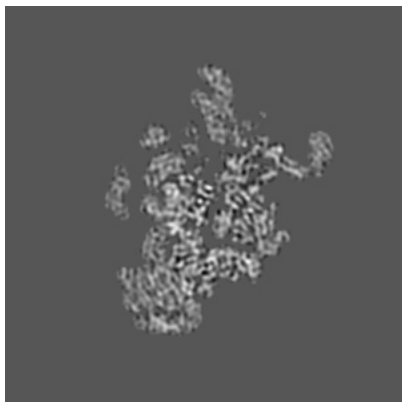

X Index: 279

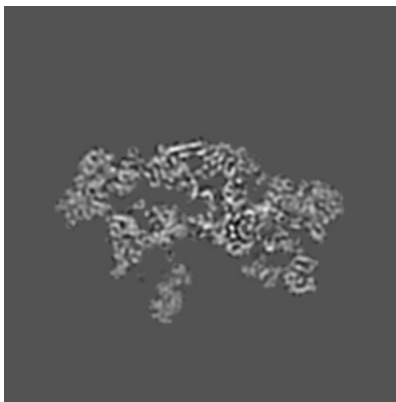

Y Index: 213



Z Index: 247

The images above show the largest variance slices of the map in three orthogonal directions.

6.4 Orthogonal surface views [i](#)

6.4.1 Primary map



X

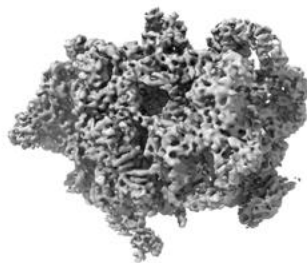

Y

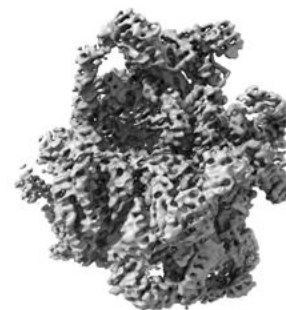

Z

The images above show the 3D surface view of the map at the recommended contour level 0.03. These images, in conjunction with the slice images, may facilitate assessment of whether an appropriate contour level has been provided.

6.5 Mask visualisation

This section was not generated. No masks/segmentation were deposited.

7 Map analysis [i](#)

This section contains the results of statistical analysis of the map.

7.1 Map-value distribution [i](#)

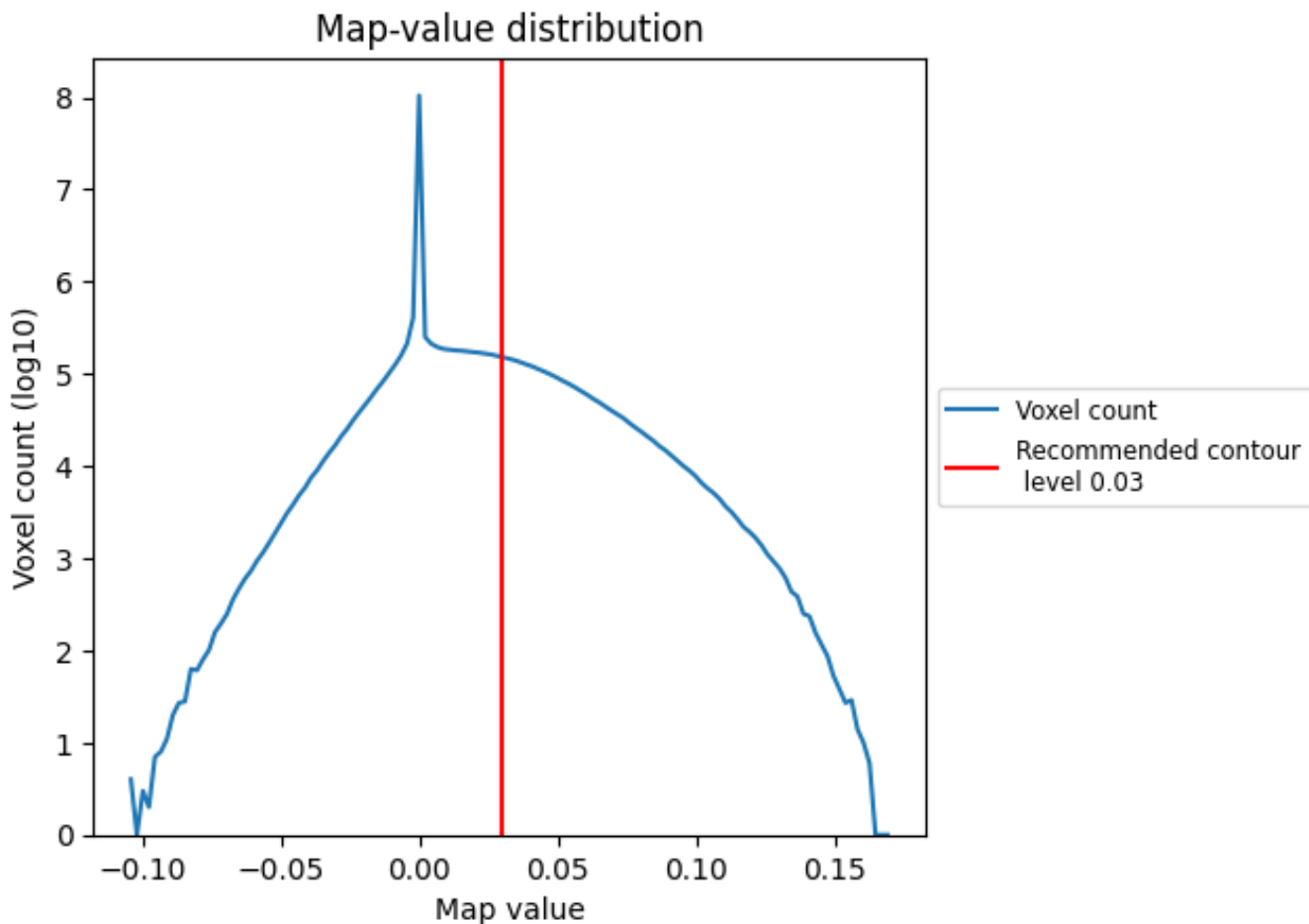

The map-value distribution is plotted in 128 intervals along the x-axis. The y-axis is logarithmic. A spike in this graph at zero usually indicates that the volume has been masked.

7.2 Volume estimate [i](#)

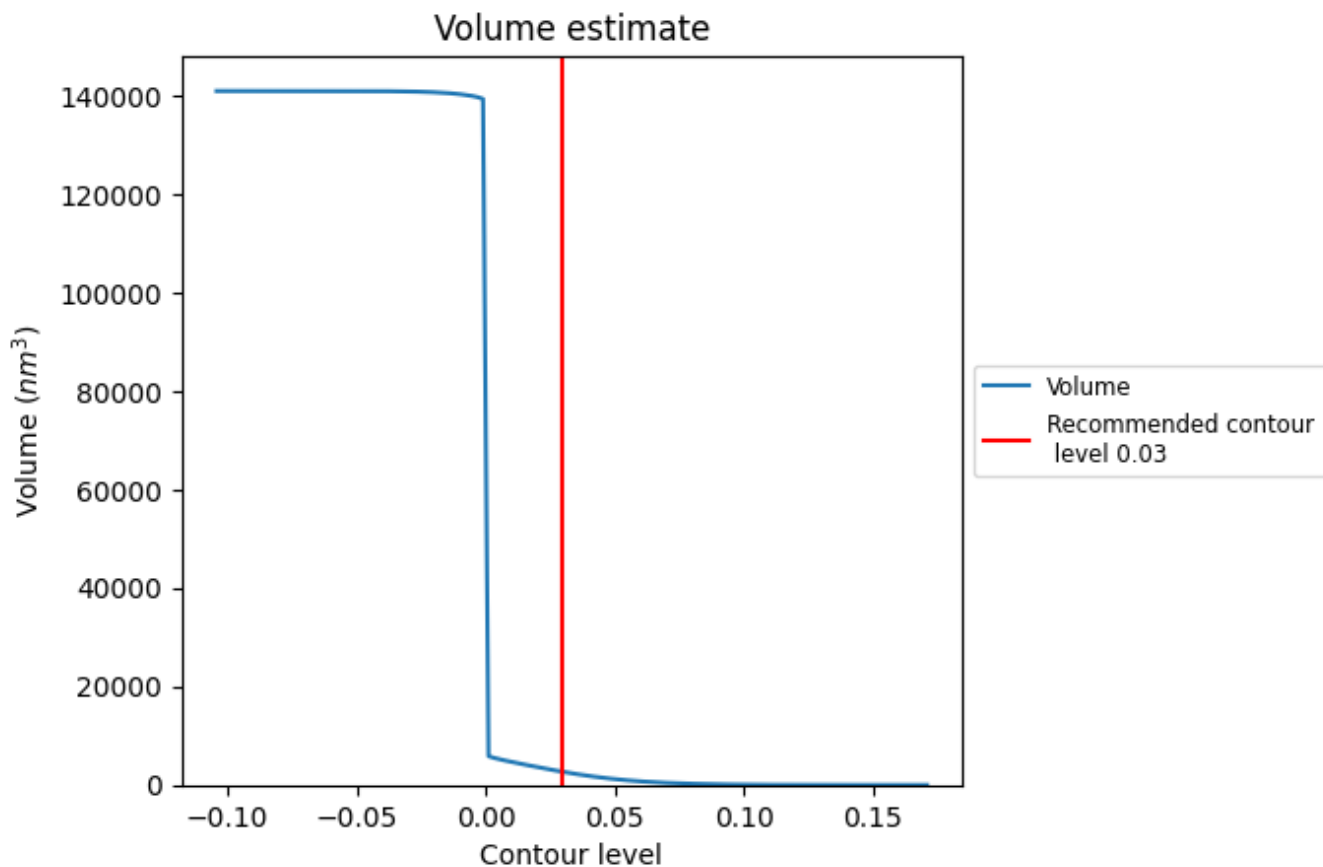

The volume at the recommended contour level is 2664 nm³; this corresponds to an approximate mass of 2407 kDa.

The volume estimate graph shows how the enclosed volume varies with the contour level. The recommended contour level is shown as a vertical line and the intersection between the line and the curve gives the volume of the enclosed surface at the given level.

7.3 Rotationally averaged power spectrum [i](#)

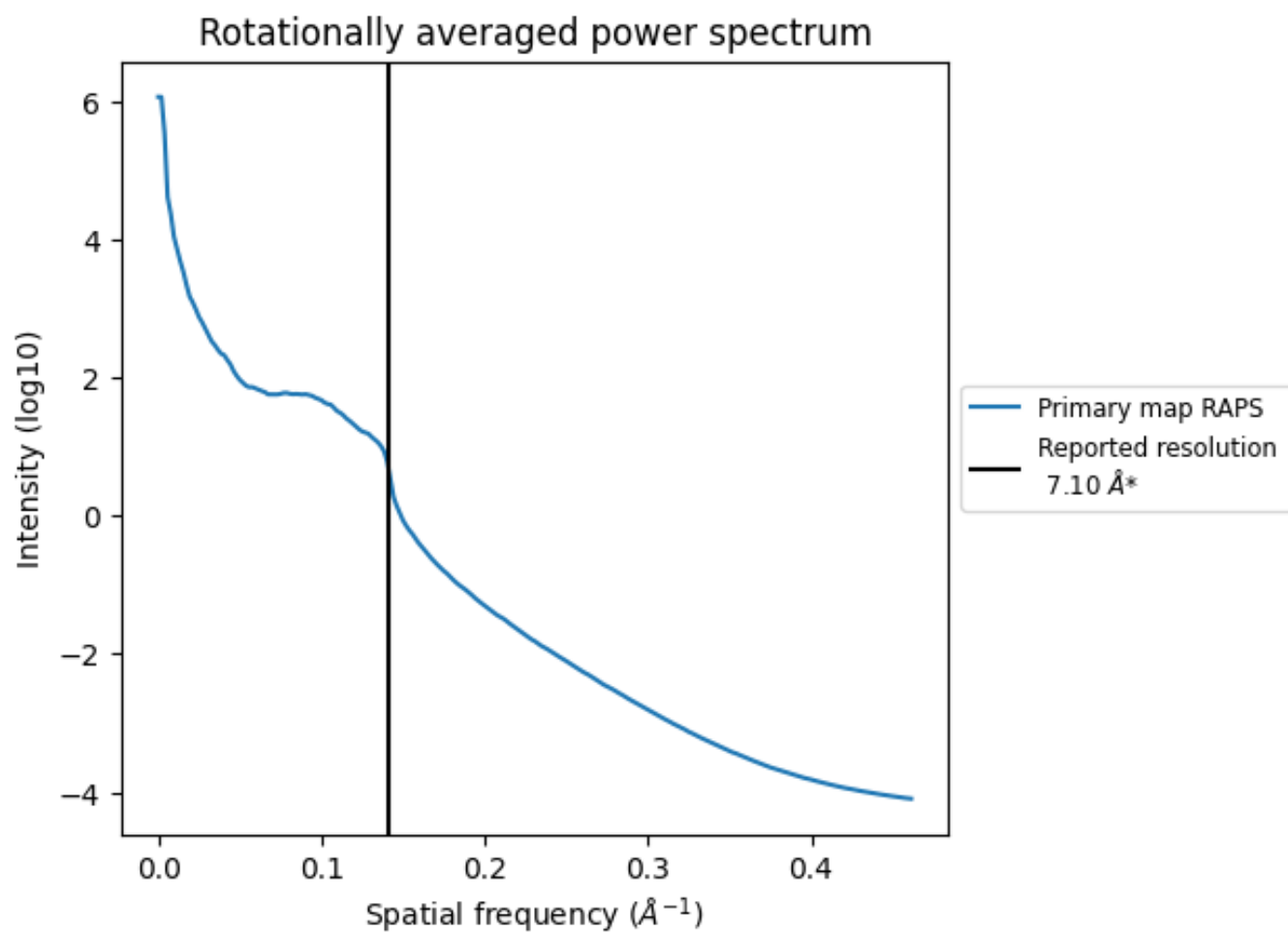

*Reported resolution corresponds to spatial frequency of 0.141\AA^{-1}

8 Fourier-Shell correlation [i](#)

Fourier-Shell Correlation (FSC) is the most commonly used method to estimate the resolution of single-particle and subtomogram-averaged maps. The shape of the curve depends on the imposed symmetry, mask and whether or not the two 3D reconstructions used were processed from a common reference. The reported resolution is shown as a black line. A curve is displayed for the half-bit criterion in addition to lines showing the 0.143 gold standard cut-off and 0.5 cut-off.

8.1 FSC [i](#)

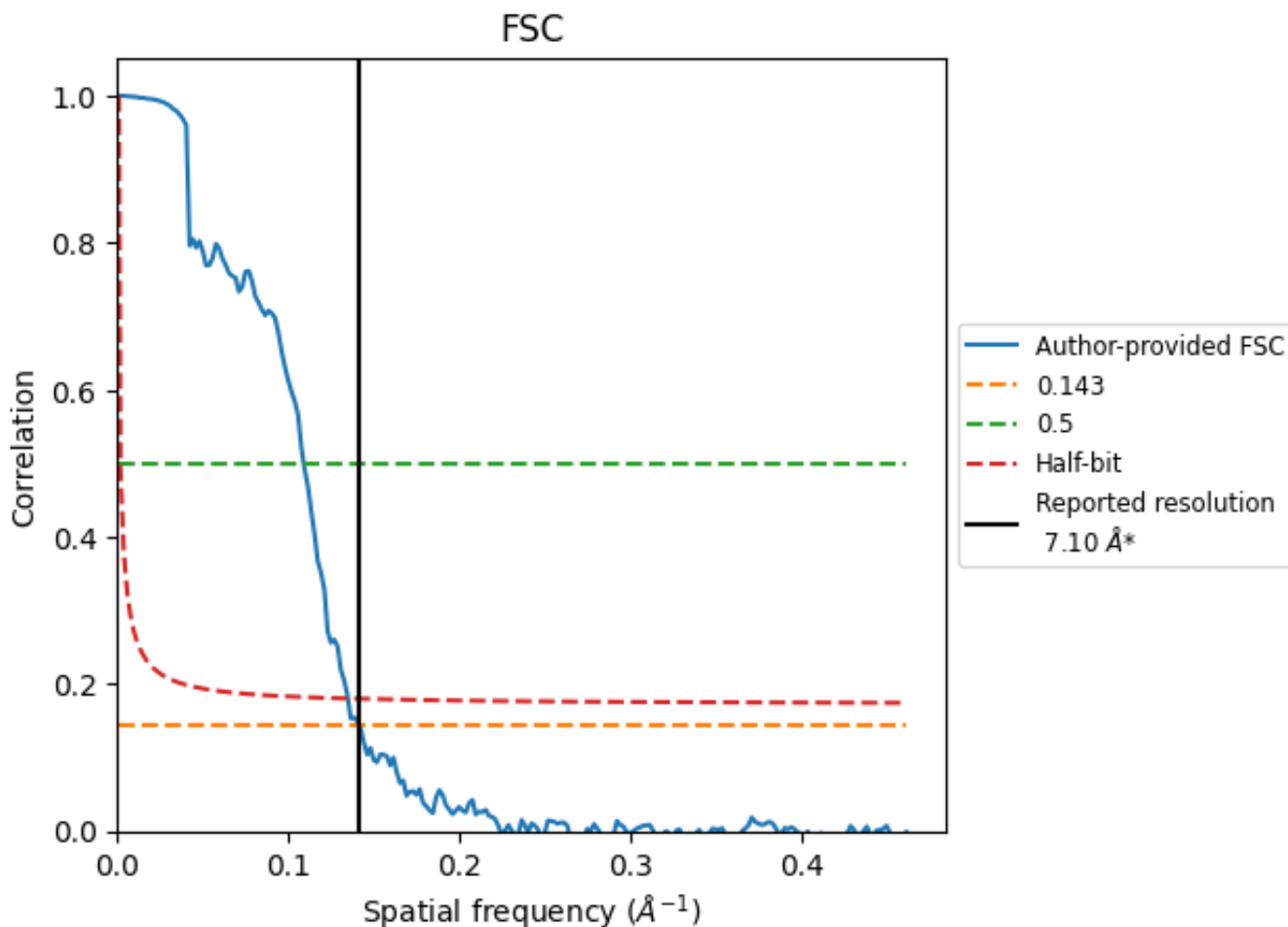

*Reported resolution corresponds to spatial frequency of 0.141 Å⁻¹

8.2 Resolution estimates [i](#)

Resolution estimate (Å)	Estimation criterion (FSC cut-off)		
	0.143	0.5	Half-bit
Reported by author	7.10	-	-
Author-provided FSC curve	7.07	9.17	7.42
Unmasked-calculated*	-	-	-

*Resolution estimate based on FSC curve calculated by comparison of deposited half-maps.

9 Map-model fit [i](#)

This section contains information regarding the fit between EMDB map EMD-10054 and PDB model 6RXX. Per-residue inclusion information can be found in section 3 on page 16.

9.1 Map-model overlay [i](#)

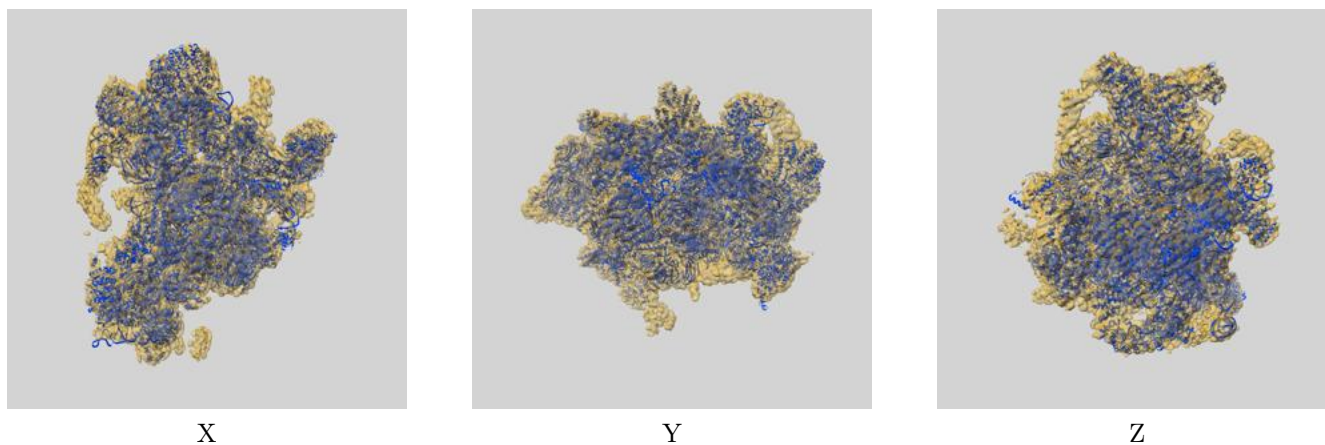

The images above show the 3D surface view of the map at the recommended contour level 0.03 at 50% transparency in yellow overlaid with a ribbon representation of the model coloured in blue. These images allow for the visual assessment of the quality of fit between the atomic model and the map.

9.2 Q-score mapped to coordinate model [i](#)

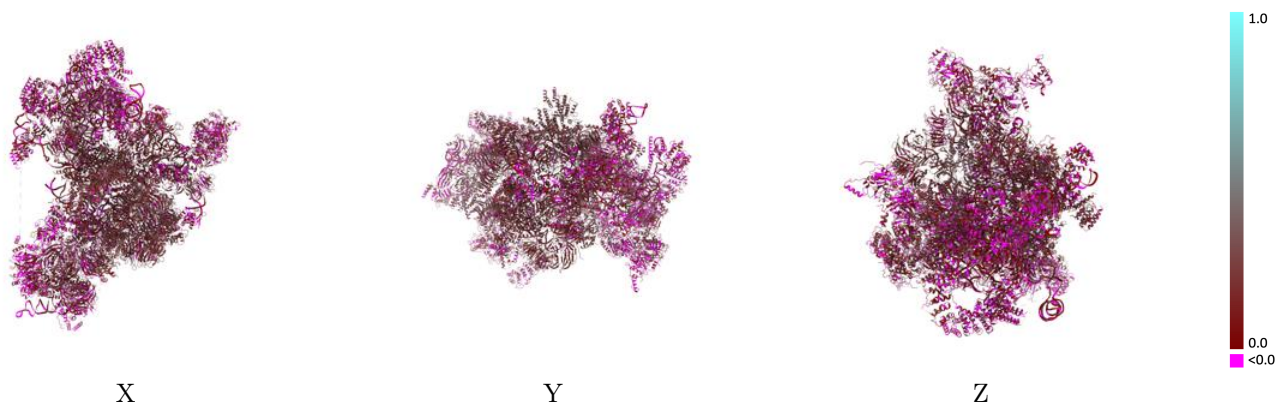

The images above show the model with each residue coloured according to its Q-score. This shows their resolvability in the map with higher Q-score values reflecting better resolvability. Please note: Q-score is calculating the resolvability of atoms, and thus high values are only expected at resolutions at which atoms can be resolved. Low Q-score values may therefore be expected for many entries.

9.3 Atom inclusion mapped to coordinate model [i](#)

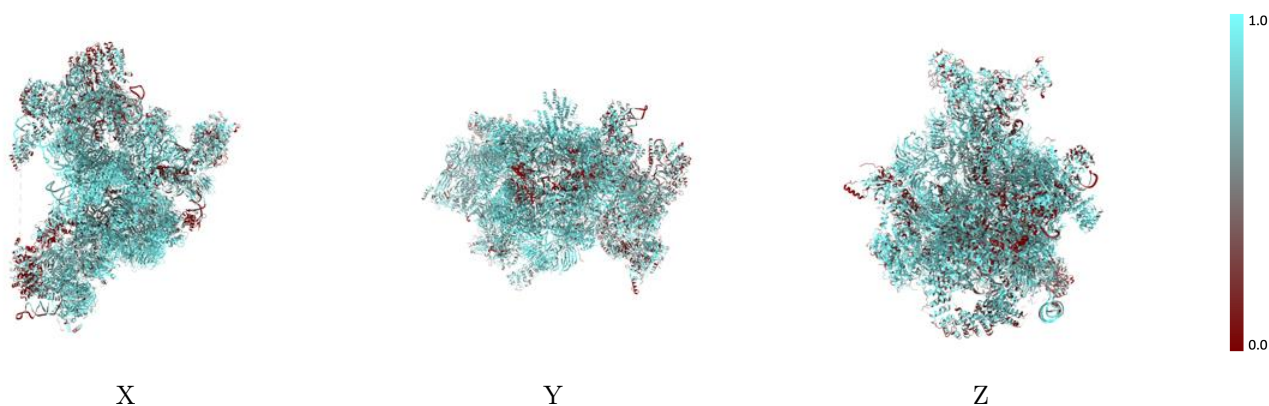

The images above show the model with each residue coloured according to its atom inclusion. This shows to what extent they are inside the map at the recommended contour level (0.03).



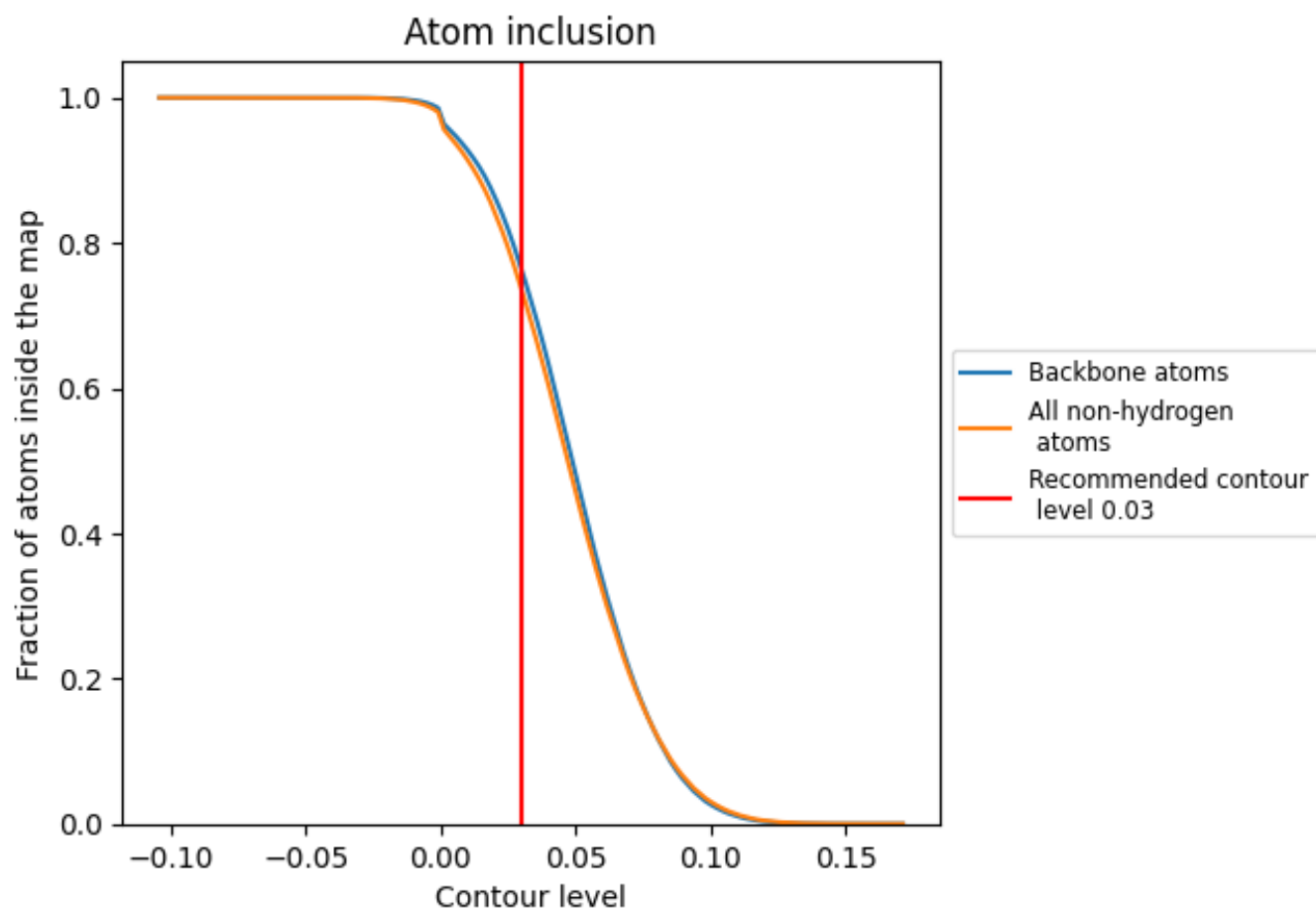



































































9.4 Atom inclusion [i](#)



At the recommended contour level, 76% of all backbone atoms, 73% of all non-hydrogen atoms, are inside the map.

9.5 Map-model fit summary





































































The table lists the average atom inclusion at the recommended contour level (0.03) and Q-score for the entire model and for each chain.

Chain	Atom inclusion	Q-score
All	 0.7343	 0.1560
C1	 0.7617	 0.1390
C2	 0.7891	 0.1470
CA	 0.8520	 0.2410
CB	 0.4954	 0.0480
CC	 0.8760	 0.2410
CD	 0.6946	 0.1650
CE	 0.6755	 0.1340
CF	 0.8020	 0.1880
CG	 0.7789	 0.1600
CH	 0.8764	 0.2290
CI	 0.8594	 0.2360
CJ	 0.7888	 0.2200
CK	 0.7636	 0.2260
CL	 0.7443	 0.2110
CM	 0.8642	 0.2390
CN	 0.6791	 0.1520
CO	 0.5951	 0.0800
CP	 0.5045	 0.1520
CQ	 0.2072	 0.0590
CR	 0.7824	 0.1690
CS	 0.5923	 0.0780
CT	 0.8068	 0.2310
CU	 0.1676	 0.0390
CV	 0.5902	 0.0810
CW	 0.6394	 0.1150
CX	 0.6181	 0.0520
CZ	 0.7343	 0.1480
Ca	 0.7749	 0.1940
Cb	 0.5737	 0.0950
Cc	 0.8583	 0.2280
Cd	 0.7428	 0.1650
Ce	 0.7354	 0.1770
Cf	 0.6350	 0.0500
Cg	 0.8204	 0.2110



Continued on next page...

Continued from previous page...

Chain	Atom inclusion	Q-score
Ch	 0.8124	 0.2250
Ci	 0.7265	 0.1540
Cj	 0.7830	 0.2250
Ck	 0.4703	 0.0310
Cl	 0.4709	 0.0900
Cm	 0.8129	 0.2230
Cn	 0.8380	 0.2450
Co	 0.9029	 0.2100
Cp	 0.8467	 0.2140
Cq	 0.7805	 0.1910
Cr	 0.6657	 0.1870
UA	 0.8426	 0.2220
UB	 0.7493	 0.1500
UC	 0.8864	 0.2630
UD	 0.7278	 0.1210
UE	 0.8474	 0.2050
UF	 0.9039	 0.2370
UG	 0.7476	 0.1850
UH	 0.7470	 0.1370
UI	 0.6883	 0.1450
UJ	 0.6259	 0.1430
UK	 0.5093	 0.1030
UL	 0.8875	 0.2260
UM	 0.8170	 0.1760
UN	 0.8011	 0.2300
UO	 0.8258	 0.2060
UP	 0.6075	 0.1550
UQ	 0.8179	 0.1600
UR	 0.7853	 0.1700
US	 0.6641	 0.1290
UT	 0.6005	 0.0860
UU	 0.8603	 0.2110
UV	 0.5873	 0.0900
UX	 0.6628	 0.1970