



wwPDB X-ray Structure Validation Summary Report ⓘ

Oct 4, 2023 – 03:33 AM EDT

PDB ID : 6P67
Title : Crystal Structure of a Complex of human IL-7Ralpha with an anti-IL-7Ralpha 2B8 Fab
Authors : Walsh, S.T.R.; Kashi, L.; Kohnhorst, C.L.
Deposited on : 2019-06-03
Resolution : 2.90 Å(reported)

This is a wwPDB X-ray Structure Validation Summary Report for a publicly released PDB entry.

We welcome your comments at validation@mail.wwpdb.org

A user guide is available at

<https://www.wwpdb.org/validation/2017/XrayValidationReportHelp>

with specific help available everywhere you see the ⓘ symbol.

The types of validation reports are described at

<http://www.wwpdb.org/validation/2017/FAQs#types>.

The following versions of software and data (see [references ⓘ](#)) were used in the production of this report:

MolProbity : 4.02b-467
Mogul : 1.8.5 (274361), CSD as541be (2020)
Xtriage (Phenix) : 1.13
EDS : 2.35.1
Percentile statistics : 20191225.v01 (using entries in the PDB archive December 25th 2019)
Refmac : 5.8.0158
CCP4 : 7.0.044 (Gargrove)
Ideal geometry (proteins) : Engh & Huber (2001)
Ideal geometry (DNA, RNA) : Parkinson et al. (1996)
Validation Pipeline (wwPDB-VP) : 2.35.1

1 Overall quality at a glance

The following experimental techniques were used to determine the structure:

X-RAY DIFFRACTION

The reported resolution of this entry is 2.90 Å.

Percentile scores (ranging between 0-100) for global validation metrics of the entry are shown in the following graphic. The table shows the number of entries on which the scores are based.

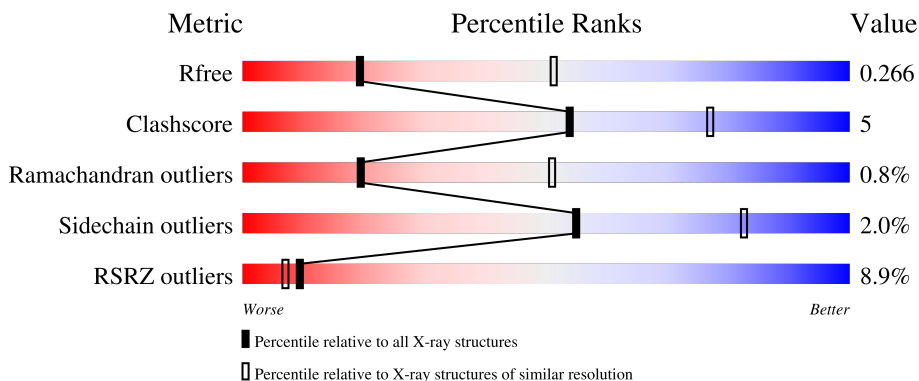







Metric	Whole archive (#Entries)	Similar resolution (#Entries, resolution range(Å))
R_{free}	130704	1957 (2.90-2.90)
Clashscore	141614	2172 (2.90-2.90)
Ramachandran outliers	138981	2115 (2.90-2.90)
Sidechain outliers	138945	2117 (2.90-2.90)
RSRZ outliers	127900	1906 (2.90-2.90)

The table below summarises the geometric issues observed across the polymeric chains and their fit to the electron density. The red, orange, yellow and green segments of the lower bar indicate the fraction of residues that contain outliers for ≥ 3 , 2, 1 and 0 types of geometric quality criteria respectively. A grey segment represents the fraction of residues that are not modelled. The numeric value for each fraction is indicated below the corresponding segment, with a dot representing fractions $\leq 5\%$. The upper red bar (where present) indicates the fraction of residues that have poor fit to the electron density. The numeric value is given above the bar.

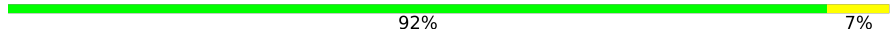
Mol	Chain	Length	Quality of chain
1	A	225	 4% 89% 8% ..
1	C	225	 5% 92% 7% .
1	E	225	 4% 84% 13% ..
1	H	225	 4% 85% 13% ..
2	B	214	 92% 7%

Continued on next page...

Continued from previous page...

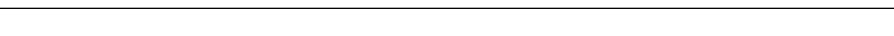
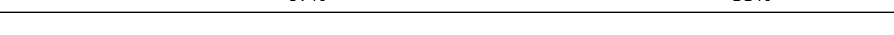
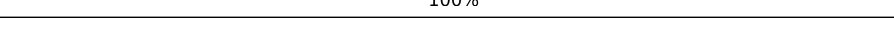
Mol	Chain	Length	Quality of chain
2	D	214	 92% 7%
2	F	214	 85% 14%
2	L	214	 87% 12%
3	G	223	 8% 70% 17% 13%
3	I	223	 20% 64% 22% 13%
3	J	223	 25% 78% 9% 13%
3	K	223	 30% 74% 9% 16%
4	M	3	 67% 33%
4	N	3	 100%
5	O	2	 100%

The following table lists non-polymeric compounds, carbohydrate monomers and non-standard residues in protein, DNA, RNA chains that are outliers for geometric or electron-density-fit criteria:

Mol	Type	Chain	Res	Chirality	Geometry	Clashes	Electron density
4	NAG	N	2	-	-	-	X
7	NAG	I	301	-	-	-	X

2 Entry composition [i](#)

There are 7 unique types of molecules in this entry. The entry contains 19325 atoms, of which 0 are hydrogens and 0 are deuteriums.

In the tables below, the ZeroOcc column contains the number of atoms modelled with zero occupancy, the AltConf column contains the number of residues with at least one atom in alternate conformation and the Trace column contains the number of residues modelled with at most 2 atoms.

- Molecule 1 is a protein called Anti-IL-7R 2B8 Fab heavy chain.

Mol	Chain	Residues	Atoms					ZeroOcc	AltConf	Trace
			Total	C	N	O	S			
1	A	223	Total 1664	C 1053	N 267	O 336	S 8	0	0	0
1	C	223	Total 1667	C 1055	N 266	O 338	S 8	0	0	0
1	E	220	Total 1637	C 1040	N 261	O 328	S 8	0	0	0
1	H	223	Total 1677	C 1062	N 271	O 336	S 8	0	0	0

- Molecule 2 is a protein called anti-IL-7R 2B8 Fab light chain.

Mol	Chain	Residues	Atoms					ZeroOcc	AltConf	Trace
			Total	C	N	O	S			
2	B	213	Total 1652	C 1037	N 277	O 332	S 6	0	0	0
2	D	213	Total 1652	C 1037	N 277	O 332	S 6	0	0	0
2	F	213	Total 1648	C 1035	N 277	O 330	S 6	0	0	0
2	L	213	Total 1652	C 1037	N 277	O 332	S 6	0	0	0

- Molecule 3 is a protein called Interleukin-7 receptor subunit alpha.

Mol	Chain	Residues	Atoms					ZeroOcc	AltConf	Trace
			Total	C	N	O	S			
3	G	195	Total 1558	C 1008	N 252	O 290	S 8	0	0	0
3	I	193	Total 1542	C 997	N 250	O 287	S 8	0	0	0
3	J	195	Total 1420	C 908	N 235	O 269	S 8	0	0	0
3	K	188	Total 1384	C 886	N 232	O 258	S 8	0	0	0

There are 20 discrepancies between the modelled and reference sequences:

Chain	Residue	Modelled	Actual	Comment	Reference
G	-3	GLY	-	expression tag	UNP P16871
G	-2	SER	-	expression tag	UNP P16871
G	-1	HIS	-	expression tag	UNP P16871
G	0	MET	-	expression tag	UNP P16871
G	46	THR	ILE	conflict	UNP P16871
I	-3	GLY	-	expression tag	UNP P16871
I	-2	SER	-	expression tag	UNP P16871
I	-1	HIS	-	expression tag	UNP P16871
I	0	MET	-	expression tag	UNP P16871
I	46	THR	ILE	conflict	UNP P16871
J	-3	GLY	-	expression tag	UNP P16871
J	-2	SER	-	expression tag	UNP P16871
J	-1	HIS	-	expression tag	UNP P16871
J	0	MET	-	expression tag	UNP P16871
J	46	THR	ILE	conflict	UNP P16871
K	-3	GLY	-	expression tag	UNP P16871
K	-2	SER	-	expression tag	UNP P16871
K	-1	HIS	-	expression tag	UNP P16871
K	0	MET	-	expression tag	UNP P16871
K	46	THR	ILE	conflict	UNP P16871

- Molecule 4 is an oligosaccharide called beta-D-mannopyranose-(1-4)-2-acetamido-2-deoxy-beta-D-glucopyranose-(1-4)-2-acetamido-2-deoxy-beta-D-glucopyranose.

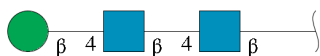

Mol	Chain	Residues	Atoms				ZeroOcc	AltConf	Trace
			Total	C	N	O			
4	M	3	39	22	2	15	0	0	0
4	N	3	39	22	2	15	0	0	0

- Molecule 5 is an oligosaccharide called 2-acetamido-2-deoxy-beta-D-glucopyranose-(1-4)-2-acetamido-2-deoxy-beta-D-glucopyranose.



Mol	Chain	Residues	Atoms				ZeroOcc	AltConf	Trace
			Total	C	N	O			
5	O	2	28	16	2	10	0	0	0

- Molecule 6 is alpha-L-fucopyranose (three-letter code: FUC) (formula: C₆H₁₂O₅).

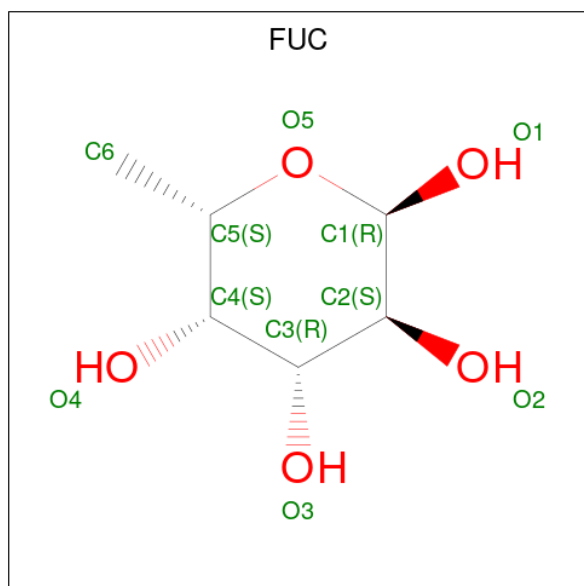

Mol	Chain	Residues	Atoms			ZeroOcc	AltConf
			Total	C	O		
6	G	1	10	6	4	0	0

- Molecule 7 is 2-acetamido-2-deoxy-beta-D-glucopyranose (three-letter code: NAG) (formula: C₈H₁₅NO₆).

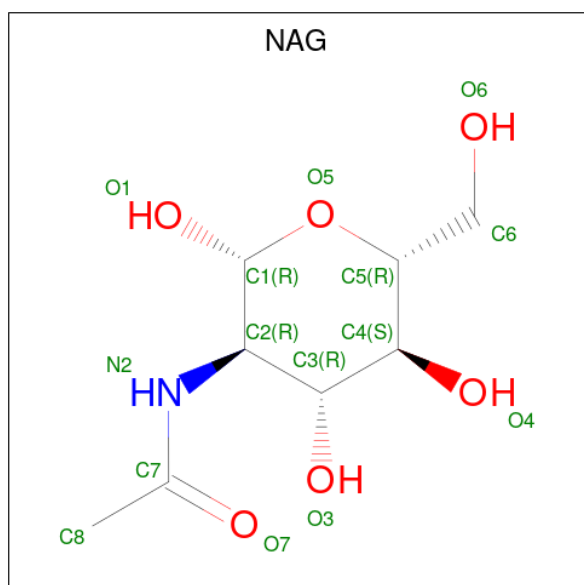

Mol	Chain	Residues	Atoms				ZeroOcc	AltConf
7	G	1	Total 14	C 8	N 1	O 5	0	0
7	I	1	Total 14	C 8	N 1	O 5	0	0
7	J	1	Total 14	C 8	N 1	O 5	0	0
7	K	1	Total 14	C 8	N 1	O 5	0	0

3 Residue-property plots [i](#)

These plots are drawn for all protein, RNA, DNA and oligosaccharide chains in the entry. The first graphic for a chain summarises the proportions of the various outlier classes displayed in the second graphic. The second graphic shows the sequence view annotated by issues in geometry and electron density. Residues are color-coded according to the number of geometric quality criteria for which they contain at least one outlier: green = 0, yellow = 1, orange = 2 and red = 3 or more. A red dot above a residue indicates a poor fit to the electron density ($RSRZ > 2$). Stretches of 2 or more consecutive residues without any outlier are shown as a green connector. Residues present in the sample, but not in the model, are shown in grey.

- Molecule 1: Anti-IL-7R 2B8 Fab heavy chain

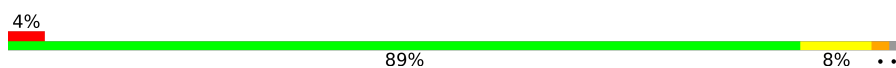
Chain A: 

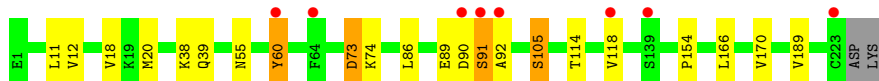

- Molecule 1: Anti-IL-7R 2B8 Fab heavy chain

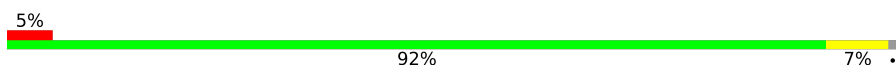
Chain C: 



- Molecule 1: Anti-IL-7R 2B8 Fab heavy chain

Chain E: 



- Molecule 1: Anti-IL-7R 2B8 Fab heavy chain

Chain H: 

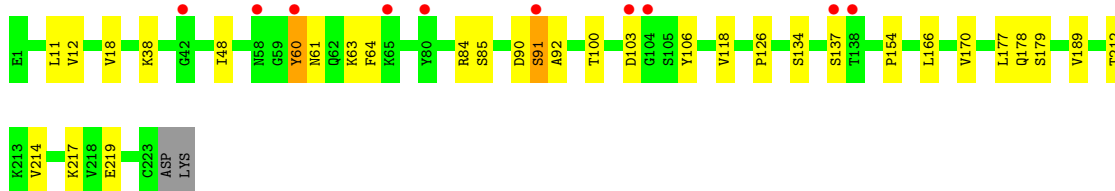

- Molecule 2: anti-IL-7R 2B8 Fab light chain

Chain B:  92% 7%



- Molecule 2: anti-IL-7R 2B8 Fab light chain

Chain D:  92% 7%



- Molecule 2: anti-IL-7R 2B8 Fab light chain

Chain F:  85% 14%

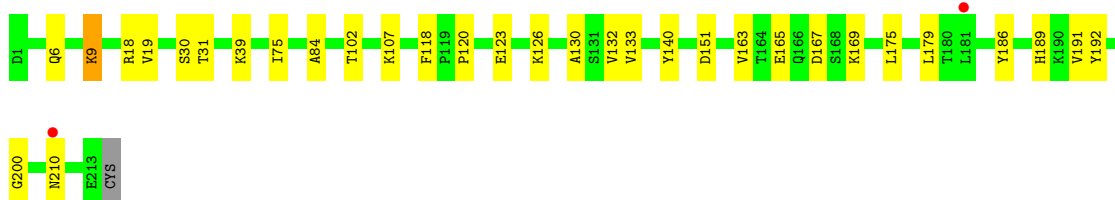

- Molecule 2: anti-IL-7R 2B8 Fab light chain

Chain L:  87% 12%



- Molecule 3: Interleukin-7 receptor subunit alpha

Chain G:  70% 17% 8% 13%

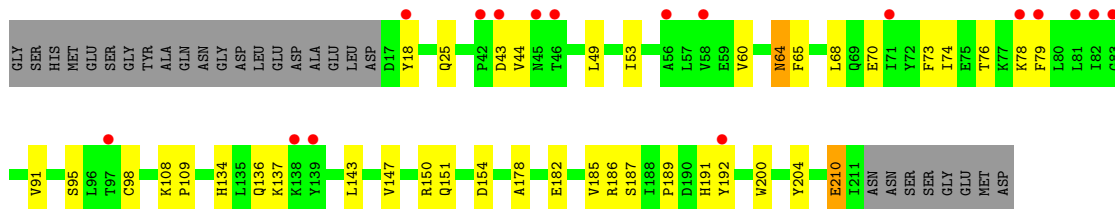

- Molecule 3: Interleukin-7 receptor subunit alpha

Chain I:  64% 22% 13%

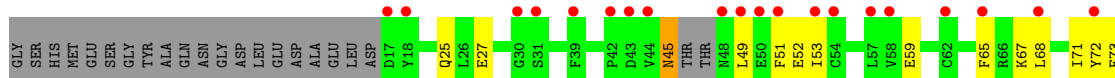

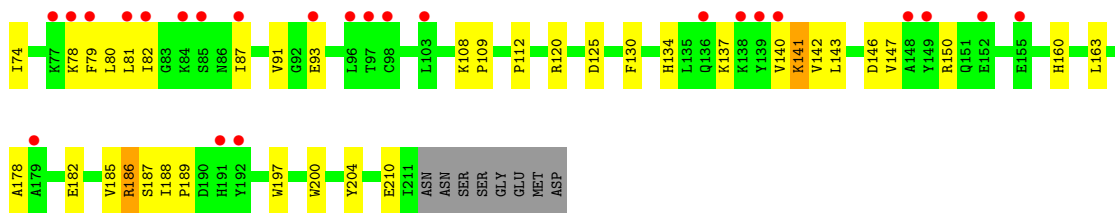

- Molecule 3: Interleukin-7 receptor subunit alpha

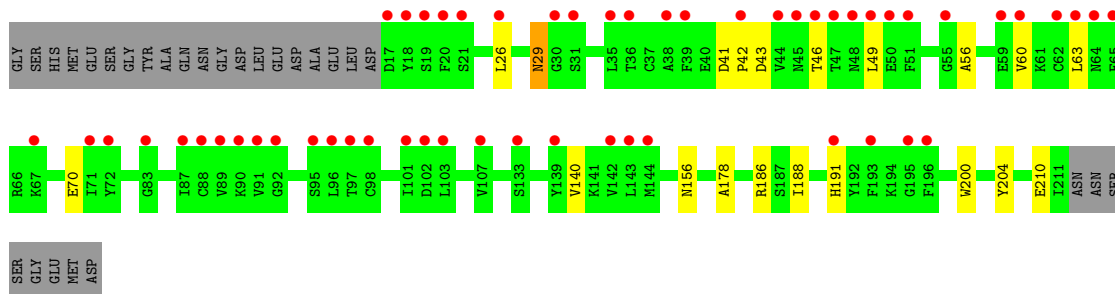
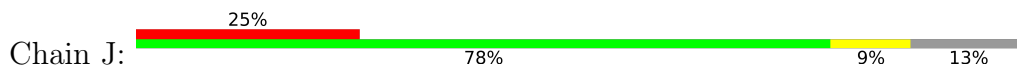

- Molecule 3: Interleukin-7 receptor subunit alpha

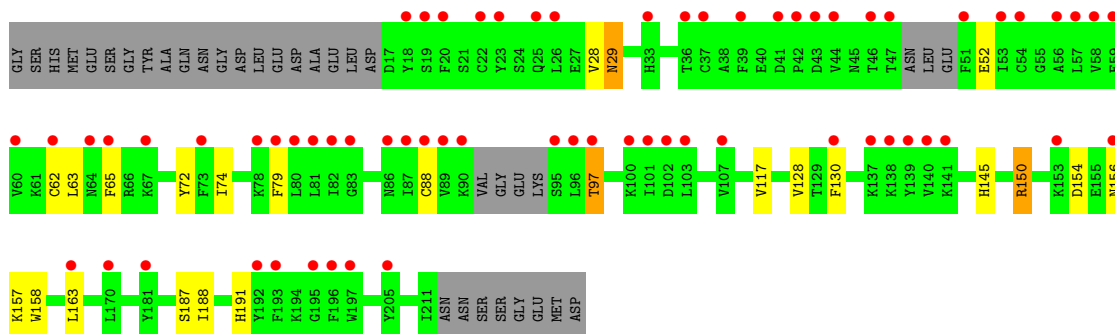
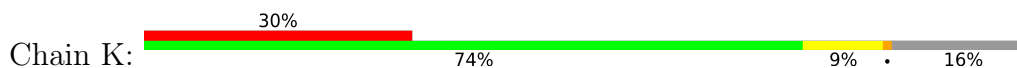

- Molecule 4: beta-D-mannopyranose-(1-4)-2-acetamido-2-deoxy-beta-D-glucopyranose-(1-4)-2-acetamido-2-deoxy-beta-D-glucopyranose



- Molecule 4: beta-D-mannopyranose-(1-4)-2-acetamido-2-deoxy-beta-D-glucopyranose-(1-4)-2-acetamido-2-deoxy-beta-D-glucopyranose



- Molecule 5: 2-acetamido-2-deoxy-beta-D-glucopyranose-(1-4)-2-acetamido-2-deoxy-beta-D-glucopyranose

Chain O:  100%

MAGE
MAGZ

4 Data and refinement statistics

Property	Value	Source
Space group	P 1 21 1	Depositor
Cell constants a, b, c, α , β , γ	84.90Å 219.68Å 90.35Å 90.00° 104.33° 90.00°	Depositor
Resolution (Å)	43.77 – 2.90 43.77 – 2.90	Depositor EDS
% Data completeness (in resolution range)	99.2 (43.77-2.90) 99.3 (43.77-2.90)	Depositor EDS
R_{merge}	(Not available)	Depositor
R_{sym}	(Not available)	Depositor
$\langle I/\sigma(I) \rangle$ ¹	1.46 (at 2.90Å)	Xtrriage
Refinement program	phenix.refine 1.16rc1_3535, PHENIX 1.16rc1_3535	Depositor
R, R_{free}	0.249 , 0.266 0.248 , 0.266	Depositor DCC
R_{free} test set	1986 reflections (2.83%)	wwPDB-VP
Wilson B-factor (Å ²)	73.1	Xtrriage
Anisotropy	0.588	Xtrriage
Bulk solvent k_{sol} (e/Å ³), B_{sol} (Å ²)	0.28 , 46.6	EDS
L-test for twinning ²	$\langle L \rangle = 0.50$, $\langle L^2 \rangle = 0.33$	Xtrriage
Estimated twinning fraction	No twinning to report.	Xtrriage
F_o, F_c correlation	0.92	EDS
Total number of atoms	19325	wwPDB-VP
Average B, all atoms (Å ²)	90.0	wwPDB-VP

Xtrriage's analysis on translational NCS is as follows: *The largest off-origin peak in the Patterson function is 4.47% of the height of the origin peak. No significant pseudotranslation is detected.*

¹Intensities estimated from amplitudes.

²Theoretical values of $\langle |L| \rangle$, $\langle L^2 \rangle$ for acentric reflections are 0.5, 0.333 respectively for untwinned datasets, and 0.375, 0.2 for perfectly twinned datasets.

5 Model quality [i](#)

5.1 Standard geometry [i](#)

Bond lengths and bond angles in the following residue types are not validated in this section: NAG, BMA, FUC

The Z score for a bond length (or angle) is the number of standard deviations the observed value is removed from the expected value. A bond length (or angle) with $|Z| > 5$ is considered an outlier worth inspection. RMSZ is the root-mean-square of all Z scores of the bond lengths (or angles).

Mol	Chain	Bond lengths		Bond angles	
		RMSZ	# Z >5	RMSZ	# Z >5
1	A	0.26	0/1708	0.50	0/2329
1	C	0.26	0/1712	0.50	0/2335
1	E	0.25	0/1681	0.48	0/2292
1	H	0.26	0/1722	0.51	0/2345
2	B	0.26	0/1688	0.49	0/2290
2	D	0.26	0/1688	0.49	0/2290
2	F	0.31	0/1684	0.53	1/2285 (0.0%)
2	L	0.26	0/1688	0.48	0/2290
3	G	0.27	0/1597	0.50	0/2171
3	I	0.31	0/1580	0.52	1/2142 (0.0%)
3	J	0.25	0/1457	0.48	0/1999
3	K	0.26	0/1419	0.48	0/1942
All	All	0.27	0/19624	0.50	2/26710 (0.0%)

There are no bond length outliers.

All (2) bond angle outliers are listed below:

Mol	Chain	Res	Type	Atoms	Z	Observed(°)	Ideal(°)
2	F	18	ARG	NE-CZ-NH1	-7.89	116.36	120.30
3	I	186	ARG	CD-NE-CZ	5.29	131.00	123.60

There are no chirality outliers.

There are no planarity outliers.

5.2 Too-close contacts [i](#)

In the following table, the Non-H and H(model) columns list the number of non-hydrogen atoms and hydrogen atoms in the chain respectively. The H(added) column lists the number of hydrogen

atoms added and optimized by MolProbity. The Clashes column lists the number of clashes within the asymmetric unit, whereas Symm-Clashes lists symmetry-related clashes.

Mol	Chain	Non-H	H(model)	H(added)	Clashes	Symm-Clashes
1	A	1664	0	1580	15	0
1	C	1667	0	1578	7	0
1	E	1637	0	1546	15	1
1	H	1677	0	1607	21	2
2	B	1652	0	1606	14	0
2	D	1652	0	1606	12	0
2	F	1648	0	1602	24	0
2	L	1652	0	1606	18	0
3	G	1558	0	1489	25	1
3	I	1542	0	1472	41	1
3	J	1420	0	1200	8	0
3	K	1384	0	1184	13	0
4	M	39	0	34	2	0
4	N	39	0	34	0	0
5	O	28	0	25	0	0
6	G	10	0	10	0	0
7	G	14	0	13	0	0
7	I	14	0	13	0	1
7	J	14	0	13	0	0
7	K	14	0	13	1	0
All	All	19325	0	18231	199	3

The all-atom clashscore is defined as the number of clashes found per 1000 atoms (including hydrogen atoms). The all-atom clashscore for this structure is 5.

The worst 5 of 199 close contacts within the same asymmetric unit are listed below, sorted by their clash magnitude.

Atom-1	Atom-2	Interatomic distance (Å)	Clash overlap (Å)
2:L:9:LYS:HD3	2:L:9:LYS:H	1.39	0.86
1:H:90:ASP:O	1:H:92:ALA:N	2.16	0.79
3:I:178:ALA:HB2	3:I:210:GLU:HG2	1.65	0.77
2:F:9:LYS:H	2:F:9:LYS:HD3	1.51	0.76
2:B:9:LYS:H	2:B:9:LYS:HD3	1.50	0.75

All (3) symmetry-related close contacts are listed below. The label for Atom-2 includes the symmetry operator and encoded unit-cell translations to be applied.

Atom-1	Atom-2	Interatomic distance (Å)	Clash overlap (Å)
1:H:179:SER:O	7:I:301:NAG:O4[2_646]	1.99	0.21
1:E:103:ASP:OD2	3:I:204:TYR:OH[1_554]	2.00	0.20
3:G:204:TYR:OH	1:H:103:ASP:OD2[1_554]	2.13	0.07

5.3 Torsion angles [i](#)

5.3.1 Protein backbone [i](#)

In the following table, the Percentiles column shows the percent Ramachandran outliers of the chain as a percentile score with respect to all X-ray entries followed by that with respect to entries of similar resolution.

The Analysed column shows the number of residues for which the backbone conformation was analysed, and the total number of residues.

Mol	Chain	Analysed	Favoured	Allowed	Outliers	Percentiles	
1	A	221/225 (98%)	210 (95%)	8 (4%)	3 (1%)	11	36
1	C	221/225 (98%)	208 (94%)	10 (4%)	3 (1%)	11	36
1	E	216/225 (96%)	201 (93%)	12 (6%)	3 (1%)	11	36
1	H	221/225 (98%)	208 (94%)	11 (5%)	2 (1%)	17	48
2	B	211/214 (99%)	205 (97%)	6 (3%)	0	100	100
2	D	211/214 (99%)	205 (97%)	6 (3%)	0	100	100
2	F	211/214 (99%)	204 (97%)	7 (3%)	0	100	100
2	L	211/214 (99%)	203 (96%)	6 (3%)	2 (1%)	17	48
3	G	193/223 (86%)	175 (91%)	16 (8%)	2 (1%)	15	45
3	I	189/223 (85%)	172 (91%)	16 (8%)	1 (0%)	29	61
3	J	193/223 (86%)	173 (90%)	18 (9%)	2 (1%)	15	45
3	K	182/223 (82%)	168 (92%)	12 (7%)	2 (1%)	14	42
All	All	2480/2648 (94%)	2332 (94%)	128 (5%)	20 (1%)	19	51

5 of 20 Ramachandran outliers are listed below:

Mol	Chain	Res	Type
1	A	60	TYR
1	C	60	TYR
1	E	91	SER
1	H	84	ARG
1	H	91	SER

5.3.2 Protein sidechains [i](#)

In the following table, the Percentiles column shows the percent sidechain outliers of the chain as a percentile score with respect to all X-ray entries followed by that with respect to entries of similar resolution.

The Analysed column shows the number of residues for which the sidechain conformation was analysed, and the total number of residues.

Mol	Chain	Analysed	Rotameric	Outliers	Percentiles	
1	A	185/193 (96%)	182 (98%)	3 (2%)	62	86
1	C	186/193 (96%)	182 (98%)	4 (2%)	52	81
1	E	180/193 (93%)	176 (98%)	4 (2%)	52	81
1	H	188/193 (97%)	186 (99%)	2 (1%)	73	92
2	B	188/189 (100%)	186 (99%)	2 (1%)	73	92
2	D	188/189 (100%)	188 (100%)	0	100	100
2	F	187/189 (99%)	184 (98%)	3 (2%)	62	86
2	L	188/189 (100%)	186 (99%)	2 (1%)	73	92
3	G	170/204 (83%)	168 (99%)	2 (1%)	71	91
3	I	168/204 (82%)	161 (96%)	7 (4%)	30	63
3	J	132/204 (65%)	127 (96%)	5 (4%)	33	67
3	K	131/204 (64%)	123 (94%)	8 (6%)	18	48
All	All	2091/2344 (89%)	2049 (98%)	42 (2%)	55	82

5 of 42 residues with a non-rotameric sidechain are listed below:

Mol	Chain	Res	Type
3	J	43	ASP
3	K	97	THR
3	J	70	GLU
3	K	29	ASN
3	K	154	ASP

Sometimes sidechains can be flipped to improve hydrogen bonding and reduce clashes. All (2) such sidechains are listed below:

Mol	Chain	Res	Type
3	G	136	GLN
3	I	160	HIS

5.3.3 RNA [i](#)

There are no RNA molecules in this entry.

5.4 Non-standard residues in protein, DNA, RNA chains [i](#)

There are no non-standard protein/DNA/RNA residues in this entry.

5.5 Carbohydrates [i](#)

8 monosaccharides are modelled in this entry.

In the following table, the Counts columns list the number of bonds (or angles) for which Mogul statistics could be retrieved, the number of bonds (or angles) that are observed in the model and the number of bonds (or angles) that are defined in the Chemical Component Dictionary. The Link column lists molecule types, if any, to which the group is linked. The Z score for a bond length (or angle) is the number of standard deviations the observed value is removed from the expected value. A bond length (or angle) with $|Z| > 2$ is considered an outlier worth inspection. RMSZ is the root-mean-square of all Z scores of the bond lengths (or angles).

Mol	Type	Chain	Res	Link	Bond lengths			Bond angles		
					Counts	RMSZ	# Z > 2	Counts	RMSZ	# Z > 2
4	NAG	M	1	3,4	14,14,15	0.29	0	17,19,21	0.50	0
4	NAG	M	2	4	14,14,15	0.42	0	17,19,21	0.40	0
4	BMA	M	3	4	11,11,12	0.63	0	15,15,17	0.75	0
4	NAG	N	1	3,4	14,14,15	0.22	0	17,19,21	0.46	0
4	NAG	N	2	4	14,14,15	0.26	0	17,19,21	0.49	0
4	BMA	N	3	4	11,11,12	0.47	0	15,15,17	0.85	0
5	NAG	O	1	3,5	14,14,15	0.23	0	17,19,21	0.41	0
5	NAG	O	2	5	14,14,15	0.29	0	17,19,21	0.41	0

In the following table, the Chirals column lists the number of chiral outliers, the number of chiral centers analysed, the number of these observed in the model and the number defined in the Chemical Component Dictionary. Similar counts are reported in the Torsion and Rings columns. '-' means no outliers of that kind were identified.

Mol	Type	Chain	Res	Link	Chirals	Torsions	Rings
4	NAG	M	1	3,4	-	2/6/23/26	0/1/1/1
4	NAG	M	2	4	-	0/6/23/26	0/1/1/1
4	BMA	M	3	4	-	0/2/19/22	0/1/1/1
4	NAG	N	1	3,4	-	2/6/23/26	0/1/1/1
4	NAG	N	2	4	-	1/6/23/26	0/1/1/1
4	BMA	N	3	4	-	1/2/19/22	0/1/1/1

Continued on next page...

Continued from previous page...

Mol	Type	Chain	Res	Link	Chirals	Torsions	Rings
5	NAG	O	1	3,5	-	0/6/23/26	0/1/1/1
5	NAG	O	2	5	-	0/6/23/26	0/1/1/1

There are no bond length outliers.

There are no bond angle outliers.

There are no chirality outliers.

5 of 6 torsion outliers are listed below:

Mol	Chain	Res	Type	Atoms
4	N	1	NAG	O5-C5-C6-O6
4	N	1	NAG	C4-C5-C6-O6
4	N	3	BMA	O5-C5-C6-O6
4	N	2	NAG	C3-C2-N2-C7
4	M	1	NAG	C4-C5-C6-O6

There are no ring outliers.

1 monomer is involved in 2 short contacts:

Mol	Chain	Res	Type	Clashes	Symm-Clashes
4	M	1	NAG	2	0

The following is a two-dimensional graphical depiction of Mogul quality analysis of bond lengths, bond angles, torsion angles, and ring geometry for oligosaccharide.

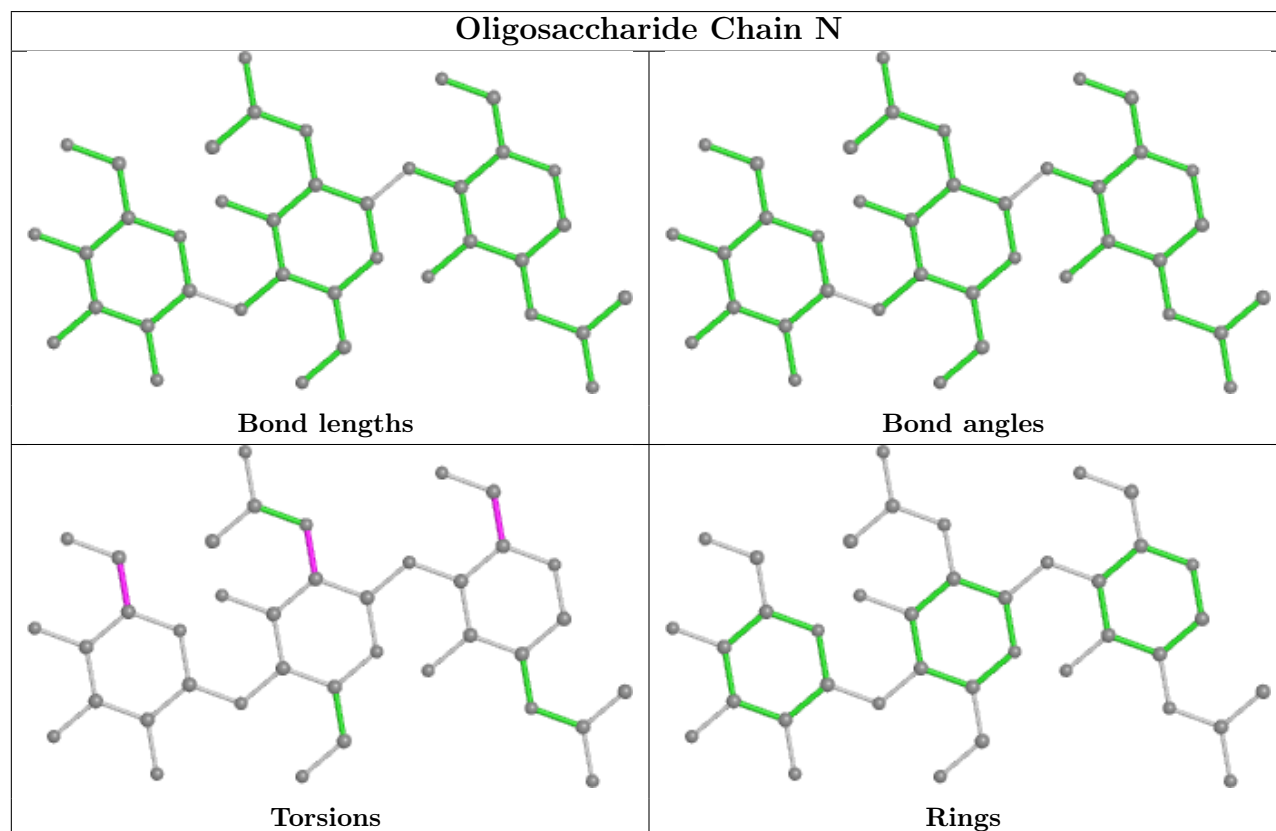
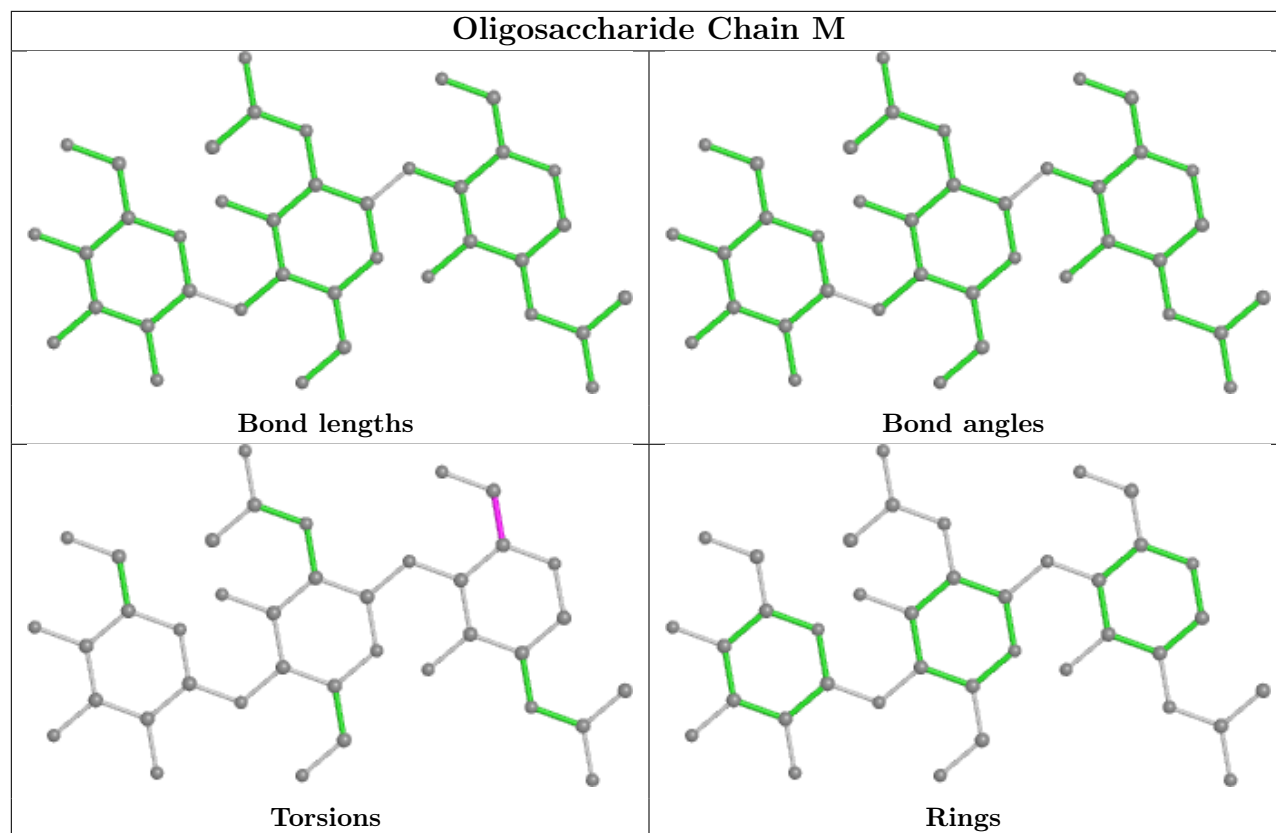

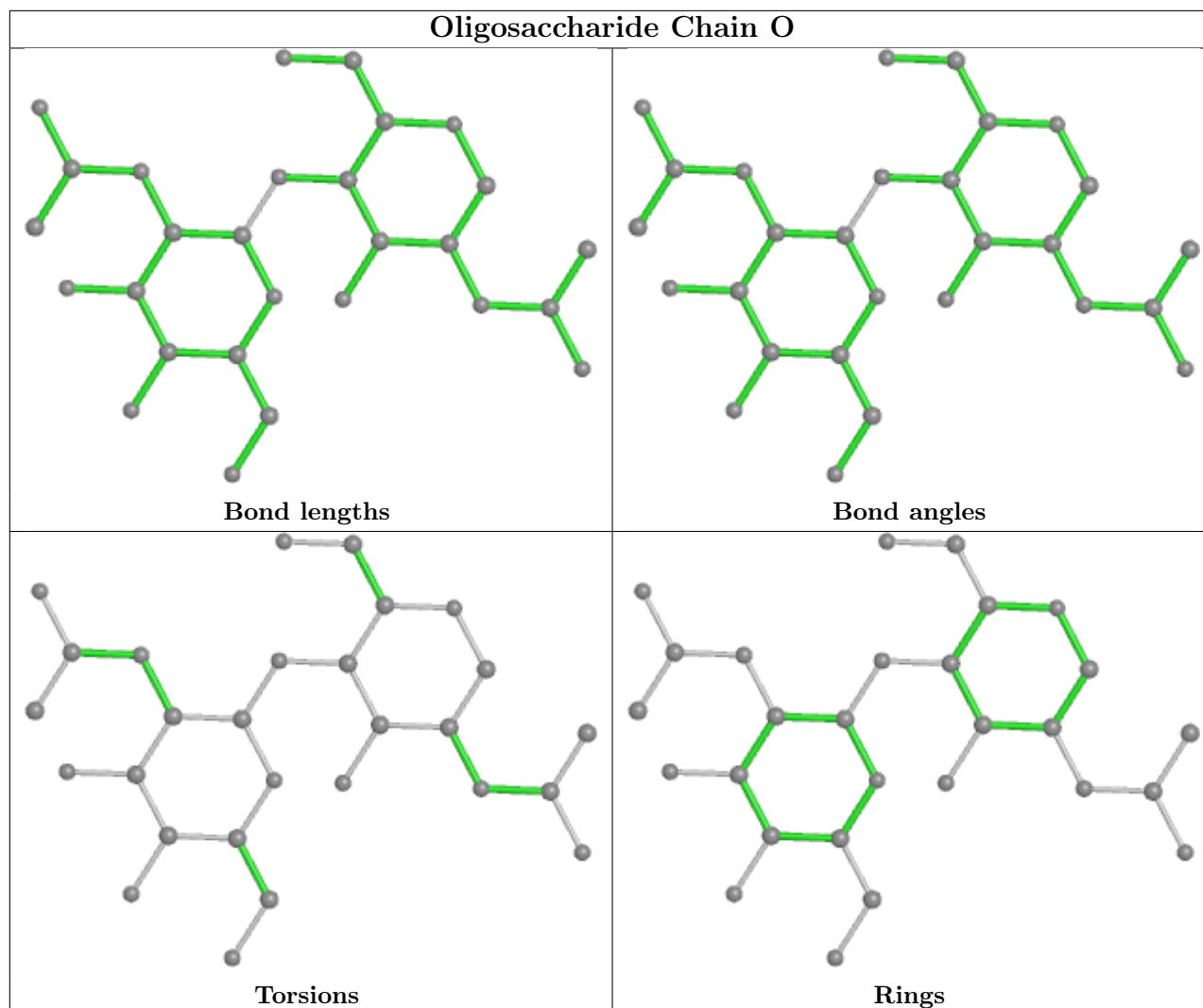

5.6 Ligand geometry [i](#)

5 ligands are modelled in this entry.

In the following table, the Counts columns list the number of bonds (or angles) for which Mogul statistics could be retrieved, the number of bonds (or angles) that are observed in the model and the number of bonds (or angles) that are defined in the Chemical Component Dictionary. The Link column lists molecule types, if any, to which the group is linked. The Z score for a bond length (or angle) is the number of standard deviations the observed value is removed from the expected value. A bond length (or angle) with $|Z| > 2$ is considered an outlier worth inspection. RMSZ is the root-mean-square of all Z scores of the bond lengths (or angles).

Mol	Type	Chain	Res	Link	Bond lengths			Bond angles		
					Counts	RMSZ	$\# Z > 2$	Counts	RMSZ	$\# Z > 2$
7	NAG	I	301	3	14,14,15	0.16	0	17,19,21	0.65	0
6	FUC	G	304	-	10,10,11	0.77	0	14,14,16	0.80	0
7	NAG	J	303	3	14,14,15	0.34	0	17,19,21	0.58	0
7	NAG	G	305	3	14,14,15	0.29	0	17,19,21	0.33	0

Mol	Type	Chain	Res	Link	Bond lengths			Bond angles		
					Counts	RMSZ	# Z > 2	Counts	RMSZ	# Z > 2
7	NAG	K	301	3	14,14,15	0.25	0	17,19,21	0.43	0

In the following table, the Chirals column lists the number of chiral outliers, the number of chiral centers analysed, the number of these observed in the model and the number defined in the Chemical Component Dictionary. Similar counts are reported in the Torsion and Rings columns. '-' means no outliers of that kind were identified.

Mol	Type	Chain	Res	Link	Chirals	Torsions	Rings
7	NAG	I	301	3	-	3/6/23/26	0/1/1/1
6	FUC	G	304	-	-	-	0/1/1/1
7	NAG	J	303	3	-	1/6/23/26	0/1/1/1
7	NAG	G	305	3	-	0/6/23/26	0/1/1/1
7	NAG	K	301	3	-	2/6/23/26	0/1/1/1

There are no bond length outliers.

There are no bond angle outliers.

There are no chirality outliers.

5 of 6 torsion outliers are listed below:

Mol	Chain	Res	Type	Atoms
7	K	301	NAG	C4-C5-C6-O6
7	I	301	NAG	O5-C5-C6-O6
7	I	301	NAG	C4-C5-C6-O6
7	K	301	NAG	O5-C5-C6-O6
7	J	303	NAG	O5-C5-C6-O6

There are no ring outliers.

2 monomers are involved in 2 short contacts:

Mol	Chain	Res	Type	Clashes	Symm-Clashes
7	I	301	NAG	0	1
7	K	301	NAG	1	0

5.7 Other polymers [i](#)

There are no such residues in this entry.

5.8 Polymer linkage issues

There are no chain breaks in this entry.

6 Fit of model and data [i](#)

6.1 Protein, DNA and RNA chains [i](#)

In the following table, the column labelled ‘#RSRZ> 2’ contains the number (and percentage) of RSRZ outliers, followed by percent RSRZ outliers for the chain as percentile scores relative to all X-ray entries and entries of similar resolution. The OWAB column contains the minimum, median, 95th percentile and maximum values of the occupancy-weighted average B-factor per residue. The column labelled ‘Q< 0.9’ lists the number of (and percentage) of residues with an average occupancy less than 0.9.

Mol	Chain	Analysed	<RSRZ>	#RSRZ>2	OWAB(Å ²)	Q<0.9
1	A	223/225 (99%)	0.30	8 (3%) 42 37	46, 74, 118, 246	0
1	C	223/225 (99%)	0.25	11 (4%) 29 26	50, 74, 128, 214	0
1	E	220/225 (97%)	0.52	9 (4%) 37 32	69, 106, 137, 206	0
1	H	223/225 (99%)	0.29	10 (4%) 33 29	43, 62, 116, 226	0
2	B	213/214 (99%)	-0.11	0 100 100	46, 59, 81, 116	0
2	D	213/214 (99%)	-0.08	0 100 100	46, 62, 87, 103	0
2	F	213/214 (99%)	0.01	2 (0%) 84 84	50, 66, 121, 137	0
2	L	213/214 (99%)	-0.14	1 (0%) 91 91	38, 52, 75, 86	0
3	G	195/223 (87%)	0.52	17 (8%) 10 7	49, 98, 168, 194	0
3	I	193/223 (86%)	1.11	44 (22%) 0 0	68, 126, 191, 227	0
3	J	195/223 (87%)	1.31	55 (28%) 0 0	66, 153, 188, 205	0
3	K	188/223 (84%)	1.61	66 (35%) 0 0	76, 170, 212, 228	0
All	All	2512/2648 (94%)	0.44	223 (8%) 9 7	38, 77, 181, 246	0

The worst 5 of 223 RSRZ outliers are listed below:

Mol	Chain	Res	Type	RSRZ
3	I	48	ASN	11.6
1	A	91	SER	11.0
1	E	91	SER	9.9
3	I	139	TYR	9.4
1	C	91	SER	9.2

6.2 Non-standard residues in protein, DNA, RNA chains [i](#)

There are no non-standard protein/DNA/RNA residues in this entry.

6.3 Carbohydrates [i](#)

In the following table, the Atoms column lists the number of modelled atoms in the group and the number defined in the chemical component dictionary. The B-factors column lists the minimum, median, 95th percentile and maximum values of B factors of atoms in the group. The column labelled 'Q<0.9' lists the number of atoms with occupancy less than 0.9.

Mol	Type	Chain	Res	Atoms	RSCC	RSR	B-factors(Å ²)	Q<0.9
4	NAG	N	2	14/15	0.69	0.41	117,130,132,134	0
5	NAG	O	1	14/15	0.73	0.18	93,110,116,122	0
4	BMA	N	3	11/12	0.74	0.21	118,122,128,128	0
4	BMA	M	3	11/12	0.74	0.13	99,108,110,112	0
5	NAG	O	2	14/15	0.80	0.18	112,121,122,124	0
4	NAG	N	1	14/15	0.81	0.18	88,102,112,118	0
4	NAG	M	2	14/15	0.85	0.16	95,101,107,108	0
4	NAG	M	1	14/15	0.89	0.18	67,81,92,93	0

The following is a graphical depiction of the model fit to experimental electron density for oligosaccharide. Each fit is shown from different orientation to approximate a three-dimensional view.

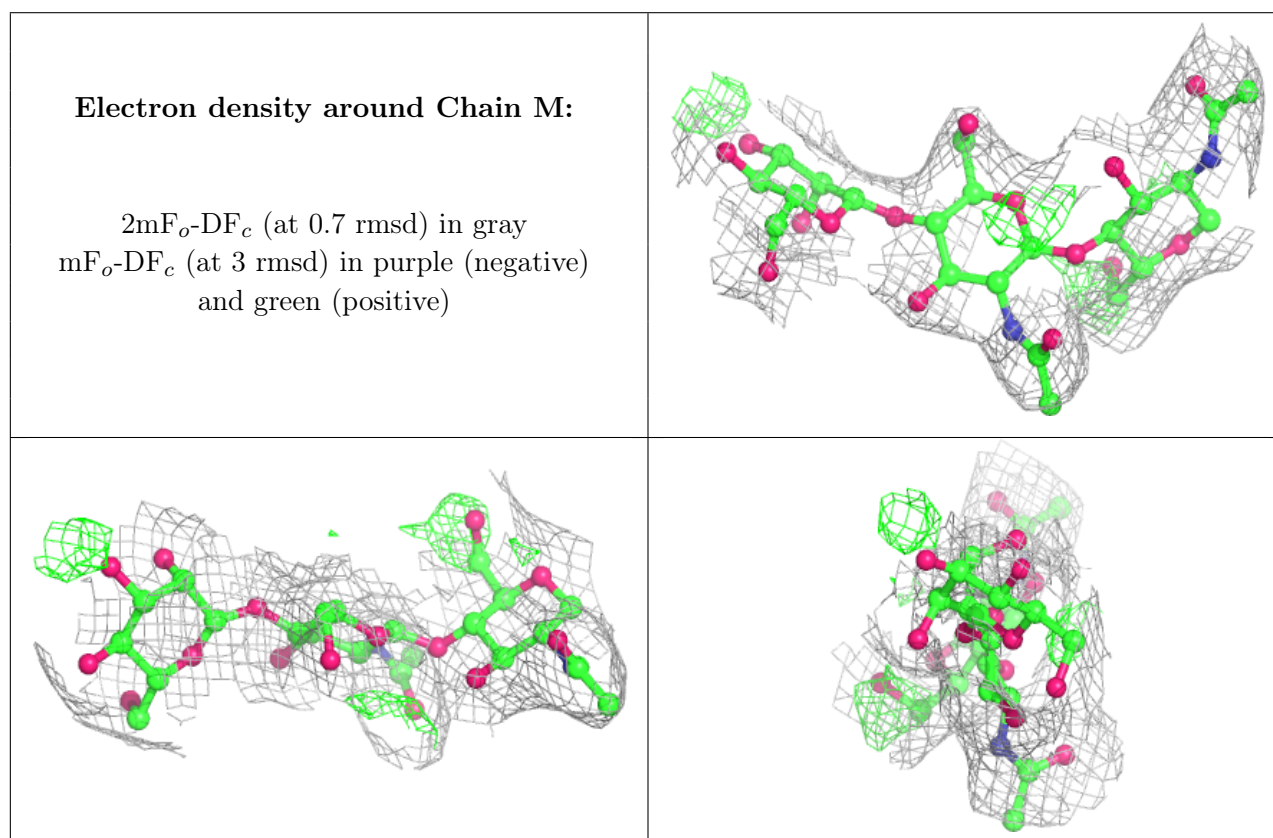

Electron density around Chain N:

$2mF_o-DF_c$ (at 0.7 rmsd) in gray
 mF_o-DF_c (at 3 rmsd) in purple (negative)
and green (positive)

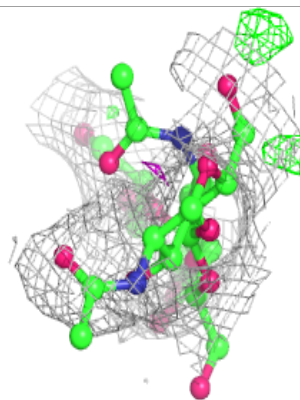
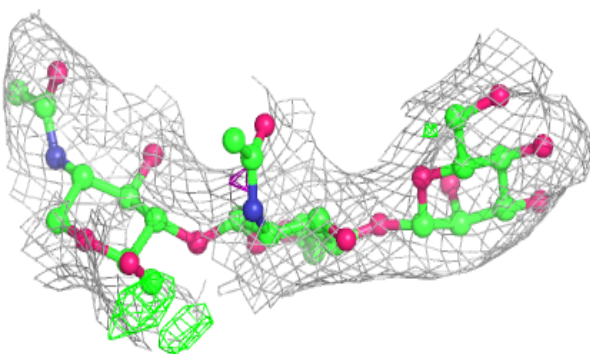
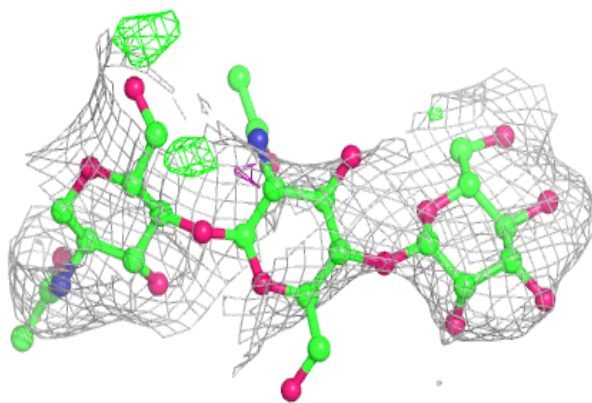

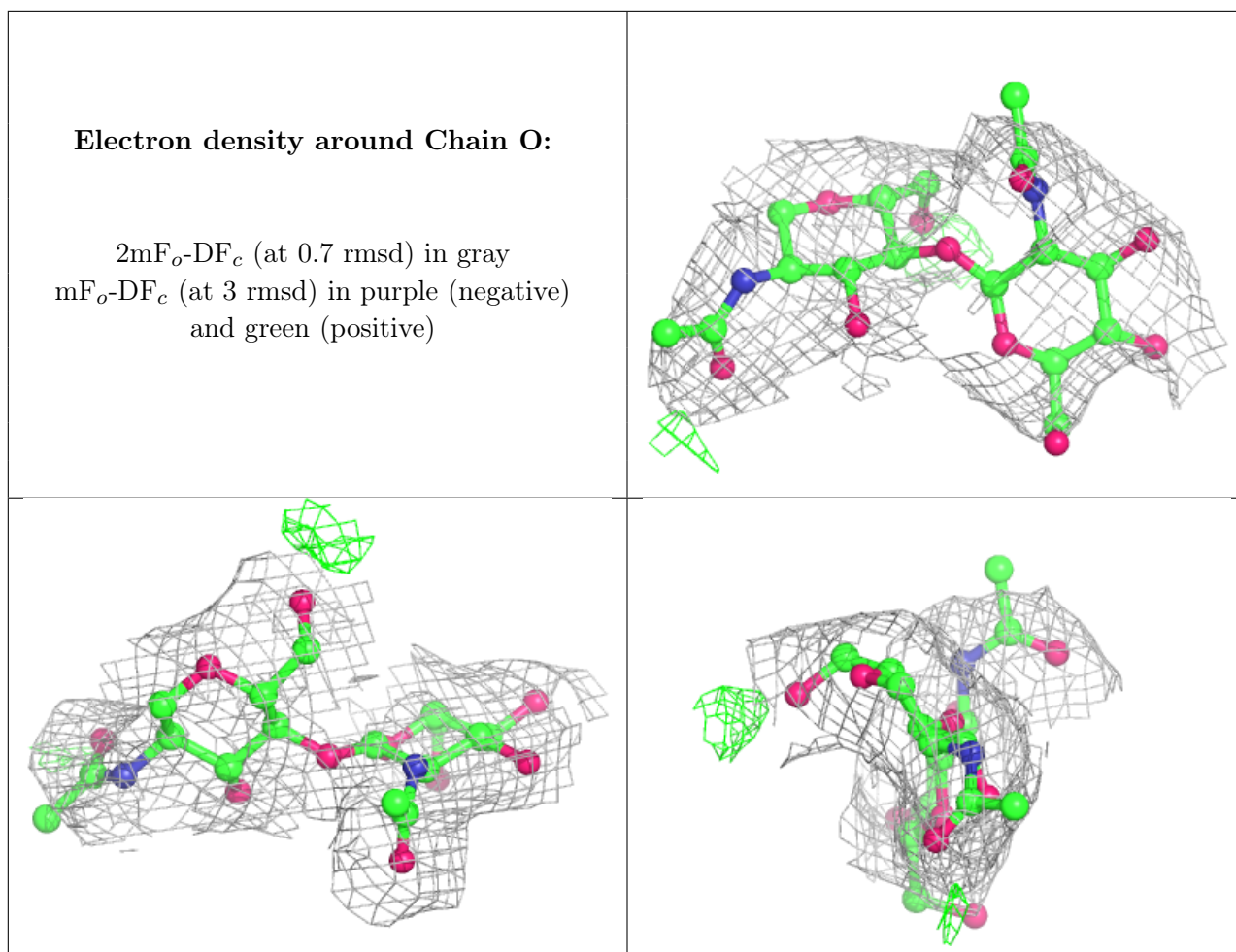

6.4 Ligands [i](#)

In the following table, the Atoms column lists the number of modelled atoms in the group and the number defined in the chemical component dictionary. The B-factors column lists the minimum, median, 95th percentile and maximum values of B factors of atoms in the group. The column labelled 'Q < 0.9' lists the number of atoms with occupancy less than 0.9.

Mol	Type	Chain	Res	Atoms	RSCC	RSR	B-factors(Å ²)	Q<0.9
7	NAG	J	303	14/15	0.18	0.38	131,155,165,169	0
7	NAG	G	305	14/15	0.48	0.30	127,143,149,151	0
7	NAG	I	301	14/15	0.51	0.41	134,158,181,187	0
6	FUC	G	304	10/11	0.76	0.21	93,109,112,112	0
7	NAG	K	301	14/15	0.79	0.23	101,113,116,131	0

6.5 Other polymers [i](#)

There are no such residues in this entry.