



Full wwPDB X-ray Structure Validation Report ⓘ

Aug 29, 2023 – 12:51 PM EDT

PDB ID : 3OA2
Title : Crystal structure of the WlbA (WbpB) dehydrogenase from *Pseudomonas aeruginosa* in complex with NAD at 1.5 angstrom resolution
Authors : Holden, H.M.; Thoden, J.B.
Deposited on : 2010-08-04
Resolution : 1.50 Å (reported)

This is a Full wwPDB X-ray Structure Validation Report for a publicly released PDB entry.

We welcome your comments at validation@mail.wwpdb.org

A user guide is available at

<https://www.wwpdb.org/validation/2017/XrayValidationReportHelp>

with specific help available everywhere you see the ⓘ symbol.

The types of validation reports are described at

<http://www.wwpdb.org/validation/2017/FAQs#types>.

The following versions of software and data (see [references ⓘ](#)) were used in the production of this report:

MolProbity : 4.02b-467
Mogul : 1.8.5 (274361), CSD as541be (2020)
Xtriage (Phenix) : 1.13
EDS : 2.35
buster-report : 1.1.7 (2018)
Percentile statistics : 20191225.v01 (using entries in the PDB archive December 25th 2019)
Refmac : 5.8.0158
CCP4 : 7.0.044 (Gargrove)
Ideal geometry (proteins) : Engh & Huber (2001)
Ideal geometry (DNA, RNA) : Parkinson et al. (1996)
Validation Pipeline (wwPDB-VP) : 2.35

1 Overall quality at a glance i

The following experimental techniques were used to determine the structure:

X-RAY DIFFRACTION

The reported resolution of this entry is 1.50 Å.

Percentile scores (ranging between 0-100) for global validation metrics of the entry are shown in the following graphic. The table shows the number of entries on which the scores are based.

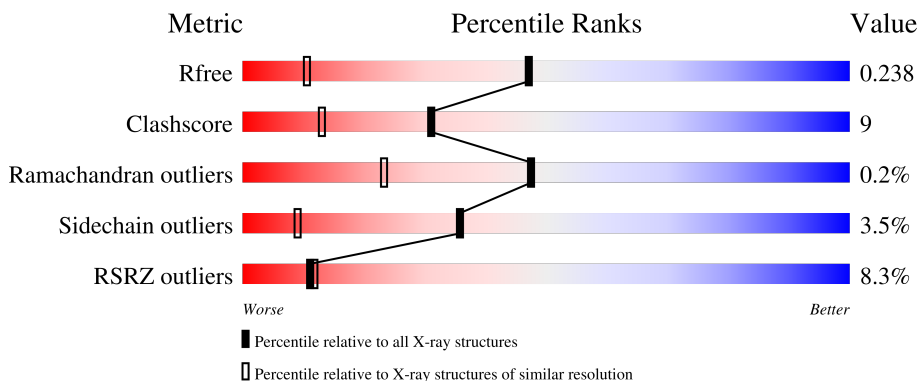

Metric	Whole archive (#Entries)	Similar resolution (#Entries, resolution range(Å))
R_{free}	130704	2936 (1.50-1.50)
Clashscore	141614	3144 (1.50-1.50)
Ramachandran outliers	138981	3066 (1.50-1.50)
Sidechain outliers	138945	3064 (1.50-1.50)
RSRZ outliers	127900	2884 (1.50-1.50)

The table below summarises the geometric issues observed across the polymeric chains and their fit to the electron density. The red, orange, yellow and green segments of the lower bar indicate the fraction of residues that contain outliers for ≥ 3 , 2, 1 and 0 types of geometric quality criteria respectively. A grey segment represents the fraction of residues that are not modelled. The numeric value for each fraction is indicated below the corresponding segment, with a dot representing fractions $\leq 5\%$. The upper red bar (where present) indicates the fraction of residues that have poor fit to the electron density. The numeric value is given above the bar.

Mol	Chain	Length	Quality of chain
1	A	318	<div style="display: flex; align-items: center;"> <div style="width: 7%; height: 10px; background-color: red; margin-right: 5px;"></div> <div style="width: 82%; height: 10px; background-color: green; margin-right: 5px;"></div> <div style="width: 12%; height: 10px; background-color: yellow; margin-right: 5px;"></div> <div style="width: 3%; height: 10px; background-color: orange; margin-right: 5px;"></div> <div style="width: 2%; height: 10px; background-color: grey;"></div> </div> <p style="text-align: center;">7% 82% 12% ••</p>
1	B	318	<div style="display: flex; align-items: center;"> <div style="width: 6%; height: 10px; background-color: red; margin-right: 5px;"></div> <div style="width: 84%; height: 10px; background-color: green; margin-right: 5px;"></div> <div style="width: 12%; height: 10px; background-color: yellow; margin-right: 5px;"></div> <div style="width: 3%; height: 10px; background-color: orange; margin-right: 5px;"></div> <div style="width: 2%; height: 10px; background-color: grey;"></div> </div> <p style="text-align: center;">6% 84% 12% ••</p>
1	C	318	<div style="display: flex; align-items: center;"> <div style="width: 5%; height: 10px; background-color: red; margin-right: 5px;"></div> <div style="width: 85%; height: 10px; background-color: green; margin-right: 5px;"></div> <div style="width: 8%; height: 10px; background-color: yellow; margin-right: 5px;"></div> <div style="width: 3%; height: 10px; background-color: orange; margin-right: 5px;"></div> <div style="width: 6%; height: 10px; background-color: grey;"></div> </div> <p style="text-align: center;">5% 85% 8% • 6%</p>
1	D	318	<div style="display: flex; align-items: center;"> <div style="width: 13%; height: 10px; background-color: red; margin-right: 5px;"></div> <div style="width: 73%; height: 10px; background-color: green; margin-right: 5px;"></div> <div style="width: 19%; height: 10px; background-color: yellow; margin-right: 5px;"></div> <div style="width: 3%; height: 10px; background-color: orange; margin-right: 5px;"></div> <div style="width: 6%; height: 10px; background-color: grey;"></div> </div> <p style="text-align: center;">13% 73% 19% • 6%</p>

2 Entry composition

There are 3 unique types of molecules in this entry. The entry contains 10958 atoms, of which 0 are hydrogens and 0 are deuteriums.

In the tables below, the ZeroOcc column contains the number of atoms modelled with zero occupancy, the AltConf column contains the number of residues with at least one atom in alternate conformation and the Trace column contains the number of residues modelled with at most 2 atoms.

- Molecule 1 is a protein called WbpB.

Mol	Chain	Residues	Atoms					ZeroOcc	AltConf	Trace
			Total	C	N	O	S			
1	A	306	2453	1563	421	457	12	0	2	0
1	B	311	2484	1582	429	461	12	0	2	0
1	C	299	2427	1548	420	447	12	0	5	0
1	D	298	2401	1531	412	446	12	0	5	0

There are 8 discrepancies between the modelled and reference sequences:

Chain	Residue	Modelled	Actual	Comment	Reference
A	-1	GLY	-	expression tag	UNP P72133
A	0	HIS	-	expression tag	UNP P72133
B	-1	GLY	-	expression tag	UNP P72133
B	0	HIS	-	expression tag	UNP P72133
C	-1	GLY	-	expression tag	UNP P72133
C	0	HIS	-	expression tag	UNP P72133
D	-1	GLY	-	expression tag	UNP P72133
D	0	HIS	-	expression tag	UNP P72133

- Molecule 2 is NICOTINAMIDE-ADENINE-DINUCLEOTIDE (three-letter code: NAD) (formula: C₂₁H₂₇N₇O₁₄P₂).

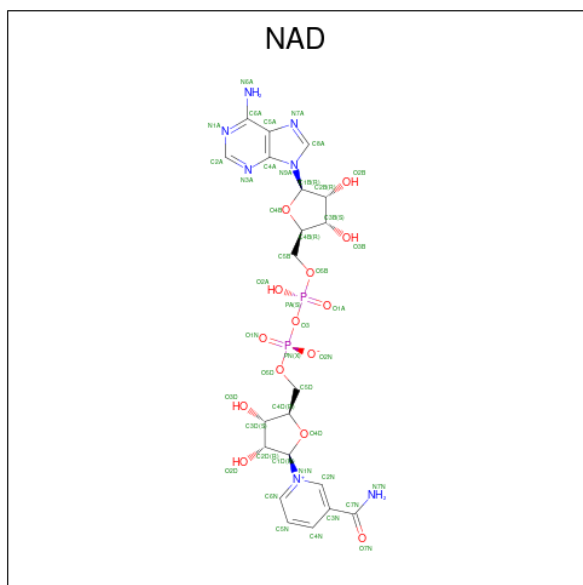

Mol	Chain	Residues	Atoms				ZeroOcc	AltConf	
			Total	C	N	O			P
2	A	1	44	21	7	14	2	0	0
2	B	1	44	21	7	14	2	0	0
2	C	1	44	21	7	14	2	0	0
2	D	1	44	21	7	14	2	0	0

- Molecule 3 is water.

Mol	Chain	Residues	Atoms		ZeroOcc	AltConf
			Total	O		
3	A	293	293	293	0	0
3	B	267	267	267	0	0
3	C	278	278	278	0	0
3	D	179	179	179	0	0

3 Residue-property plots [i](#)

These plots are drawn for all protein, RNA, DNA and oligosaccharide chains in the entry. The first graphic for a chain summarises the proportions of the various outlier classes displayed in the second graphic. The second graphic shows the sequence view annotated by issues in geometry and electron density. Residues are color-coded according to the number of geometric quality criteria for which they contain at least one outlier: green = 0, yellow = 1, orange = 2 and red = 3 or more. A red dot above a residue indicates a poor fit to the electron density ($RSRZ > 2$). Stretches of 2 or more consecutive residues without any outlier are shown as a green connector. Residues present in the sample, but not in the model, are shown in grey.

- Molecule 1: WbpB

Chain A: 

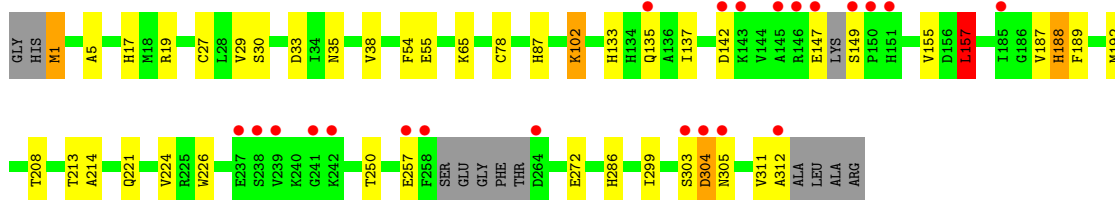

- Molecule 1: WbpB

Chain B: 

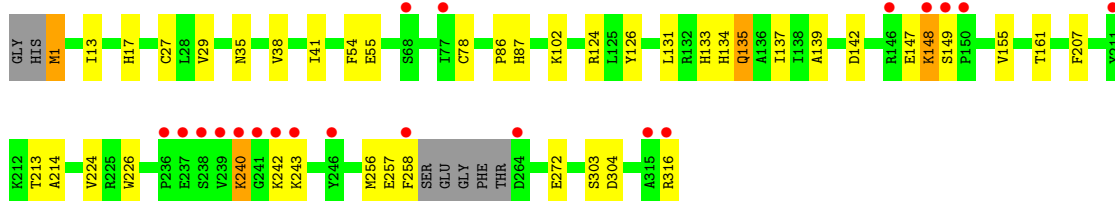

- Molecule 1: WbpB

Chain C: 

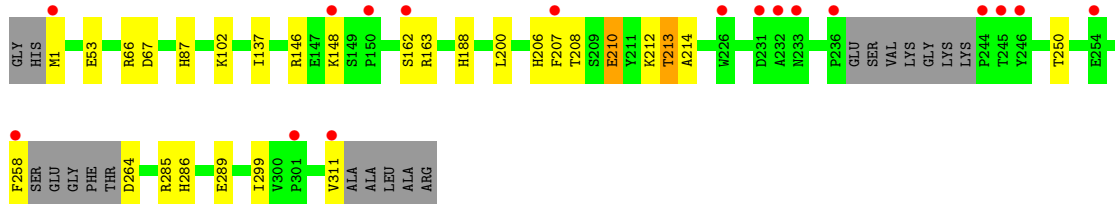

- Molecule 1: WbpB

Chain D: 



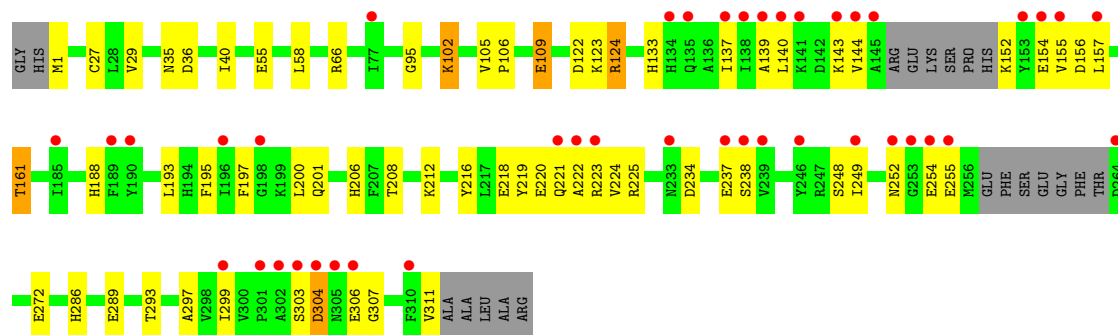

4 Data and refinement statistics

Property	Value	Source
Space group	P 21 21 21	Depositor
Cell constants a, b, c, α , β , γ	73.22Å 129.56Å 145.24Å 90.00° 90.00° 90.00°	Depositor
Resolution (Å)	30.00 – 1.50 27.00 – 1.50	Depositor EDS
% Data completeness (in resolution range)	93.1 (30.00-1.50) 93.1 (27.00-1.50)	Depositor EDS
R_{merge}	0.06	Depositor
R_{sym}	0.06	Depositor
$\langle I/\sigma(I) \rangle$ ¹	1.72 (at 1.50Å)	Xtrriage
Refinement program	REFMAC 5.5.0066	Depositor
R, R_{free}	0.201 , 0.244 0.197 , 0.238	Depositor DCC
R_{free} test set	10383 reflections (5.02%)	wwPDB-VP
Wilson B-factor (Å ²)	16.9	Xtrriage
Anisotropy	0.320	Xtrriage
Bulk solvent k_{sol} (e/Å ³), B_{sol} (Å ²)	0.38 , 51.2	EDS
L-test for twinning ²	$\langle L \rangle = 0.48$, $\langle L^2 \rangle = 0.31$	Xtrriage
Estimated twinning fraction	No twinning to report.	Xtrriage
F_o, F_c correlation	0.96	EDS
Total number of atoms	10958	wwPDB-VP
Average B, all atoms (Å ²)	28.0	wwPDB-VP

Xtrriage's analysis on translational NCS is as follows: *The largest off-origin peak in the Patterson function is 11.81% of the height of the origin peak. No significant pseudotranslation is detected.*

¹Intensities estimated from amplitudes.

²Theoretical values of $\langle |L| \rangle$, $\langle L^2 \rangle$ for acentric reflections are 0.5, 0.333 respectively for untwinned datasets, and 0.375, 0.2 for perfectly twinned datasets.

5 Model quality [i](#)

5.1 Standard geometry [i](#)

Bond lengths and bond angles in the following residue types are not validated in this section:
NAD

The Z score for a bond length (or angle) is the number of standard deviations the observed value is removed from the expected value. A bond length (or angle) with $|Z| > 5$ is considered an outlier worth inspection. RMSZ is the root-mean-square of all Z scores of the bond lengths (or angles).

Mol	Chain	Bond lengths		Bond angles	
		RMSZ	# Z >5	RMSZ	# Z >5
1	A	0.66	0/2518	0.79	2/3412 (0.1%)
1	B	0.66	0/2550	0.78	0/3456
1	C	0.67	0/2502	0.75	0/3390
1	D	0.56	0/2472	0.66	0/3349
All	All	0.64	0/10042	0.75	2/13607 (0.0%)

Chiral center outliers are detected by calculating the chiral volume of a chiral center and verifying if the center is modelled as a planar moiety or with the opposite hand. A planarity outlier is detected by checking planarity of atoms in a peptide group, atoms in a mainchain group or atoms of a sidechain that are expected to be planar.

Mol	Chain	#Chirality outliers	#Planarity outliers
1	B	0	1

There are no bond length outliers.

All (2) bond angle outliers are listed below:

Mol	Chain	Res	Type	Atoms	Z	Observed($^{\circ}$)	Ideal($^{\circ}$)
1	A	157	LEU	CA-CB-CG	7.33	132.16	115.30
1	A	33	ASP	CB-CG-OD2	5.82	123.54	118.30

There are no chirality outliers.

All (1) planarity outliers are listed below:

Mol	Chain	Res	Type	Group
1	B	303	SER	Peptide

5.2 Too-close contacts

In the following table, the Non-H and H(model) columns list the number of non-hydrogen atoms and hydrogen atoms in the chain respectively. The H(added) column lists the number of hydrogen atoms added and optimized by MolProbity. The Clashes column lists the number of clashes within the asymmetric unit, whereas Symm-Clashes lists symmetry-related clashes.

Mol	Chain	Non-H	H(model)	H(added)	Clashes	Symm-Clashes
1	A	2453	0	2398	39	0
1	B	2484	0	2431	36	0
1	C	2427	0	2377	36	0
1	D	2401	0	2364	74	0
2	A	44	0	26	0	0
2	B	44	0	26	0	0
2	C	44	0	26	0	0
2	D	44	0	26	0	0
3	A	293	0	0	7	0
3	B	267	0	0	0	0
3	C	278	0	0	7	0
3	D	179	0	0	7	0
All	All	10958	0	9674	179	0

The all-atom clashscore is defined as the number of clashes found per 1000 atoms (including hydrogen atoms). The all-atom clashscore for this structure is 9.

All (179) close contacts within the same asymmetric unit are listed below, sorted by their clash magnitude.

Atom-1	Atom-2	Interatomic distance (Å)	Clash overlap (Å)
1:A:35:ASN:HB3	3:A:402:HOH:O	1.29	1.22
1:C:137:ILE:CD1	1:C:258:PHE:HE1	1.55	1.20
1:C:137:ILE:HD11	1:C:258:PHE:CE1	1.82	1.14
1:B:35:ASN:ND2	1:D:35[B]:ASN:OD1	1.81	1.13
1:D:124:ARG:HG3	1:D:124:ARG:HH21	1.10	1.11
1:C:137:ILE:HD11	1:C:258:PHE:HE1	1.01	1.10
1:D:216:TYR:CE2	1:D:218:GLU:CG	2.39	1.06
1:B:139:ALA:O	1:B:142:ASP:OD2	1.74	1.04
1:D:216:TYR:OH	1:D:223:ARG:HG3	1.59	1.02
1:C:53:GLU:OE2	3:C:752:HOH:O	1.77	0.99
1:D:216:TYR:CZ	1:D:218:GLU:HG2	1.98	0.97
1:A:213:THR:HG22	1:A:226:TRP:CH2	1.98	0.97
1:D:216:TYR:HE2	1:D:218:GLU:HG3	1.30	0.97
1:D:216:TYR:HH	1:D:223:ARG:HG3	1.32	0.94
1:D:216:TYR:CE2	1:D:218:GLU:HG3	2.03	0.93

Continued on next page...

Continued from previous page...

Atom-1	Atom-2	Interatomic distance (Å)	Clash overlap (Å)
1:D:216:TYR:CE2	1:D:218:GLU:HG2	2.01	0.93
1:D:208:THR:HG22	1:D:299:ILE:HD11	1.49	0.92
1:C:207:PHE:HA	1:C:299:ILE:CD1	1.99	0.92
1:A:213:THR:HG22	1:A:226:TRP:CZ3	2.05	0.91
1:A:213:THR:CG2	1:A:226:TRP:CH2	2.54	0.89
1:D:216:TYR:HE2	1:D:218:GLU:CG	1.81	0.89
1:C:163[B]:ARG:NH2	3:C:543:HOH:O	2.05	0.89
1:C:137:ILE:CD1	1:C:258:PHE:CE1	2.47	0.89
1:C:264:ASP:HB3	3:C:418:HOH:O	1.74	0.88
1:C:264:ASP:HB3	3:C:630:HOH:O	1.75	0.86
1:D:124:ARG:HH21	1:D:124:ARG:CG	1.88	0.86
1:B:213:THR:HG22	1:B:226:TRP:CH2	2.10	0.85
1:D:154:GLU:HB3	1:D:252:ASN:HA	1.56	0.85
1:D:154:GLU:HA	1:D:154:GLU:OE1	1.79	0.81
1:A:213:THR:HG21	1:A:226:TRP:HH2	1.45	0.80
1:D:216:TYR:OH	1:D:218:GLU:HG2	1.82	0.80
1:A:213:THR:CG2	1:A:226:TRP:HH2	1.92	0.79
1:D:124:ARG:HG3	1:D:124:ARG:NH2	1.92	0.77
1:A:1:MET:HE2	3:A:573:HOH:O	1.85	0.76
1:C:207:PHE:HA	1:C:299:ILE:HD13	1.66	0.76
1:D:140:LEU:HD12	1:D:140:LEU:O	1.86	0.75
1:D:66:ARG:HD2	3:D:864:HOH:O	1.86	0.74
1:A:147:GLU:O	1:A:149:SER:N	2.21	0.74
1:A:65:LYS:HE2	3:A:977:HOH:O	1.87	0.74
1:C:208:THR:HA	1:C:213:THR:HG23	1.70	0.73
1:A:303:SER:O	1:A:305:ASN:N	2.23	0.72
1:B:124:ARG:HD3	1:B:126:TYR:OH	1.89	0.72
1:D:140:LEU:HD12	1:D:144:VAL:HG23	1.70	0.72
1:D:156:ASP:OD2	1:D:225:ARG:NH1	2.22	0.71
1:D:216:TYR:OH	1:D:223:ARG:CG	2.36	0.71
1:A:213:THR:CG2	1:A:214:ALA:N	2.54	0.70
1:C:137:ILE:HD12	1:C:258:PHE:HE1	1.52	0.69
1:D:155:VAL:HB	1:D:224:VAL:HG22	1.75	0.69
1:A:147:GLU:C	1:A:149:SER:N	2.48	0.67
1:D:95:GLY:O	1:D:123:LYS:HE3	1.96	0.66
1:D:154:GLU:HB2	1:D:252:ASN:OD1	1.95	0.66
1:A:1:MET:CE	3:A:573:HOH:O	2.42	0.66
1:B:27[B]:CYS:SG	1:B:29:VAL:HG12	2.37	0.65
1:B:213:THR:CG2	1:B:226:TRP:CH2	2.80	0.65
1:B:124:ARG:HD3	1:B:126:TYR:CZ	2.31	0.65
1:A:213:THR:HG22	1:A:214:ALA:N	2.12	0.65

Continued on next page...

Continued from previous page...

Atom-1	Atom-2	Interatomic distance (Å)	Clash overlap (Å)
1:B:213:THR:CG2	1:B:226:TRP:HH2	2.09	0.65
1:A:286:HIS:CD2	3:A:358:HOH:O	2.49	0.64
1:D:201:GLN:NE2	1:D:220:GLU:HA	2.12	0.64
1:B:242:LYS:HB3	1:B:242:LYS:HZ3	1.62	0.64
1:D:139:ALA:O	1:D:143:LYS:HB2	1.97	0.64
1:D:216:TYR:CZ	1:D:223:ARG:HG3	2.33	0.64
1:C:207:PHE:HA	1:C:299:ILE:HD11	1.80	0.63
1:D:286:HIS:NE2	3:D:340:HOH:O	2.31	0.63
1:D:140:LEU:CD1	1:D:144:VAL:HG23	2.31	0.61
1:D:40:ILE:HD12	3:D:855:HOH:O	2.01	0.61
1:C:207:PHE:CA	1:C:299:ILE:CD1	2.76	0.60
1:D:124:ARG:CG	1:D:124:ARG:NH2	2.56	0.60
1:C:206:HIS:C	1:C:299:ILE:HD13	2.22	0.60
1:B:27[B]:CYS:SG	1:B:29:VAL:CG1	2.90	0.60
1:C:207:PHE:CA	1:C:299:ILE:HD13	2.31	0.60
1:B:139:ALA:C	1:B:142:ASP:OD2	2.42	0.58
1:A:55:GLU:HG2	1:B:87:HIS:CD2	2.38	0.57
1:C:206:HIS:O	1:C:299:ILE:HD13	2.05	0.57
1:D:216:TYR:HH	1:D:218:GLU:HG2	1.69	0.57
1:D:133:HIS:CE1	1:D:272:GLU:HG3	2.40	0.57
1:D:311:VAL:HG12	1:D:311:VAL:O	2.05	0.56
1:C:67:ASP:HB2	3:C:491:HOH:O	2.04	0.56
1:A:221:GLN:NE2	3:A:492:HOH:O	2.34	0.56
1:C:208:THR:CA	1:C:213:THR:HG23	2.38	0.54
1:D:286:HIS:CD2	3:D:340:HOH:O	2.60	0.54
1:C:210:GLU:N	1:C:210:GLU:OE2	2.40	0.54
1:C:188:HIS:H	1:C:188:HIS:CD2	2.26	0.53
1:D:212:LYS:HE2	1:D:234:ASP:OD2	2.07	0.53
1:D:154:GLU:HB3	1:D:252:ASN:CA	2.33	0.53
1:C:208:THR:CB	1:C:213:THR:HG23	2.39	0.53
1:D:216:TYR:OH	1:D:218:GLU:CG	2.54	0.53
1:C:137:ILE:HD12	1:C:258:PHE:CE1	2.34	0.52
1:B:207:PHE:O	1:B:213:THR:HG23	2.10	0.52
1:D:195:PHE:HE2	3:D:648:HOH:O	1.91	0.52
1:A:55:GLU:HB3	1:B:86:PRO:HB2	1.92	0.51
1:B:213:THR:HG22	1:B:214:ALA:N	2.25	0.51
1:B:131:LEU:HB3	1:B:137:ILE:CD1	2.41	0.51
1:D:201:GLN:HE21	1:D:220:GLU:HA	1.76	0.50
1:D:303:SER:O	1:D:304:ASP:HB2	2.11	0.50
1:D:35[B]:ASN:HD22	1:D:36:ASP:N	2.10	0.50
1:B:242:LYS:HB3	1:B:242:LYS:NZ	2.21	0.50

Continued on next page...

Continued from previous page...

Atom-1	Atom-2	Interatomic distance (Å)	Clash overlap (Å)
1:B:147:GLU:O	1:B:148:LYS:C	2.50	0.49
1:A:87:HIS:CD2	1:B:55:GLU:HG2	2.46	0.49
1:A:188:HIS:H	1:A:188:HIS:CD2	2.29	0.49
1:D:161:THR:CG2	1:D:161:THR:O	2.60	0.49
1:A:213:THR:CG2	1:A:226:TRP:CZ3	2.86	0.49
1:D:27[B]:CYS:SG	1:D:29:VAL:HG12	2.52	0.49
1:D:216:TYR:CZ	1:D:218:GLU:CG	2.75	0.49
1:A:102:LYS:HD3	1:A:187:VAL:CG1	2.43	0.49
1:D:140:LEU:O	1:D:144:VAL:HG23	2.14	0.48
1:D:154:GLU:CB	1:D:252:ASN:HA	2.35	0.48
1:D:216:TYR:CE1	1:D:223:ARG:HG3	2.47	0.48
1:D:237:GLU:HA	1:D:237:GLU:OE1	2.12	0.48
1:D:311:VAL:O	1:D:311:VAL:CG1	2.61	0.48
1:B:147:GLU:O	1:B:149:SER:N	2.47	0.48
1:D:154:GLU:OE1	1:D:154:GLU:CA	2.48	0.47
1:D:216:TYR:OH	1:D:223:ARG:CD	2.62	0.47
1:C:207:PHE:CA	1:C:299:ILE:HD11	2.42	0.47
1:B:139:ALA:HA	1:B:142:ASP:OD2	2.15	0.47
1:C:250:THR:HG21	3:C:530:HOH:O	2.15	0.47
1:A:54:PHE:HD1	1:B:54:PHE:HD1	1.62	0.47
1:B:124:ARG:HG3	1:B:126:TYR:CE2	2.50	0.47
1:D:201:GLN:NE2	1:D:219:TYR:O	2.48	0.47
1:A:1:MET:HG3	3:A:683:HOH:O	2.15	0.47
1:A:17:HIS:CD2	1:A:78[B]:CYS:SG	3.09	0.46
1:B:213:THR:CG2	1:B:214:ALA:N	2.78	0.46
1:C:207:PHE:O	1:C:213:THR:HG22	2.16	0.46
1:B:161:THR:O	1:B:161:THR:HG23	2.16	0.46
1:D:221:GLN:HE21	1:D:221:GLN:HA	1.80	0.46
1:A:213:THR:HG21	1:A:226:TRP:CH2	2.30	0.46
1:A:157:LEU:HD21	1:A:189:PHE:HB3	1.98	0.46
1:C:87:HIS:CD2	1:D:55:GLU:HG2	2.51	0.46
1:D:206:HIS:CD2	1:D:307:GLY:HA2	2.51	0.46
1:D:293:THR:O	1:D:297:ALA:HB2	2.16	0.46
1:D:102:LYS:O	1:D:102:LYS:HD2	2.16	0.45
1:B:1:MET:HE2	1:B:1:MET:HB3	1.52	0.45
1:C:214:ALA:HB3	1:C:311:VAL:HG21	1.99	0.45
1:D:155:VAL:O	1:D:224:VAL:HA	2.17	0.45
1:C:208:THR:N	1:C:299:ILE:HD11	2.31	0.44
1:A:133:HIS:CE1	1:A:272:GLU:HG3	2.52	0.44
1:C:285:ARG:O	1:C:289:GLU:HG3	2.17	0.44
1:B:213:THR:HG22	1:B:226:TRP:CZ3	2.49	0.44

Continued on next page...

Continued from previous page...

Atom-1	Atom-2	Interatomic distance (Å)	Clash overlap (Å)
1:B:213:THR:HG21	1:B:226:TRP:HH2	1.79	0.44
1:D:197:PHE:CD1	1:D:222:ALA:HB2	2.53	0.44
1:B:13:ILE:HD12	1:B:13:ILE:HA	1.89	0.43
1:D:40:ILE:HD11	3:D:848:HOH:O	2.18	0.43
1:D:193:LEU:CD1	1:D:224:VAL:HG11	2.48	0.43
1:A:311:VAL:O	1:A:312:ALA:C	2.55	0.43
1:D:152:LYS:HE2	1:D:219:TYR:O	2.18	0.43
1:C:207:PHE:CE1	1:C:212:LYS:HG3	2.53	0.43
1:D:200:LEU:HB2	1:D:286:HIS:HE1	1.83	0.43
1:D:105:VAL:HB	1:D:106:PRO:HD2	2.01	0.43
1:D:303:SER:O	1:D:306:GLU:HG3	2.19	0.43
1:D:248:SER:HA	1:D:255:GLU:OE2	2.18	0.43
1:A:137:ILE:HG12	1:A:192:MET:HG3	2.00	0.43
1:A:155:VAL:HA	1:A:250:THR:O	2.19	0.43
1:B:133:HIS:CE1	1:B:272:GLU:HG3	2.54	0.43
1:C:200:LEU:HB2	1:C:286[A]:HIS:CE1	2.55	0.42
1:D:193:LEU:HD13	1:D:224:VAL:HG11	2.00	0.42
1:A:38:VAL:HG22	1:A:38:VAL:O	2.20	0.42
1:A:213:THR:HG23	1:A:214:ALA:N	2.34	0.42
1:A:155:VAL:HB	1:A:224:VAL:HG22	2.02	0.42
1:D:197:PHE:O	1:D:219:TYR:HB3	2.19	0.42
1:A:208:THR:HG22	1:A:299:ILE:HD11	2.01	0.42
1:D:109:GLU:CA	1:D:109:GLU:OE1	2.68	0.41
1:A:27[B]:CYS:SG	1:A:29:VAL:CG1	3.08	0.41
1:B:134:HIS:CE1	1:B:258:PHE:HB2	2.55	0.41
1:A:303:SER:O	1:A:304:ASP:C	2.59	0.41
1:C:162:SER:C	1:C:163[B]:ARG:HG3	2.40	0.41
1:A:5:ALA:HA	1:A:30:SER:O	2.21	0.41
1:A:188:HIS:H	1:A:188:HIS:HD2	1.67	0.41
1:B:38:VAL:O	1:B:41:ILE:HG22	2.20	0.41
1:C:207:PHE:HE1	1:C:212:LYS:HG3	1.86	0.41
1:D:188:HIS:CE1	3:D:376:HOH:O	2.74	0.41
1:B:155:VAL:HB	1:B:224:VAL:HG22	2.03	0.41
1:B:240:LYS:C	1:B:242:LYS:H	2.24	0.41
1:B:17:HIS:CD2	1:B:78[A]:CYS:SG	3.14	0.40
1:D:27[B]:CYS:SG	1:D:29:VAL:CG1	3.09	0.40
1:B:135:GLN:HE21	1:B:135:GLN:HB3	1.73	0.40
1:C:66:ARG:HD2	3:C:881:HOH:O	2.21	0.40
1:C:207:PHE:HE1	1:C:212:LYS:CG	2.34	0.40
1:D:201:GLN:HE21	1:D:220:GLU:CA	2.34	0.40
1:D:35[B]:ASN:HD22	1:D:36:ASP:H	1.68	0.40

There are no symmetry-related clashes.

5.3 Torsion angles [i](#)

5.3.1 Protein backbone [i](#)

In the following table, the Percentiles column shows the percent Ramachandran outliers of the chain as a percentile score with respect to all X-ray entries followed by that with respect to entries of similar resolution.

The Analysed column shows the number of residues for which the backbone conformation was analysed, and the total number of residues.

Mol	Chain	Analysed	Favoured	Allowed	Outliers	Percentiles	
1	A	302/318 (95%)	295 (98%)	6 (2%)	1 (0%)	41	18
1	B	309/318 (97%)	299 (97%)	9 (3%)	1 (0%)	41	18
1	C	298/318 (94%)	294 (99%)	4 (1%)	0	100	100
1	D	297/318 (93%)	286 (96%)	11 (4%)	0	100	100
All	All	1206/1272 (95%)	1174 (97%)	30 (2%)	2 (0%)	47	23

All (2) Ramachandran outliers are listed below:

Mol	Chain	Res	Type
1	A	304	ASP
1	B	148	LYS

5.3.2 Protein sidechains [i](#)

In the following table, the Percentiles column shows the percent sidechain outliers of the chain as a percentile score with respect to all X-ray entries followed by that with respect to entries of similar resolution.

The Analysed column shows the number of residues for which the sidechain conformation was analysed, and the total number of residues.

Mol	Chain	Analysed	Rotameric	Outliers	Percentiles	
1	A	266/272 (98%)	258 (97%)	8 (3%)	41	12
1	B	267/272 (98%)	258 (97%)	9 (3%)	37	9
1	C	264/272 (97%)	258 (98%)	6 (2%)	50	20
1	D	262/272 (96%)	248 (95%)	14 (5%)	22	3
All	All	1059/1088 (97%)	1022 (96%)	37 (4%)	36	9

All (37) residues with a non-rotameric sidechain are listed below:

Mol	Chain	Res	Type
1	A	1	MET
1	A	19	ARG
1	A	102	LYS
1	A	135	GLN
1	A	142	ASP
1	A	157	LEU
1	A	188	HIS
1	A	257	GLU
1	B	1	MET
1	B	102	LYS
1	B	135	GLN
1	B	240	LYS
1	B	243	LYS
1	B	256	MET
1	B	257	GLU
1	B	304	ASP
1	B	316	ARG
1	C	1	MET
1	C	102	LYS
1	C	146	ARG
1	C	148	LYS
1	C	210	GLU
1	C	213	THR
1	D	1	MET
1	D	58	LEU
1	D	102	LYS
1	D	109	GLU
1	D	122	ASP
1	D	124	ARG
1	D	137	ILE
1	D	157	LEU
1	D	161	THR
1	D	238	SER
1	D	249	ILE
1	D	254	GLU
1	D	289	GLU
1	D	304	ASP

Sometimes sidechains can be flipped to improve hydrogen bonding and reduce clashes. All (11) such sidechains are listed below:

Mol	Chain	Res	Type
1	A	134	HIS
1	A	188	HIS
1	A	221	GLN
1	B	135	GLN
1	B	188	HIS
1	B	221	GLN
1	C	188	HIS
1	C	221	GLN
1	D	127	ASN
1	D	201	GLN
1	D	221	GLN

5.3.3 RNA [i](#)

There are no RNA molecules in this entry.

5.4 Non-standard residues in protein, DNA, RNA chains [i](#)

There are no non-standard protein/DNA/RNA residues in this entry.

5.5 Carbohydrates [i](#)

There are no monosaccharides in this entry.

5.6 Ligand geometry [i](#)

4 ligands are modelled in this entry.

In the following table, the Counts columns list the number of bonds (or angles) for which Mogul statistics could be retrieved, the number of bonds (or angles) that are observed in the model and the number of bonds (or angles) that are defined in the Chemical Component Dictionary. The Link column lists molecule types, if any, to which the group is linked. The Z score for a bond length (or angle) is the number of standard deviations the observed value is removed from the expected value. A bond length (or angle) with $|Z| > 2$ is considered an outlier worth inspection. RMSZ is the root-mean-square of all Z scores of the bond lengths (or angles).

Mol	Type	Chain	Res	Link	Bond lengths			Bond angles		
					Counts	RMSZ	# Z > 2	Counts	RMSZ	# Z > 2
2	NAD	B	317	-	42,48,48	1.09	2 (4%)	50,73,73	1.74	11 (22%)
2	NAD	D	317	-	42,48,48	0.90	1 (2%)	50,73,73	1.48	9 (18%)
2	NAD	C	317	-	42,48,48	1.27	5 (11%)	50,73,73	1.59	11 (22%)

Mol	Type	Chain	Res	Link	Bond lengths			Bond angles		
					Counts	RMSZ	# Z > 2	Counts	RMSZ	# Z > 2
2	NAD	A	317	-	42,48,48	1.30	4 (9%)	50,73,73	1.75	14 (28%)

In the following table, the Chirals column lists the number of chiral outliers, the number of chiral centers analysed, the number of these observed in the model and the number defined in the Chemical Component Dictionary. Similar counts are reported in the Torsion and Rings columns. '-' means no outliers of that kind were identified.

Mol	Type	Chain	Res	Link	Chirals	Torsions	Rings
2	NAD	B	317	-	-	6/26/62/62	0/5/5/5
2	NAD	D	317	-	-	7/26/62/62	0/5/5/5
2	NAD	C	317	-	-	6/26/62/62	0/5/5/5
2	NAD	A	317	-	-	5/26/62/62	0/5/5/5

All (12) bond length outliers are listed below:

Mol	Chain	Res	Type	Atoms	Z	Observed(Å)	Ideal(Å)
2	A	317	NAD	O4B-C1B	4.34	1.47	1.41
2	C	317	NAD	O4B-C1B	4.14	1.46	1.41
2	B	317	NAD	O4B-C1B	3.49	1.46	1.41
2	A	317	NAD	O4D-C1D	3.15	1.45	1.41
2	A	317	NAD	C8A-N7A	-2.87	1.29	1.34
2	C	317	NAD	O4D-C1D	2.60	1.44	1.41
2	B	317	NAD	O4D-C1D	2.43	1.44	1.41
2	D	317	NAD	O4D-C1D	2.36	1.44	1.41
2	C	317	NAD	C8A-N7A	-2.35	1.30	1.34
2	A	317	NAD	C7N-N7N	2.34	1.37	1.33
2	C	317	NAD	C3N-C7N	-2.17	1.47	1.50
2	C	317	NAD	C7N-N7N	2.01	1.36	1.33

All (45) bond angle outliers are listed below:

Mol	Chain	Res	Type	Atoms	Z	Observed(°)	Ideal(°)
2	B	317	NAD	C1B-N9A-C4A	-4.85	118.11	126.64
2	B	317	NAD	O4B-C1B-C2B	-4.85	99.84	106.93
2	A	317	NAD	N3A-C2A-N1A	-4.47	121.70	128.68
2	D	317	NAD	O4B-C1B-C2B	-4.30	100.65	106.93
2	C	317	NAD	C1B-N9A-C4A	-4.12	119.41	126.64
2	D	317	NAD	N3A-C2A-N1A	-4.07	122.31	128.68
2	C	317	NAD	O4B-C1B-C2B	-4.03	101.04	106.93
2	A	317	NAD	C3N-C7N-N7N	4.03	122.58	117.75
2	A	317	NAD	O4B-C1B-C2B	-3.76	101.44	106.93

Continued on next page...

Continued from previous page...

Mol	Chain	Res	Type	Atoms	Z	Observed(°)	Ideal(°)
2	A	317	NAD	C6N-N1N-C2N	3.37	125.05	121.97
2	A	317	NAD	C4A-C5A-N7A	-3.32	105.94	109.40
2	B	317	NAD	C3N-C2N-N1N	-3.16	117.34	120.43
2	B	317	NAD	C5B-C4B-C3B	-3.05	103.76	115.18
2	B	317	NAD	N6A-C6A-N1A	2.96	124.72	118.57
2	B	317	NAD	C2A-N1A-C6A	2.84	123.62	118.75
2	B	317	NAD	N3A-C2A-N1A	-2.81	124.29	128.68
2	D	317	NAD	C2A-N1A-C6A	2.78	123.51	118.75
2	A	317	NAD	C5B-C4B-C3B	-2.76	104.84	115.18
2	D	317	NAD	C1B-N9A-C4A	-2.75	121.82	126.64
2	C	317	NAD	C5N-C4N-C3N	-2.71	117.14	120.34
2	C	317	NAD	C2N-C3N-C4N	2.68	121.30	118.26
2	B	317	NAD	C6N-N1N-C2N	2.68	124.42	121.97
2	C	317	NAD	N3A-C2A-N1A	-2.67	124.51	128.68
2	D	317	NAD	O4D-C1D-C2D	-2.66	103.04	106.93
2	C	317	NAD	O4D-C4D-C5D	-2.60	100.82	109.37
2	A	317	NAD	C1B-N9A-C4A	-2.57	122.13	126.64
2	A	317	NAD	O4D-C1D-C2D	-2.53	103.22	106.93
2	A	317	NAD	C2A-N1A-C6A	2.53	123.09	118.75
2	B	317	NAD	C4A-C5A-N7A	-2.53	106.76	109.40
2	D	317	NAD	O5D-PN-O1N	-2.52	99.22	109.07
2	C	317	NAD	C5A-C6A-N6A	2.47	124.11	120.35
2	C	317	NAD	PN-O3-PA	-2.36	124.74	132.83
2	A	317	NAD	O5D-PN-O1N	-2.32	99.98	109.07
2	D	317	NAD	O4D-C4D-C5D	-2.32	101.73	109.37
2	C	317	NAD	O3B-C3B-C2B	2.32	119.31	111.82
2	D	317	NAD	C5B-C4B-C3B	-2.24	106.79	115.18
2	B	317	NAD	O5D-PN-O1N	-2.20	100.48	109.07
2	C	317	NAD	O7N-C7N-C3N	-2.20	117.00	119.63
2	A	317	NAD	O5D-C5D-C4D	2.19	116.53	108.99
2	A	317	NAD	O7N-C7N-N7N	-2.16	119.50	122.58
2	D	317	NAD	PN-O3-PA	-2.15	125.45	132.83
2	C	317	NAD	C4A-C5A-N7A	-2.14	107.17	109.40
2	A	317	NAD	O4D-C4D-C5D	-2.13	102.36	109.37
2	A	317	NAD	PN-O3-PA	-2.11	125.59	132.83
2	B	317	NAD	O7N-C7N-N7N	-2.03	119.70	122.58

There are no chirality outliers.

All (24) torsion outliers are listed below:

Mol	Chain	Res	Type	Atoms
2	A	317	NAD	O4D-C1D-N1N-C2N

Continued on next page...

Continued from previous page...

Mol	Chain	Res	Type	Atoms
2	A	317	NAD	O4D-C1D-N1N-C6N
2	A	317	NAD	C2D-C1D-N1N-C2N
2	B	317	NAD	O4D-C1D-N1N-C2N
2	B	317	NAD	O4D-C1D-N1N-C6N
2	B	317	NAD	C2D-C1D-N1N-C2N
2	C	317	NAD	O4D-C1D-N1N-C2N
2	C	317	NAD	O4D-C1D-N1N-C6N
2	C	317	NAD	C2D-C1D-N1N-C2N
2	D	317	NAD	O4D-C1D-N1N-C2N
2	D	317	NAD	O4D-C1D-N1N-C6N
2	D	317	NAD	C2D-C1D-N1N-C2N
2	D	317	NAD	C2D-C1D-N1N-C6N
2	A	317	NAD	PA-O3-PN-O2N
2	D	317	NAD	O4B-C4B-C5B-O5B
2	C	317	NAD	C5D-O5D-PN-O3
2	D	317	NAD	C5D-O5D-PN-O3
2	B	317	NAD	O4B-C4B-C5B-O5B
2	C	317	NAD	O4B-C4B-C5B-O5B
2	B	317	NAD	PA-O3-PN-O1N
2	B	317	NAD	PA-O3-PN-O2N
2	C	317	NAD	PA-O3-PN-O2N
2	D	317	NAD	PA-O3-PN-O2N
2	A	317	NAD	O4B-C4B-C5B-O5B

There are no ring outliers.

No monomer is involved in short contacts.

The following is a two-dimensional graphical depiction of Mogul quality analysis of bond lengths, bond angles, torsion angles, and ring geometry for all instances of the Ligand of Interest. In addition, ligands with molecular weight > 250 and outliers as shown on the validation Tables will also be included. For torsion angles, if less than 5% of the Mogul distribution of torsion angles is within 10 degrees of the torsion angle in question, then that torsion angle is considered an outlier. Any bond that is central to one or more torsion angles identified as an outlier by Mogul will be highlighted in the graph. For rings, the root-mean-square deviation (RMSD) between the ring in question and similar rings identified by Mogul is calculated over all ring torsion angles. If the average RMSD is greater than 60 degrees and the minimal RMSD between the ring in question and any Mogul-identified rings is also greater than 60 degrees, then that ring is considered an outlier. The outliers are highlighted in purple. The color gray indicates Mogul did not find sufficient equivalents in the CSD to analyse the geometry.

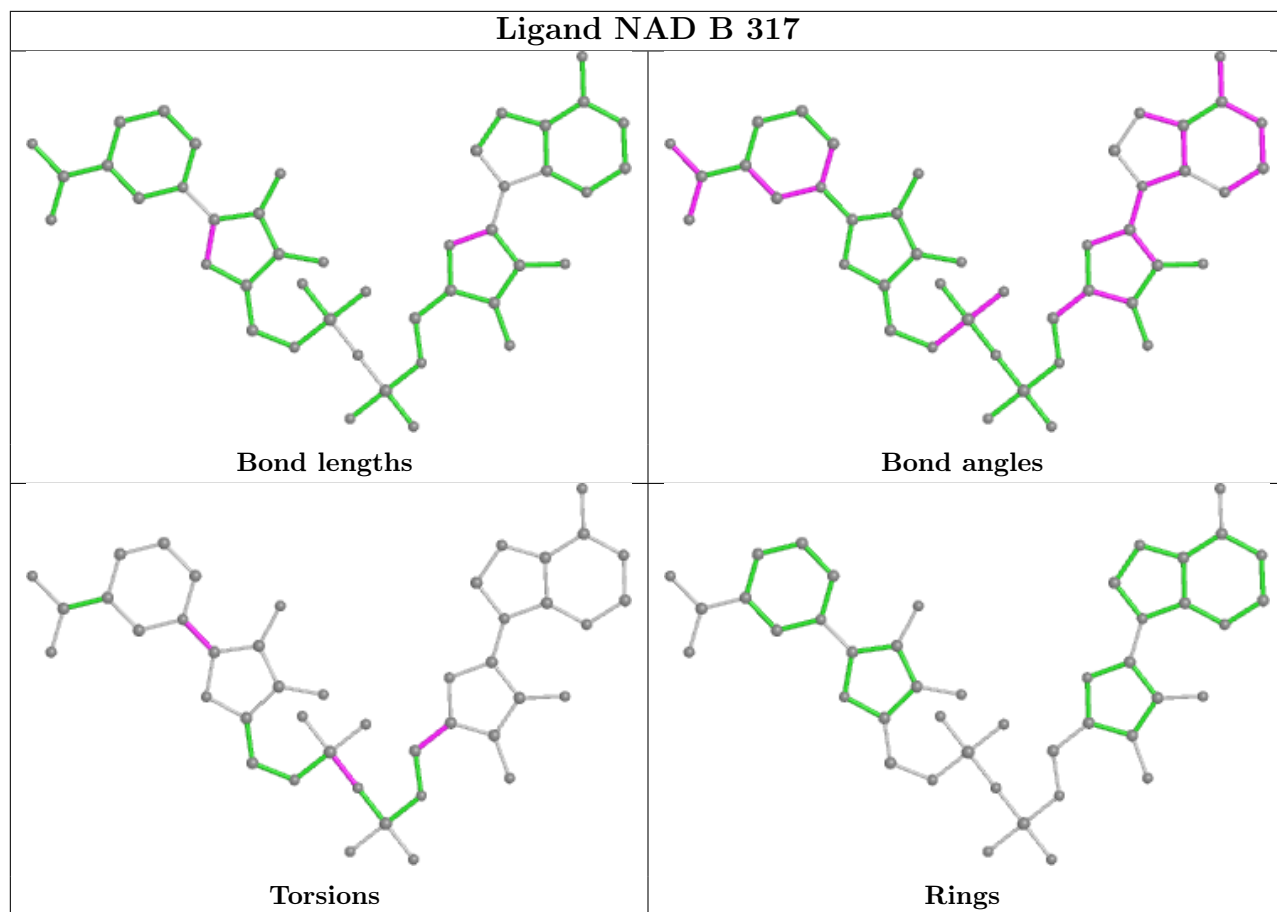

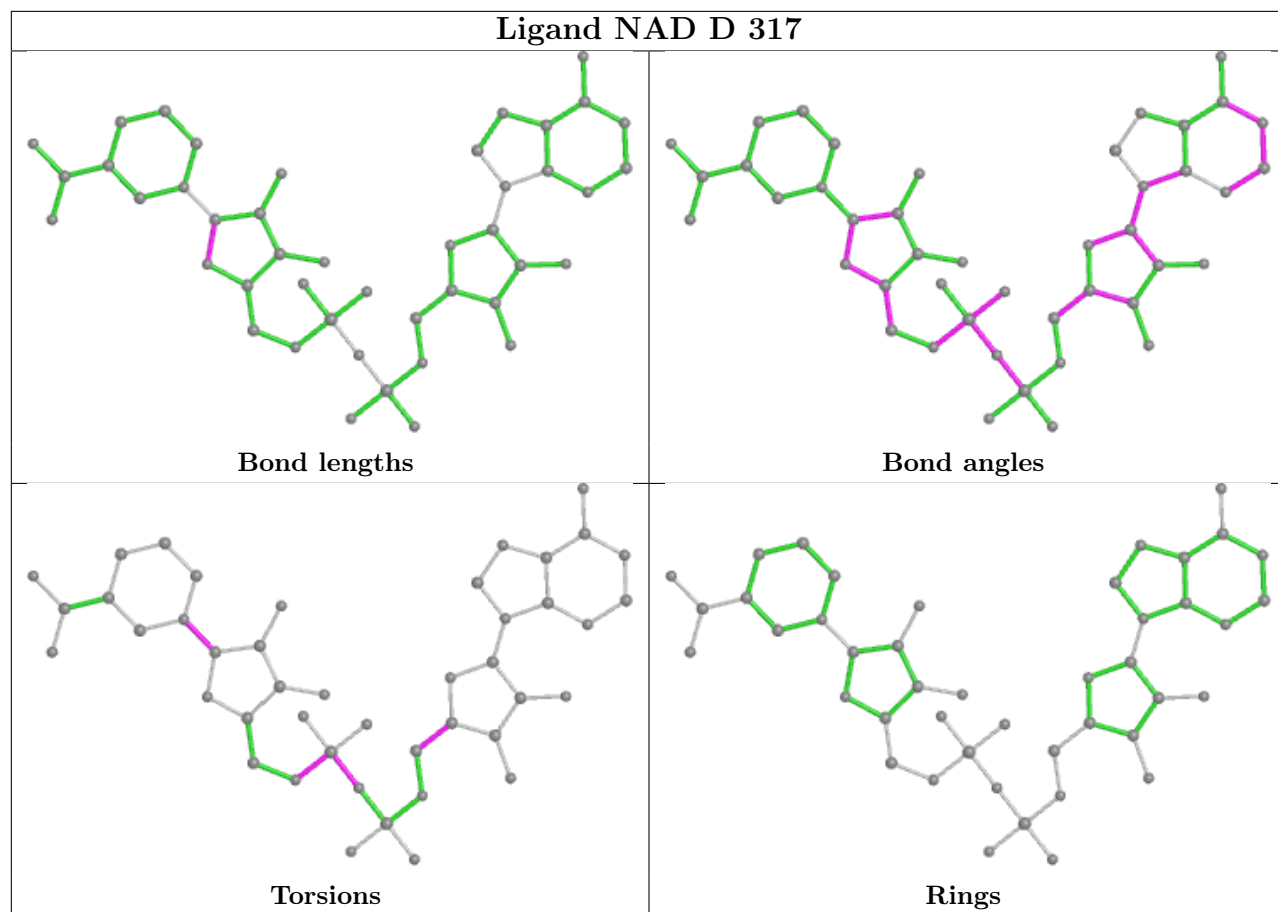

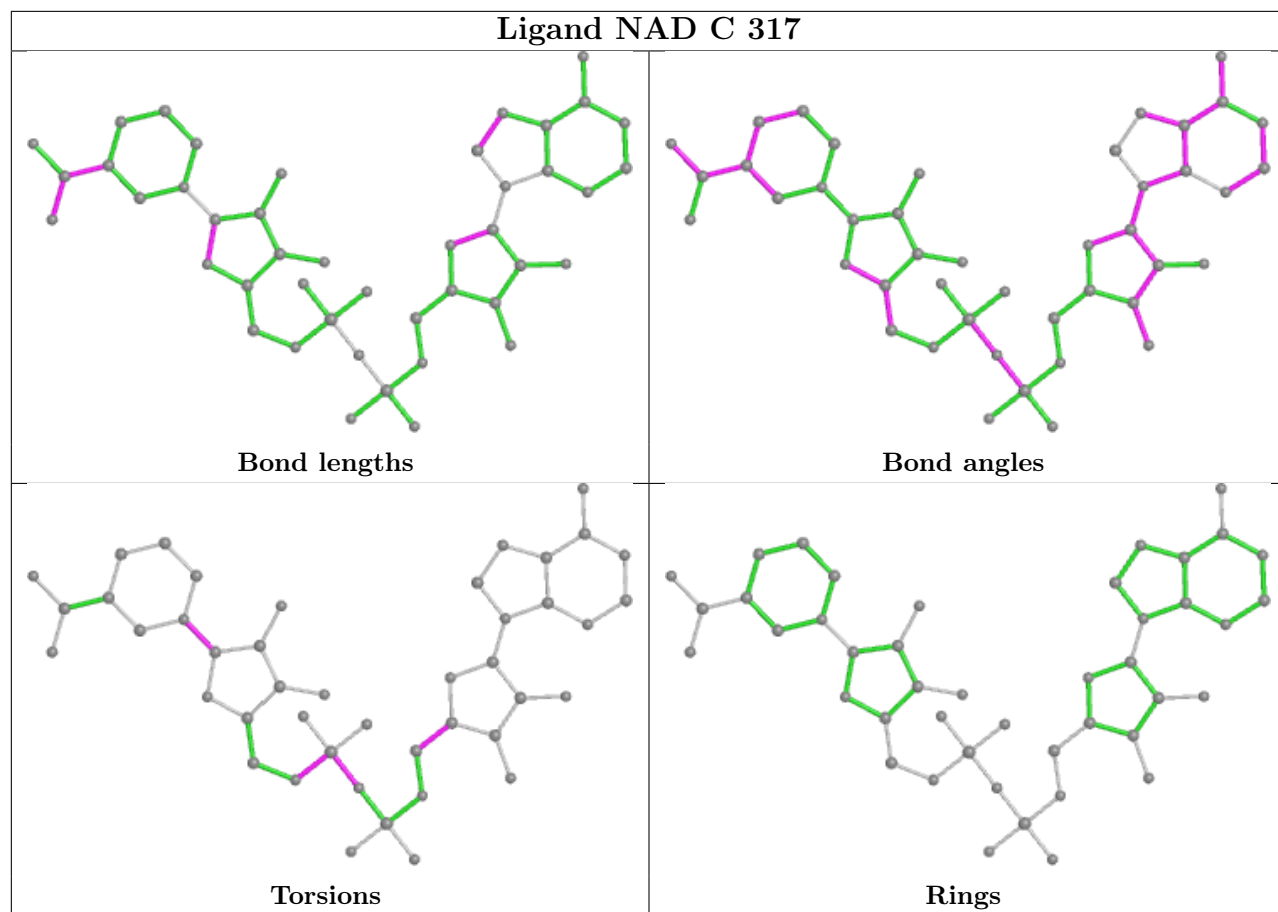

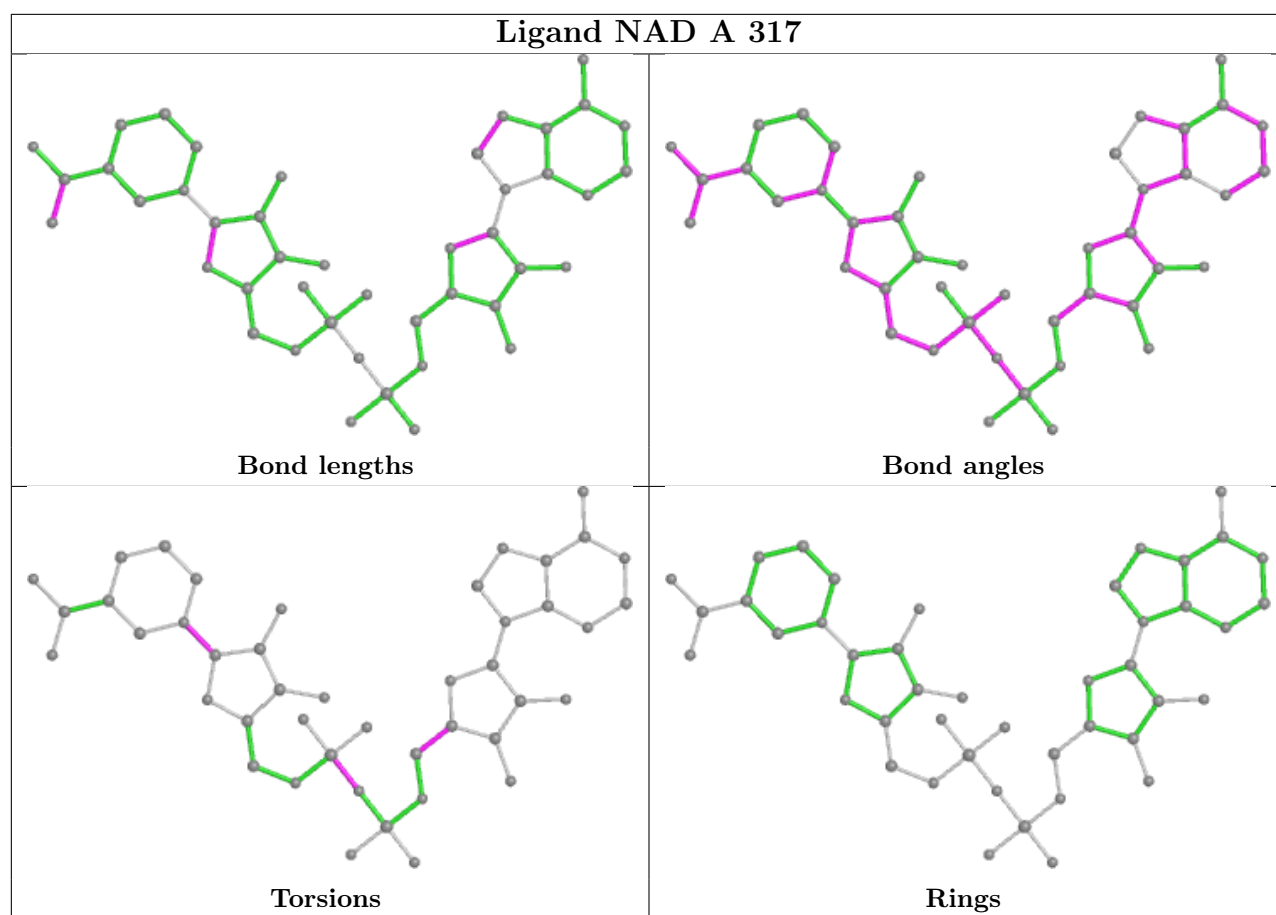

5.7 Other polymers [i](#)

There are no such residues in this entry.

5.8 Polymer linkage issues [i](#)

There are no chain breaks in this entry.

6 Fit of model and data

6.1 Protein, DNA and RNA chains

In the following table, the column labelled ‘#RSRZ > 2’ contains the number (and percentage) of RSRZ outliers, followed by percent RSRZ outliers for the chain as percentile scores relative to all X-ray entries and entries of similar resolution. The OWAB column contains the minimum, median, 95th percentile and maximum values of the occupancy-weighted average B-factor per residue. The column labelled ‘Q < 0.9’ lists the number of (and percentage) of residues with an average occupancy less than 0.9.

Mol	Chain	Analysed	<RSRZ>	#RSRZ>2	OWAB(Å ²)	Q<0.9
1	A	306/318 (96%)	0.13	22 (7%) 15 16	10, 19, 38, 53	0
1	B	311/318 (97%)	0.10	20 (6%) 19 20	10, 20, 63, 156	0
1	C	299/318 (94%)	0.11	17 (5%) 23 25	11, 20, 70, 130	0
1	D	298/318 (93%)	0.56	42 (14%) 2 2	10, 28, 105, 160	0
All	All	1214/1272 (95%)	0.22	101 (8%) 11 12	10, 21, 74, 160	0

All (101) RSRZ outliers are listed below:

Mol	Chain	Res	Type	RSRZ
1	A	258	PHE	9.7
1	B	239	VAL	6.6
1	D	135	GLN	6.0
1	A	150	PRO	5.8
1	D	143	LYS	5.1
1	A	264	ASP	4.9
1	A	238	SER	4.9
1	D	137	ILE	4.8
1	D	239	VAL	4.8
1	D	145	ALA	4.8
1	D	254	GLU	4.6
1	A	146	ARG	4.5
1	D	303	SER	4.5
1	B	258	PHE	4.5
1	D	157	LEU	4.5
1	D	304	ASP	4.3
1	A	312	ALA	4.3
1	D	305	ASN	4.0
1	D	302	ALA	3.9
1	C	311	VAL	3.9
1	B	241	GLY	3.9

Continued on next page...

Continued from previous page...

Mol	Chain	Res	Type	RSRZ
1	A	135	GLN	3.8
1	A	145	ALA	3.8
1	D	196	ILE	3.8
1	D	264	ASP	3.7
1	A	147	GLU	3.6
1	A	239	VAL	3.6
1	D	301	PRO	3.5
1	D	138	ILE	3.4
1	A	241	GLY	3.4
1	B	150	PRO	3.4
1	A	151	HIS	3.2
1	C	236	PRO	3.2
1	C	244	PRO	3.2
1	A	257	GLU	3.2
1	D	154	GLU	3.2
1	C	233	ASN	3.2
1	D	139	ALA	3.1
1	B	148	LYS	3.1
1	B	237	GLU	3.1
1	A	149	SER	3.0
1	D	141	LYS	3.0
1	D	299	ILE	3.0
1	B	315	ALA	3.0
1	B	238	SER	3.0
1	A	242	LYS	3.0
1	B	242	LYS	3.0
1	C	245	THR	3.0
1	D	144	VAL	2.9
1	B	149	SER	2.9
1	A	237	GLU	2.9
1	D	249	ILE	2.9
1	D	223	ARG	2.9
1	B	243	LYS	2.8
1	C	232	ALA	2.8
1	D	155	VAL	2.8
1	C	150	PRO	2.8
1	D	140	LEU	2.7
1	D	134	HIS	2.7
1	D	222	ALA	2.7
1	A	142	ASP	2.7
1	A	143	LYS	2.6
1	B	211	TYR	2.6

Continued on next page...

Continued from previous page...

Mol	Chain	Res	Type	RSRZ
1	D	153	TYR	2.6
1	D	77	ILE	2.6
1	B	264	ASP	2.6
1	C	162	SER	2.6
1	D	306	GLU	2.6
1	A	304	ASP	2.6
1	C	231	ASP	2.6
1	C	148	LYS	2.5
1	D	246	TYR	2.5
1	C	301	PRO	2.5
1	D	238	SER	2.4
1	C	246	TYR	2.4
1	D	237	GLU	2.4
1	B	240	LYS	2.4
1	D	310	PHE	2.3
1	D	198	GLY	2.3
1	C	258	PHE	2.3
1	D	233	ASN	2.3
1	C	254	GLU	2.3
1	D	189	PHE	2.3
1	B	316	ARG	2.2
1	D	252	ASN	2.2
1	B	246	TYR	2.2
1	D	190	TYR	2.2
1	D	221	GLN	2.2
1	D	255	GLU	2.2
1	C	226	TRP	2.2
1	D	253	GLY	2.1
1	B	236	PRO	2.1
1	C	207	PHE	2.1
1	D	185	ILE	2.1
1	C	1	MET	2.1
1	B	68	SER	2.1
1	A	305	ASN	2.1
1	A	185	ILE	2.0
1	B	77	ILE	2.0
1	B	146	ARG	2.0
1	A	303	SER	2.0

6.2 Non-standard residues in protein, DNA, RNA chains

There are no non-standard protein/DNA/RNA residues in this entry.

6.3 Carbohydrates [i](#)

There are no monosaccharides in this entry.

6.4 Ligands [i](#)

In the following table, the Atoms column lists the number of modelled atoms in the group and the number defined in the chemical component dictionary. The B-factors column lists the minimum, median, 95th percentile and maximum values of B factors of atoms in the group. The column labelled 'Q < 0.9' lists the number of atoms with occupancy less than 0.9.

Mol	Type	Chain	Res	Atoms	RSCC	RSR	B-factors(Å ²)	Q<0.9
2	NAD	A	317	44/44	0.98	0.08	7,12,22,27	0
2	NAD	B	317	44/44	0.98	0.07	7,11,16,22	0
2	NAD	C	317	44/44	0.98	0.07	9,12,18,20	0
2	NAD	D	317	44/44	0.98	0.08	9,13,26,39	0

The following is a graphical depiction of the model fit to experimental electron density of all instances of the Ligand of Interest. In addition, ligands with molecular weight > 250 and outliers as shown on the geometry validation Tables will also be included. Each fit is shown from different orientation to approximate a three-dimensional view.

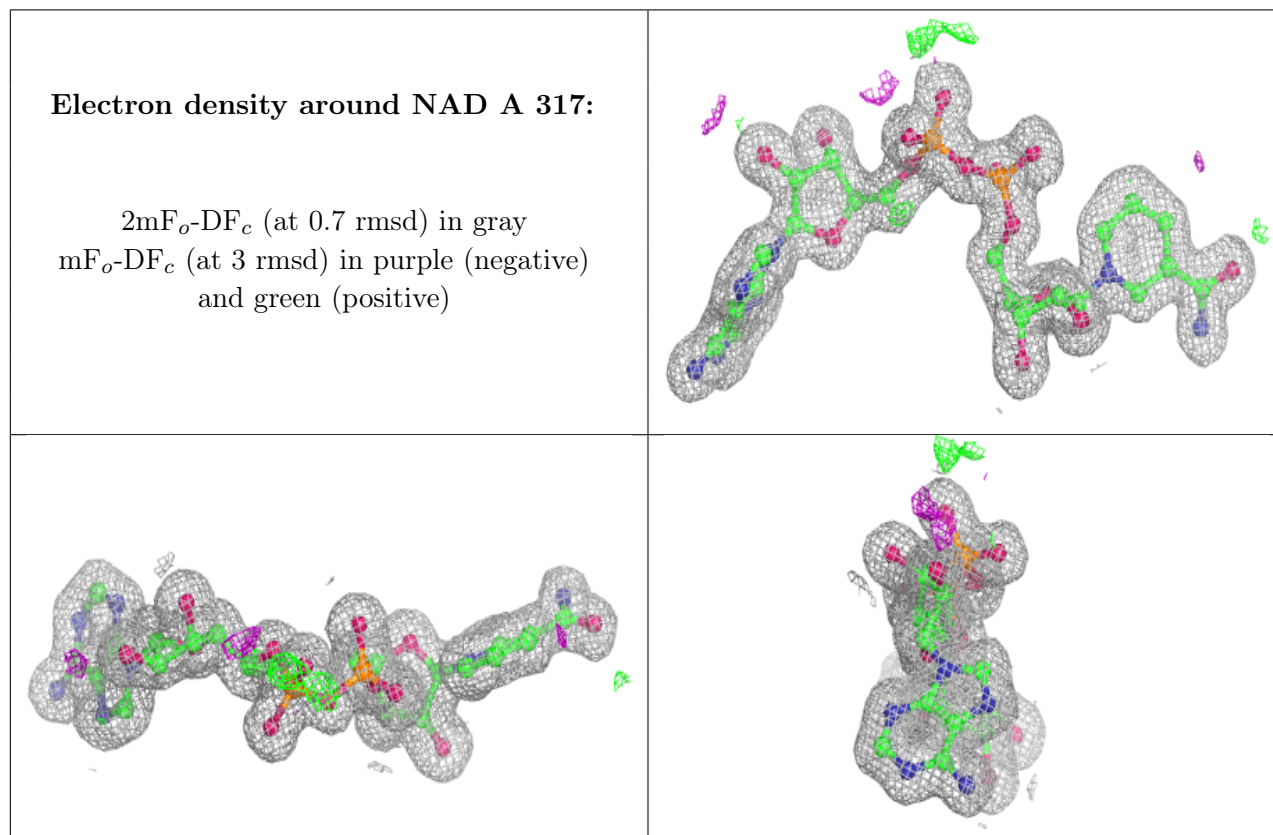

Electron density around NAD B 317:

$2mF_o-DF_c$ (at 0.7 rmsd) in gray
 mF_o-DF_c (at 3 rmsd) in purple (negative)
and green (positive)

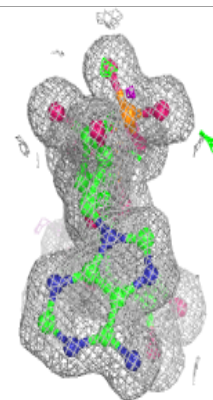
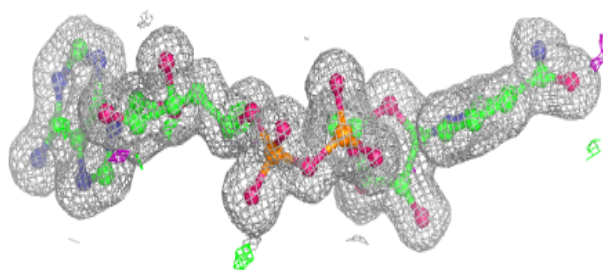
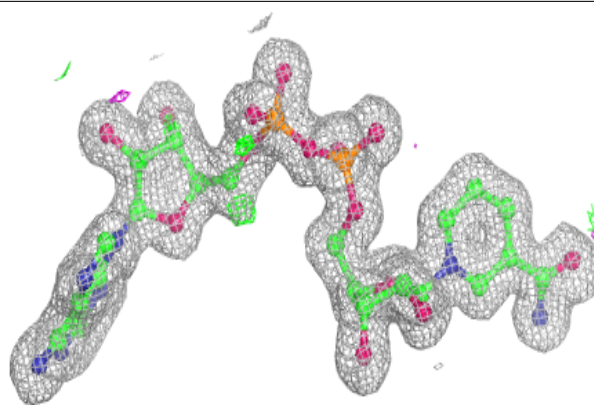
**Electron density around NAD C 317:**

$2mF_o-DF_c$ (at 0.7 rmsd) in gray
 mF_o-DF_c (at 3 rmsd) in purple (negative)
and green (positive)

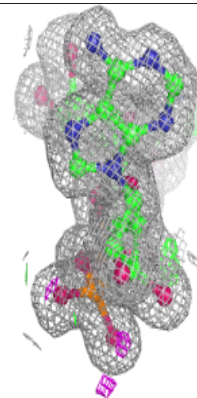
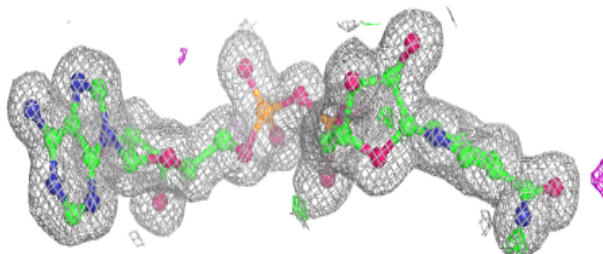
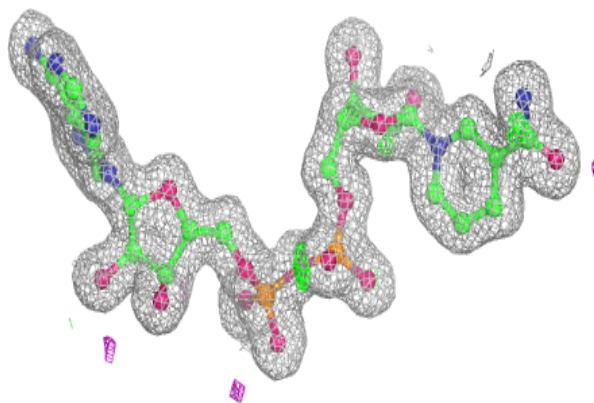

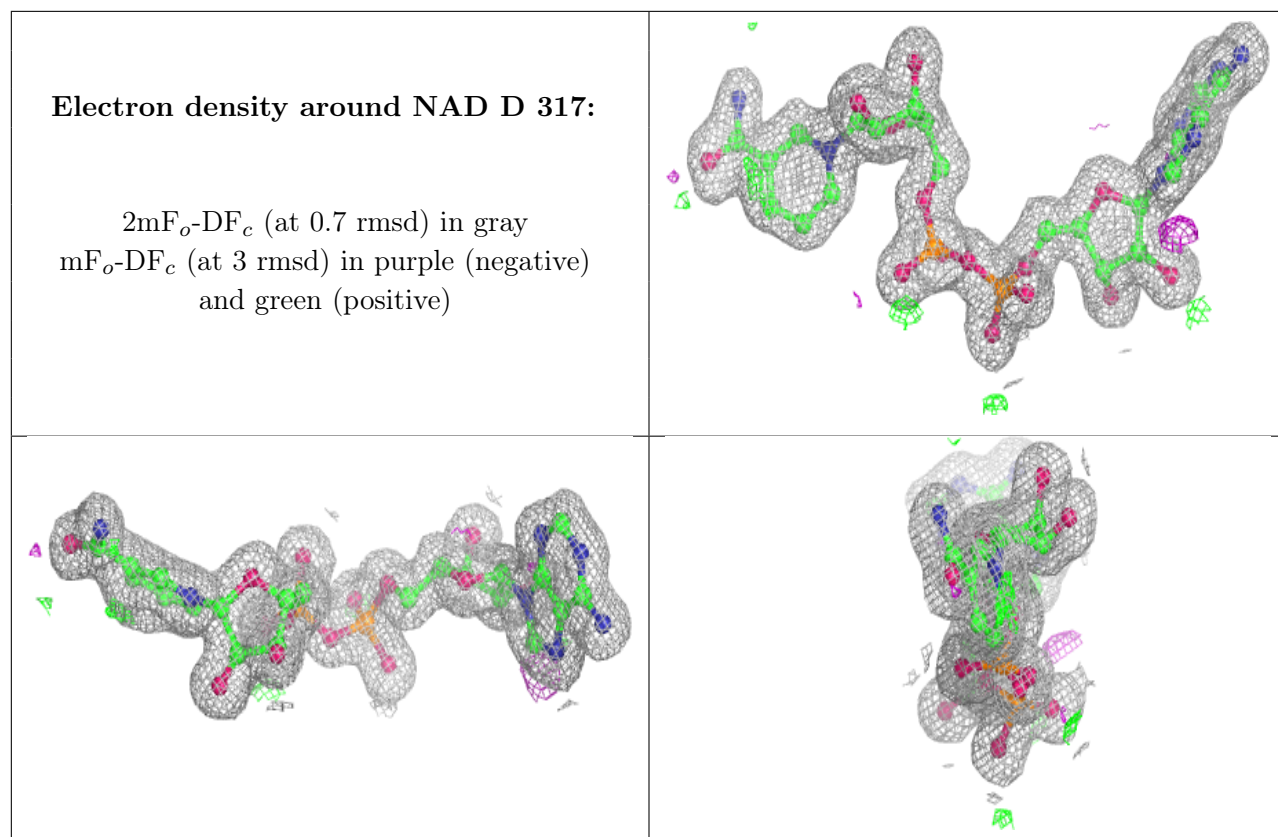

6.5 Other polymers [i](#)

There are no such residues in this entry.