



wwPDB EM Validation Summary Report ⓘ

Mar 9, 2024 – 02:37 PM EST

PDB ID : 6O2S
EMDB ID : EMD-0614
Title : Deacetylated Microtubules
Authors : Eshun-Wilson, L.; Zhang, R.; Portran, D.; Nachury, M.V.; Toso, D.; Lohr, T.; Vendruscolo, M.; Bonomi, M.; Fraser, J.S.; Nogales, E.
Deposited on : 2019-02-24
Resolution : 4.00 Å(reported)
Based on initial model : 3JAR

This is a wwPDB EM Validation Summary Report for a publicly released PDB entry.

We welcome your comments at validation@mail.wwpdb.org

A user guide is available at

<https://www.wwpdb.org/validation/2017/EMValidationReportHelp>

with specific help available everywhere you see the ⓘ symbol.

The types of validation reports are described at

<http://www.wwpdb.org/validation/2017/FAQs#types>.

The following versions of software and data (see [references ⓘ](#)) were used in the production of this report:

EMDB validation analysis : 0.0.1.dev70
Mogul : 1.8.5 (274361), CSD as541be (2020)
MolProbity : 4.02b-467
buster-report : 1.1.7 (2018)
Percentile statistics : 20191225.v01 (using entries in the PDB archive December 25th 2019)
MapQ : 1.9.13
Ideal geometry (proteins) : Engh & Huber (2001)
Ideal geometry (DNA, RNA) : Parkinson et al. (1996)
Validation Pipeline (wwPDB-VP) : 2.36

1 Overall quality at a glance

The following experimental techniques were used to determine the structure:

ELECTRON MICROSCOPY

The reported resolution of this entry is 4.00 Å.

Percentile scores (ranging between 0-100) for global validation metrics of the entry are shown in the following graphic. The table shows the number of entries on which the scores are based.

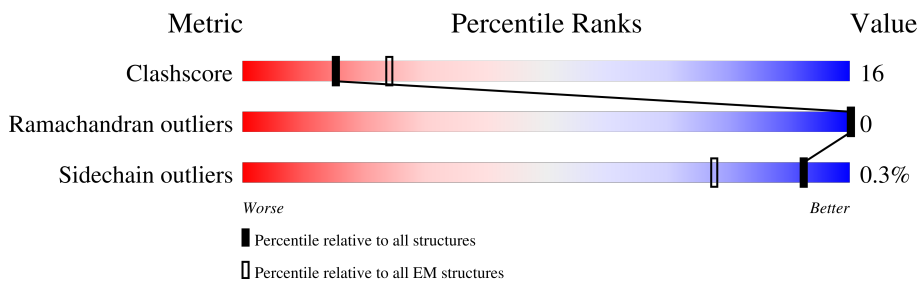

Metric	Whole archive (#Entries)	EM structures (#Entries)
Clashscore	158937	4297
Ramachandran outliers	154571	4023
Sidechain outliers	154315	3826

The table below summarises the geometric issues observed across the polymeric chains and their fit to the map. The red, orange, yellow and green segments of the bar indicate the fraction of residues that contain outliers for ≥ 3 , 2, 1 and 0 types of geometric quality criteria respectively. A grey segment represents the fraction of residues that are not modelled. The numeric value for each fraction is indicated below the corresponding segment, with a dot representing fractions $\leq 5\%$. The upper red bar (where present) indicates the fraction of residues that have poor fit to the EM map (all-atom inclusion $< 40\%$). The numeric value is given above the bar.

Mol	Chain	Length	Quality of chain
1	1A	451	
1	1B	451	
1	1C	451	
1	1D	451	
1	1E	451	
1	1F	451	
1	1G	451	
1	1I	451	

Continued on next page...

Continued from previous page...

Mol	Chain	Length	Quality of chain
1	1J	451	30% 73% 23%
1	1K	451	37% 73% 23%
1	1L	451	35% 75% 21%
1	1M	451	85% 75% 22%
1	1N	451	27% 75% 22%
1	2A	451	22% 77% 19%
1	2B	451	17% 77% 19%
1	2C	451	17% 77% 19%
1	2D	451	18% 77% 19%
1	2E	451	15% 77% 19%
1	2F	451	21% 76% 20%
1	2G	451	21% 77% 19%
1	2I	451	22% 75% 21%
1	2J	451	21% 75% 21%
1	2K	451	18% 75% 21%
1	2L	451	19% 76% 20%
1	2M	451	20% 76% 20%
1	2N	451	34% 76% 20%
1	3A	451	35% 74% 22%
1	3B	451	34% 74% 22%
1	3C	451	32% 74% 22%
1	3D	451	28% 74% 22%
1	3E	451	29% 75% 21%
1	3F	451	31% 75% 22%
1	3G	451	33% 75% 21%

Continued on next page...

Continued from previous page...

Mol	Chain	Length	Quality of chain
1	3I	451	34% 74% 22%
1	3J	451	30% 75% 22%
1	3K	451	28% 74% 22%
1	3L	451	30% 75% 21%
1	3M	451	40% 75% 22%
1	3N	451	54% 75% 21%
1	4A	451	51% 80% 16%
1	4B	451	43% 80% 16%
1	4C	451	44% 80% 16%
1	4D	451	46% 80% 16%
1	4E	451	43% 80% 16%
1	4F	451	42% 80% 16%
1	4G	451	41% 80% 16%
1	4I	451	45% 80% 17%
1	4J	451	45% 80% 17%
1	4K	451	47% 79% 17%
1	4L	451	79% 80% 16%
1	4M	451	92% 80% 16%
1	4N	451	58% 81% 15%
2	1H	445	17% 73% 23%
2	1O	445	18% 74% 22%
2	1P	445	17% 74% 22%
2	1Q	445	17% 74% 22%
2	1R	445	24% 73% 23%
2	1S	445	30% 73% 24%

Continued on next page...

Continued from previous page...

Mol	Chain	Length	Quality of chain
2	1T	445	31% 73% 23%
2	1U	445	36% 73% 24%
2	1V	445	36% 73% 24%
2	1W	445	44% 72% 25%
2	1X	445	49% 72% 24%
2	1Y	445	62% 73% 23%
2	1Z	445	25% 73% 23%
2	2H	445	29% 71% 26%
2	2O	445	26% 71% 25%
2	2P	445	25% 71% 26%
2	2Q	445	23% 70% 26%
2	2R	445	24% 70% 26%
2	2S	445	23% 71% 26%
2	2T	445	23% 71% 25%
2	2U	445	24% 71% 25%
2	2V	445	23% 71% 25%
2	2W	445	21% 70% 26%
2	2X	445	28% 70% 26%
2	2Y	445	36% 72% 25%
2	2Z	445	37% 72% 25%
2	3H	445	72% 77% 20%
2	3O	445	65% 77% 20%
2	3P	445	51% 76% 20%
2	3Q	445	39% 77% 20%
2	3R	445	33% 77% 20%

Continued on next page...

Continued from previous page...

Mol	Chain	Length	Quality of chain
2	3S	445	36% 76% 20%
2	3T	445	34% 77% 20%
2	3U	445	31% 76% 20%
2	3V	445	33% 76% 20%
2	3W	445	32% 76% 21%
2	3X	445	44% 76% 20%
2	3Y	445	52% 77% 20%
2	3Z	445	87% 77% 19%
2	4H	445	32% 70% 26%
2	4O	445	31% 71% 26%
2	4P	445	32% 69% 27%
2	4Q	445	36% 69% 27%
2	4R	445	33% 69% 27%
2	4S	445	31% 69% 27%
2	4T	445	32% 69% 27%
2	4U	445	33% 69% 27%
2	4V	445	28% 70% 27%
2	4W	445	27% 70% 27%
2	4X	445	42% 69% 27%
2	4Y	445	91% 71% 25%
2	4Z	445	38% 71% 25%

2 Entry composition [i](#)

There are 5 unique types of molecules in this entry. The entry contains 354900 atoms, of which 0 are hydrogens and 0 are deuteriums.

In the tables below, the AltConf column contains the number of residues with at least one atom in alternate conformation and the Trace column contains the number of residues modelled with at most 2 atoms.

- Molecule 1 is a protein called Tubulin alpha-1B chain.

Mol	Chain	Residues	Atoms					AltConf	Trace
			Total	C	N	O	S		
1	1A	434	3396	2151	577	647	21	0	0
1	1B	434	3396	2151	577	647	21	0	0
1	1C	434	3396	2151	577	647	21	0	0
1	1D	434	3396	2151	577	647	21	0	0
1	1E	434	3396	2151	577	647	21	0	0
1	1F	434	3396	2151	577	647	21	0	0
1	1G	434	3396	2151	577	647	21	0	0
1	1I	434	3396	2151	577	647	21	0	0
1	1J	434	3396	2151	577	647	21	0	0
1	1K	434	3396	2151	577	647	21	0	0
1	1L	434	3396	2151	577	647	21	0	0
1	1M	434	3396	2151	577	647	21	0	0
1	1N	434	3396	2151	577	647	21	0	0
1	2A	434	3396	2151	577	647	21	0	0
1	2B	434	3396	2151	577	647	21	0	0
1	2C	434	3396	2151	577	647	21	0	0
1	2D	434	3396	2151	577	647	21	0	0

Continued on next page...

Continued from previous page...

Mol	Chain	Residues	Atoms					AltConf	Trace
1	2E	434	Total 3396	C 2151	N 577	O 647	S 21	0	0
1	2F	434	Total 3396	C 2151	N 577	O 647	S 21	0	0
1	2G	434	Total 3396	C 2151	N 577	O 647	S 21	0	0
1	2I	434	Total 3396	C 2151	N 577	O 647	S 21	0	0
1	2J	434	Total 3396	C 2151	N 577	O 647	S 21	0	0
1	2K	434	Total 3396	C 2151	N 577	O 647	S 21	0	0
1	2L	434	Total 3396	C 2151	N 577	O 647	S 21	0	0
1	2M	434	Total 3396	C 2151	N 577	O 647	S 21	0	0
1	2N	434	Total 3396	C 2151	N 577	O 647	S 21	0	0
1	3A	434	Total 3396	C 2151	N 577	O 647	S 21	0	0
1	3B	434	Total 3396	C 2151	N 577	O 647	S 21	0	0
1	3C	434	Total 3396	C 2151	N 577	O 647	S 21	0	0
1	3D	434	Total 3396	C 2151	N 577	O 647	S 21	0	0
1	3E	434	Total 3396	C 2151	N 577	O 647	S 21	0	0
1	3F	434	Total 3396	C 2151	N 577	O 647	S 21	0	0
1	3G	434	Total 3396	C 2151	N 577	O 647	S 21	0	0
1	3I	434	Total 3396	C 2151	N 577	O 647	S 21	0	0
1	3J	434	Total 3396	C 2151	N 577	O 647	S 21	0	0
1	3K	434	Total 3396	C 2151	N 577	O 647	S 21	0	0
1	3L	434	Total 3396	C 2151	N 577	O 647	S 21	0	0
1	3M	434	Total 3396	C 2151	N 577	O 647	S 21	0	0

Continued on next page...

Continued from previous page...

Mol	Chain	Residues	Atoms					AltConf	Trace
1	3N	434	Total	C	N	O	S	0	0
			3396	2151	577	647	21		
1	4A	434	Total	C	N	O	S	0	0
			3396	2151	577	647	21		
1	4B	434	Total	C	N	O	S	0	0
			3396	2151	577	647	21		
1	4C	434	Total	C	N	O	S	0	0
			3396	2151	577	647	21		
1	4D	434	Total	C	N	O	S	0	0
			3396	2151	577	647	21		
1	4E	434	Total	C	N	O	S	0	0
			3396	2151	577	647	21		
1	4F	434	Total	C	N	O	S	0	0
			3396	2151	577	647	21		
1	4G	434	Total	C	N	O	S	0	0
			3396	2151	577	647	21		
1	4I	434	Total	C	N	O	S	0	0
			3396	2151	577	647	21		
1	4J	434	Total	C	N	O	S	0	0
			3396	2151	577	647	21		
1	4K	434	Total	C	N	O	S	0	0
			3396	2151	577	647	21		
1	4L	434	Total	C	N	O	S	0	0
			3396	2151	577	647	21		
1	4M	434	Total	C	N	O	S	0	0
			3396	2151	577	647	21		
1	4N	434	Total	C	N	O	S	0	0
			3396	2151	577	647	21		

- Molecule 2 is a protein called Tubulin beta chain.

Mol	Chain	Residues	Atoms					AltConf	Trace
2	1H	429	Total	C	N	O	S	0	0
			3368	2115	578	650	25		
2	1O	429	Total	C	N	O	S	0	0
			3368	2115	578	650	25		
2	1P	429	Total	C	N	O	S	0	0
			3368	2115	578	650	25		
2	1Q	429	Total	C	N	O	S	0	0
			3368	2115	578	650	25		
2	1R	429	Total	C	N	O	S	0	0
			3368	2115	578	650	25		

Continued on next page...

Continued from previous page...

Mol	Chain	Residues	Atoms					AltConf	Trace
			Total	C	N	O	S		
2	1S	429	Total 3368	C 2115	N 578	O 650	S 25	0	0
2	1T	429	Total 3368	C 2115	N 578	O 650	S 25	0	0
2	1U	429	Total 3368	C 2115	N 578	O 650	S 25	0	0
2	1V	429	Total 3368	C 2115	N 578	O 650	S 25	0	0
2	1W	429	Total 3368	C 2115	N 578	O 650	S 25	0	0
2	1X	429	Total 3368	C 2115	N 578	O 650	S 25	0	0
2	1Y	429	Total 3368	C 2115	N 578	O 650	S 25	0	0
2	1Z	429	Total 3368	C 2115	N 578	O 650	S 25	0	0
2	2H	429	Total 3368	C 2115	N 578	O 650	S 25	0	0
2	2O	429	Total 3368	C 2115	N 578	O 650	S 25	0	0
2	2P	429	Total 3368	C 2115	N 578	O 650	S 25	0	0
2	2Q	429	Total 3368	C 2115	N 578	O 650	S 25	0	0
2	2R	429	Total 3368	C 2115	N 578	O 650	S 25	0	0
2	2S	429	Total 3368	C 2115	N 578	O 650	S 25	0	0
2	2T	429	Total 3368	C 2115	N 578	O 650	S 25	0	0
2	2U	429	Total 3368	C 2115	N 578	O 650	S 25	0	0
2	2V	429	Total 3368	C 2115	N 578	O 650	S 25	0	0
2	2W	429	Total 3368	C 2115	N 578	O 650	S 25	0	0
2	2X	429	Total 3368	C 2115	N 578	O 650	S 25	0	0
2	2Y	429	Total 3368	C 2115	N 578	O 650	S 25	0	0
2	2Z	429	Total 3368	C 2115	N 578	O 650	S 25	0	0

Continued on next page...

Continued from previous page...

Mol	Chain	Residues	Atoms					AltConf	Trace
2	3H	429	Total 3368	C 2115	N 578	O 650	S 25	0	0
2	3O	429	Total 3368	C 2115	N 578	O 650	S 25	0	0
2	3P	429	Total 3368	C 2115	N 578	O 650	S 25	0	0
2	3Q	429	Total 3368	C 2115	N 578	O 650	S 25	0	0
2	3R	429	Total 3368	C 2115	N 578	O 650	S 25	0	0
2	3S	429	Total 3368	C 2115	N 578	O 650	S 25	0	0
2	3T	429	Total 3368	C 2115	N 578	O 650	S 25	0	0
2	3U	429	Total 3368	C 2115	N 578	O 650	S 25	0	0
2	3V	429	Total 3368	C 2115	N 578	O 650	S 25	0	0
2	3W	429	Total 3368	C 2115	N 578	O 650	S 25	0	0
2	3X	429	Total 3368	C 2115	N 578	O 650	S 25	0	0
2	3Y	429	Total 3368	C 2115	N 578	O 650	S 25	0	0
2	3Z	429	Total 3368	C 2115	N 578	O 650	S 25	0	0
2	4H	429	Total 3368	C 2115	N 578	O 650	S 25	0	0
2	4O	429	Total 3368	C 2115	N 578	O 650	S 25	0	0
2	4P	429	Total 3368	C 2115	N 578	O 650	S 25	0	0
2	4Q	429	Total 3368	C 2115	N 578	O 650	S 25	0	0
2	4R	429	Total 3368	C 2115	N 578	O 650	S 25	0	0
2	4S	429	Total 3368	C 2115	N 578	O 650	S 25	0	0
2	4T	429	Total 3368	C 2115	N 578	O 650	S 25	0	0
2	4U	429	Total 3368	C 2115	N 578	O 650	S 25	0	0

Continued on next page...

Continued from previous page...

Mol	Chain	Residues	Atoms					AltConf	Trace
			Total	C	N	O	S		
2	4V	429	Total 3368	C 2115	N 578	O 650	S 25	0	0
2	4W	429	Total 3368	C 2115	N 578	O 650	S 25	0	0
2	4X	429	Total 3368	C 2115	N 578	O 650	S 25	0	0
2	4Y	429	Total 3368	C 2115	N 578	O 650	S 25	0	0
2	4Z	429	Total 3368	C 2115	N 578	O 650	S 25	0	0

- Molecule 3 is GUANOSINE-5'-TRIPHOSPHATE (three-letter code: GTP) (formula: $C_{10}H_{16}N_5O_{14}P_3$).

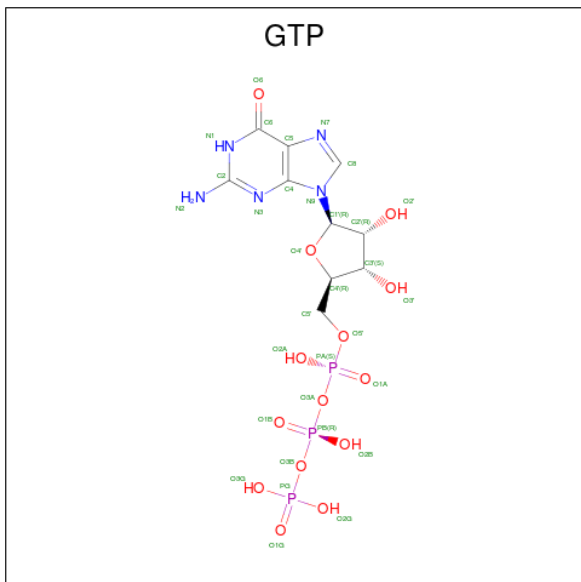

Mol	Chain	Residues	Atoms					AltConf
			Total	C	N	O	P	
3	1A	1	Total 32	C 10	N 5	O 14	P 3	0
3	1B	1	Total 32	C 10	N 5	O 14	P 3	0
3	1C	1	Total 32	C 10	N 5	O 14	P 3	0
3	1D	1	Total 32	C 10	N 5	O 14	P 3	0
3	1E	1	Total 32	C 10	N 5	O 14	P 3	0
3	1F	1	Total 32	C 10	N 5	O 14	P 3	0

Continued on next page...

Continued from previous page...

Mol	Chain	Residues	Atoms				AltConf	
			Total	C	N	O		P
3	1G	1	32	10	5	14	3	0
3	1I	1	32	10	5	14	3	0
3	1J	1	32	10	5	14	3	0
3	1K	1	32	10	5	14	3	0
3	1L	1	32	10	5	14	3	0
3	1M	1	32	10	5	14	3	0
3	1N	1	32	10	5	14	3	0
3	2A	1	32	10	5	14	3	0
3	2B	1	32	10	5	14	3	0
3	2C	1	32	10	5	14	3	0
3	2D	1	32	10	5	14	3	0
3	2E	1	32	10	5	14	3	0
3	2F	1	32	10	5	14	3	0
3	2G	1	32	10	5	14	3	0
3	2I	1	32	10	5	14	3	0
3	2J	1	32	10	5	14	3	0
3	2K	1	32	10	5	14	3	0
3	2L	1	32	10	5	14	3	0
3	2M	1	32	10	5	14	3	0
3	2N	1	32	10	5	14	3	0
3	3A	1	32	10	5	14	3	0

Continued on next page...

Continued from previous page...

Mol	Chain	Residues	Atoms					AltConf
			Total	C	N	O	P	
3	3B	1	Total 32	C 10	N 5	O 14	P 3	0
3	3C	1	Total 32	C 10	N 5	O 14	P 3	0
3	3D	1	Total 32	C 10	N 5	O 14	P 3	0
3	3E	1	Total 32	C 10	N 5	O 14	P 3	0
3	3F	1	Total 32	C 10	N 5	O 14	P 3	0
3	3G	1	Total 32	C 10	N 5	O 14	P 3	0
3	3I	1	Total 32	C 10	N 5	O 14	P 3	0
3	3J	1	Total 32	C 10	N 5	O 14	P 3	0
3	3K	1	Total 32	C 10	N 5	O 14	P 3	0
3	3L	1	Total 32	C 10	N 5	O 14	P 3	0
3	3M	1	Total 32	C 10	N 5	O 14	P 3	0
3	3N	1	Total 32	C 10	N 5	O 14	P 3	0
3	4A	1	Total 32	C 10	N 5	O 14	P 3	0
3	4B	1	Total 32	C 10	N 5	O 14	P 3	0
3	4C	1	Total 32	C 10	N 5	O 14	P 3	0
3	4D	1	Total 32	C 10	N 5	O 14	P 3	0
3	4E	1	Total 32	C 10	N 5	O 14	P 3	0
3	4F	1	Total 32	C 10	N 5	O 14	P 3	0
3	4G	1	Total 32	C 10	N 5	O 14	P 3	0
3	4I	1	Total 32	C 10	N 5	O 14	P 3	0
3	4J	1	Total 32	C 10	N 5	O 14	P 3	0

Continued on next page...

Continued from previous page...

Mol	Chain	Residues	Atoms					AltConf
3	4K	1	Total	C	N	O	P	0
			32	10	5	14	3	
3	4L	1	Total	C	N	O	P	0
			32	10	5	14	3	
3	4M	1	Total	C	N	O	P	0
			32	10	5	14	3	
3	4N	1	Total	C	N	O	P	0
			32	10	5	14	3	

- Molecule 4 is MAGNESIUM ION (three-letter code: MG) (formula: Mg).

Mol	Chain	Residues	Atoms		AltConf
4	1A	1	Total	Mg	0
			1	1	
4	1B	1	Total	Mg	0
			1	1	
4	1C	1	Total	Mg	0
			1	1	
4	1D	1	Total	Mg	0
			1	1	
4	1E	1	Total	Mg	0
			1	1	
4	1F	1	Total	Mg	0
			1	1	
4	1G	1	Total	Mg	0
			1	1	
4	1I	1	Total	Mg	0
			1	1	
4	1J	1	Total	Mg	0
			1	1	
4	1K	1	Total	Mg	0
			1	1	
4	1L	1	Total	Mg	0
			1	1	
4	1M	1	Total	Mg	0
			1	1	
4	1N	1	Total	Mg	0
			1	1	
4	2A	1	Total	Mg	0
			1	1	
4	2B	1	Total	Mg	0
			1	1	

Continued on next page...

Continued from previous page...

Mol	Chain	Residues	Atoms		AltConf
4	2C	1	Total 1	Mg 1	0
4	2D	1	Total 1	Mg 1	0
4	2E	1	Total 1	Mg 1	0
4	2F	1	Total 1	Mg 1	0
4	2G	1	Total 1	Mg 1	0
4	2I	1	Total 1	Mg 1	0
4	2J	1	Total 1	Mg 1	0
4	2K	1	Total 1	Mg 1	0
4	2L	1	Total 1	Mg 1	0
4	2M	1	Total 1	Mg 1	0
4	2N	1	Total 1	Mg 1	0
4	3A	1	Total 1	Mg 1	0
4	3B	1	Total 1	Mg 1	0
4	3C	1	Total 1	Mg 1	0
4	3D	1	Total 1	Mg 1	0
4	3E	1	Total 1	Mg 1	0
4	3F	1	Total 1	Mg 1	0
4	3G	1	Total 1	Mg 1	0
4	3I	1	Total 1	Mg 1	0
4	3J	1	Total 1	Mg 1	0
4	3K	1	Total 1	Mg 1	0

Continued on next page...

Continued from previous page...

Mol	Chain	Residues	Atoms		AltConf
4	3L	1	Total 1	Mg 1	0
4	3M	1	Total 1	Mg 1	0
4	3N	1	Total 1	Mg 1	0
4	4A	1	Total 1	Mg 1	0
4	4B	1	Total 1	Mg 1	0
4	4C	1	Total 1	Mg 1	0
4	4D	1	Total 1	Mg 1	0
4	4E	1	Total 1	Mg 1	0
4	4F	1	Total 1	Mg 1	0
4	4G	1	Total 1	Mg 1	0
4	4I	1	Total 1	Mg 1	0
4	4J	1	Total 1	Mg 1	0
4	4K	1	Total 1	Mg 1	0
4	4L	1	Total 1	Mg 1	0
4	4M	1	Total 1	Mg 1	0
4	4N	1	Total 1	Mg 1	0

- Molecule 5 is GUANOSINE-5'-DIPHOSPHATE (three-letter code: GDP) (formula: $C_{10}H_{15}N_5O_{11}P_2$).

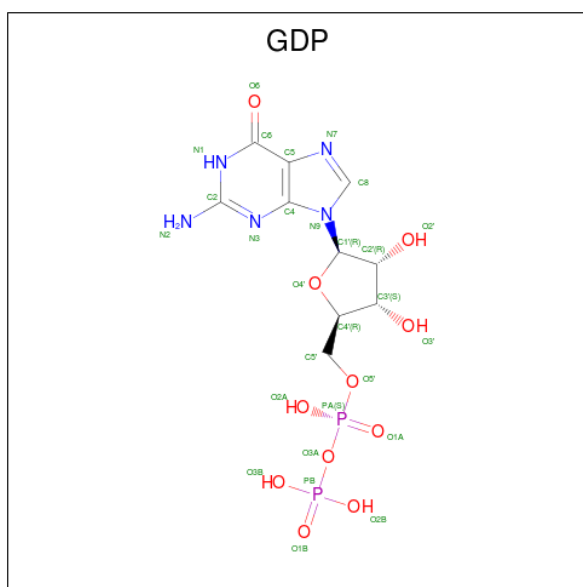

Mol	Chain	Residues	Atoms					AltConf
			Total	C	N	O	P	
5	1H	1	Total	C	N	O	P	0
			28	10	5	11	2	
5	1O	1	Total	C	N	O	P	0
			28	10	5	11	2	
5	1P	1	Total	C	N	O	P	0
			28	10	5	11	2	
5	1Q	1	Total	C	N	O	P	0
			28	10	5	11	2	
5	1R	1	Total	C	N	O	P	0
			28	10	5	11	2	
5	1S	1	Total	C	N	O	P	0
			28	10	5	11	2	
5	1T	1	Total	C	N	O	P	0
			28	10	5	11	2	
5	1U	1	Total	C	N	O	P	0
			28	10	5	11	2	
5	1V	1	Total	C	N	O	P	0
			28	10	5	11	2	
5	1W	1	Total	C	N	O	P	0
			28	10	5	11	2	
5	1X	1	Total	C	N	O	P	0
			28	10	5	11	2	
5	1Y	1	Total	C	N	O	P	0
			28	10	5	11	2	
5	1Z	1	Total	C	N	O	P	0
			28	10	5	11	2	
5	2H	1	Total	C	N	O	P	0
			28	10	5	11	2	

Continued on next page...

Continued from previous page...

Mol	Chain	Residues	Atoms					AltConf
			Total	C	N	O	P	
5	2O	1	28	10	5	11	2	0
5	2P	1	28	10	5	11	2	0
5	2Q	1	28	10	5	11	2	0
5	2R	1	28	10	5	11	2	0
5	2S	1	28	10	5	11	2	0
5	2T	1	28	10	5	11	2	0
5	2U	1	28	10	5	11	2	0
5	2V	1	28	10	5	11	2	0
5	2W	1	28	10	5	11	2	0
5	2X	1	28	10	5	11	2	0
5	2Y	1	28	10	5	11	2	0
5	2Z	1	28	10	5	11	2	0
5	3H	1	28	10	5	11	2	0
5	3O	1	28	10	5	11	2	0
5	3P	1	28	10	5	11	2	0
5	3Q	1	28	10	5	11	2	0
5	3R	1	28	10	5	11	2	0
5	3S	1	28	10	5	11	2	0
5	3T	1	28	10	5	11	2	0
5	3U	1	28	10	5	11	2	0
5	3V	1	28	10	5	11	2	0

Continued on next page...

Continued from previous page...

Mol	Chain	Residues	Atoms					AltConf
			Total	C	N	O	P	
5	3W	1	Total 28	C 10	N 5	O 11	P 2	0
5	3X	1	Total 28	C 10	N 5	O 11	P 2	0
5	3Y	1	Total 28	C 10	N 5	O 11	P 2	0
5	3Z	1	Total 28	C 10	N 5	O 11	P 2	0
5	4H	1	Total 28	C 10	N 5	O 11	P 2	0
5	4O	1	Total 28	C 10	N 5	O 11	P 2	0
5	4P	1	Total 28	C 10	N 5	O 11	P 2	0
5	4Q	1	Total 28	C 10	N 5	O 11	P 2	0
5	4R	1	Total 28	C 10	N 5	O 11	P 2	0
5	4S	1	Total 28	C 10	N 5	O 11	P 2	0
5	4T	1	Total 28	C 10	N 5	O 11	P 2	0
5	4U	1	Total 28	C 10	N 5	O 11	P 2	0
5	4V	1	Total 28	C 10	N 5	O 11	P 2	0
5	4W	1	Total 28	C 10	N 5	O 11	P 2	0
5	4X	1	Total 28	C 10	N 5	O 11	P 2	0
5	4Y	1	Total 28	C 10	N 5	O 11	P 2	0
5	4Z	1	Total 28	C 10	N 5	O 11	P 2	0

3 Residue-property plots

These plots are drawn for all protein, RNA, DNA and oligosaccharide chains in the entry. The first graphic for a chain summarises the proportions of the various outlier classes displayed in the second graphic. The second graphic shows the sequence view annotated by issues in geometry and atom inclusion in map density. Residues are color-coded according to the number of geometric quality criteria for which they contain at least one outlier: green = 0, yellow = 1, orange = 2 and red = 3 or more. A red diamond above a residue indicates a poor fit to the EM map for this residue (all-atom inclusion < 40%). Stretches of 2 or more consecutive residues without any outlier are shown as a green connector. Residues present in the sample, but not in the model, are shown in grey.

- Molecule 1: Tubulin alpha-1B chain

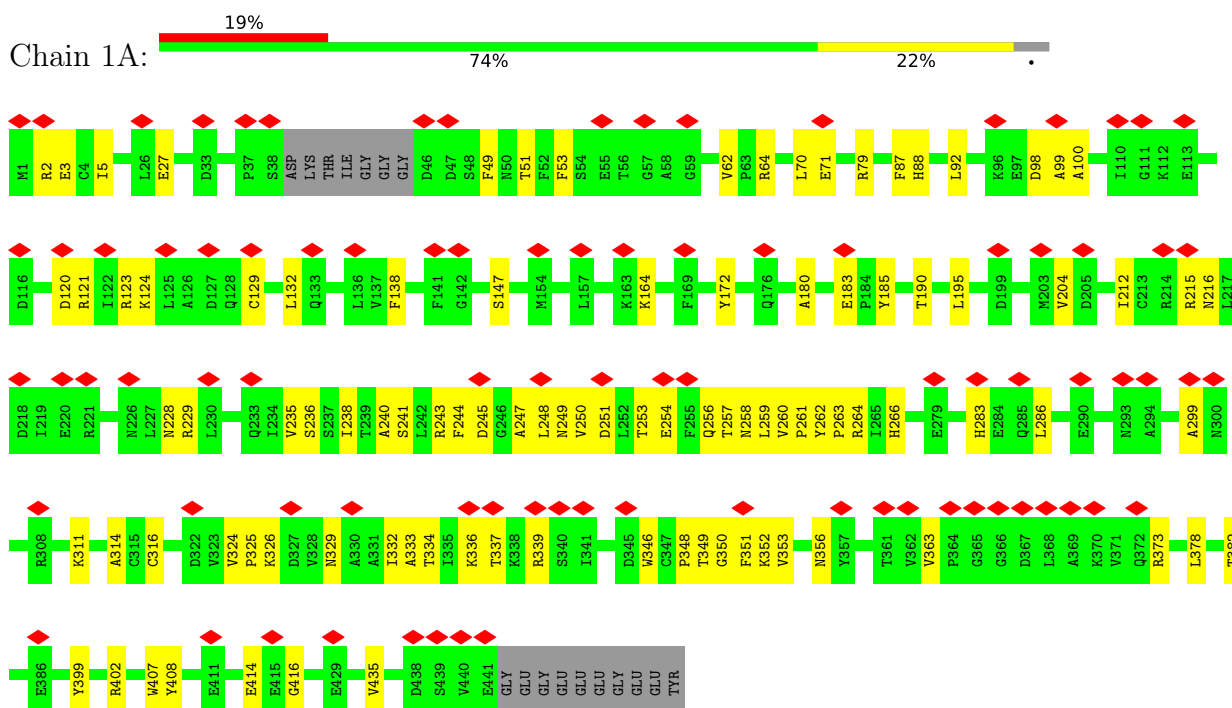

- Molecule 1: Tubulin alpha-1B chain

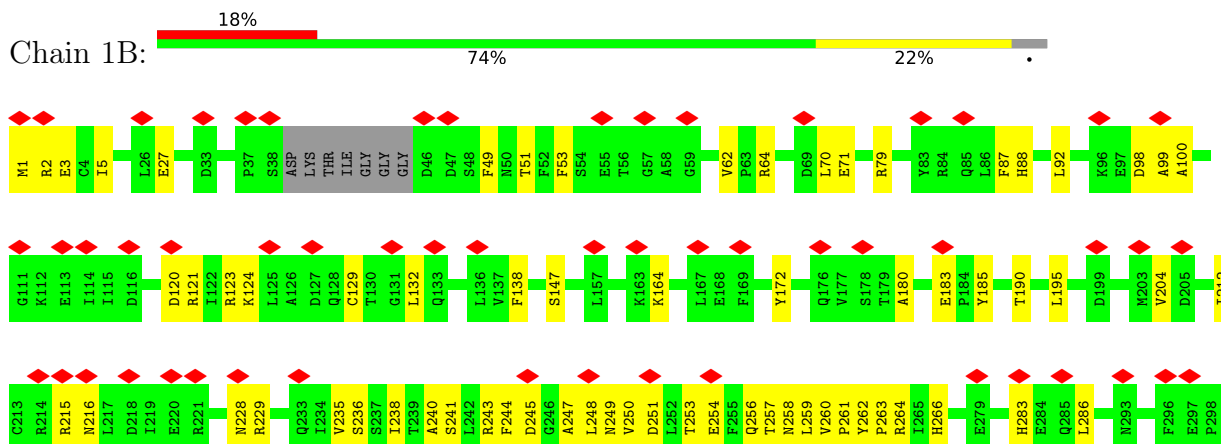

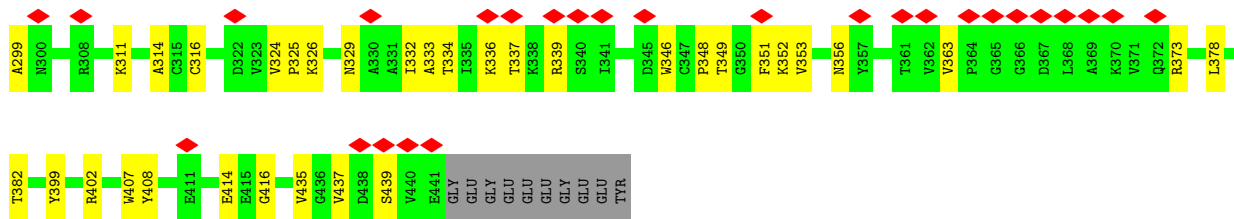

• Molecule 1: Tubulin alpha-1B chain

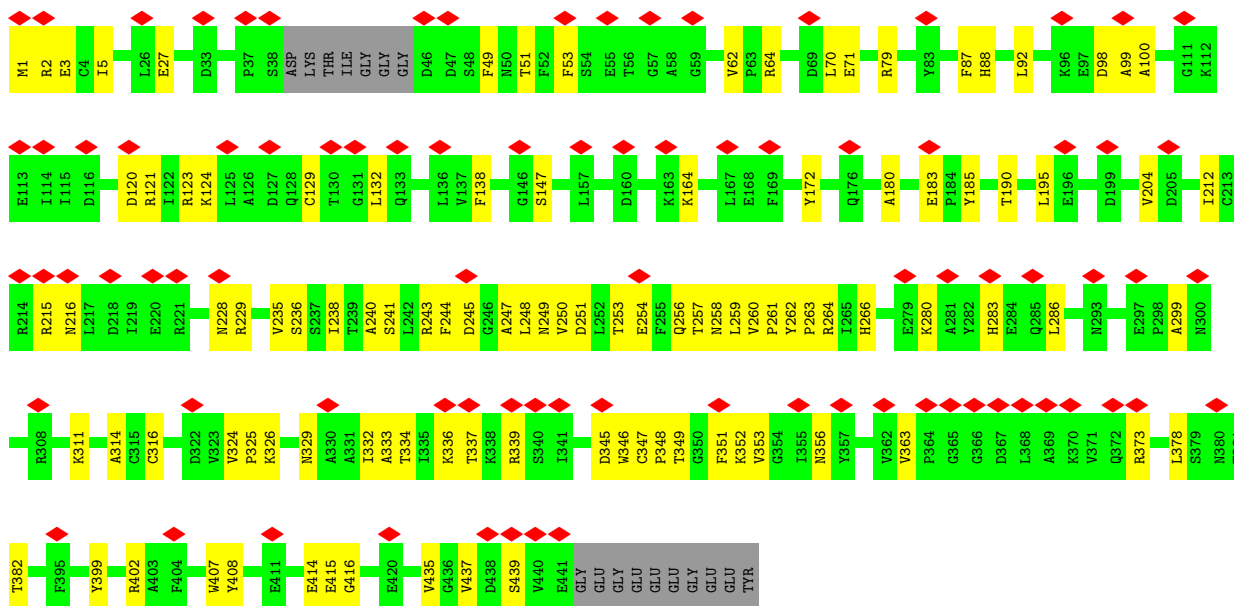
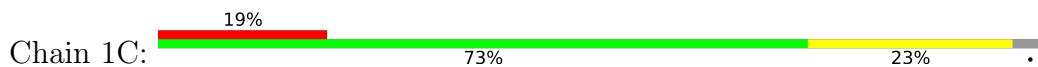

• Molecule 1: Tubulin alpha-1B chain

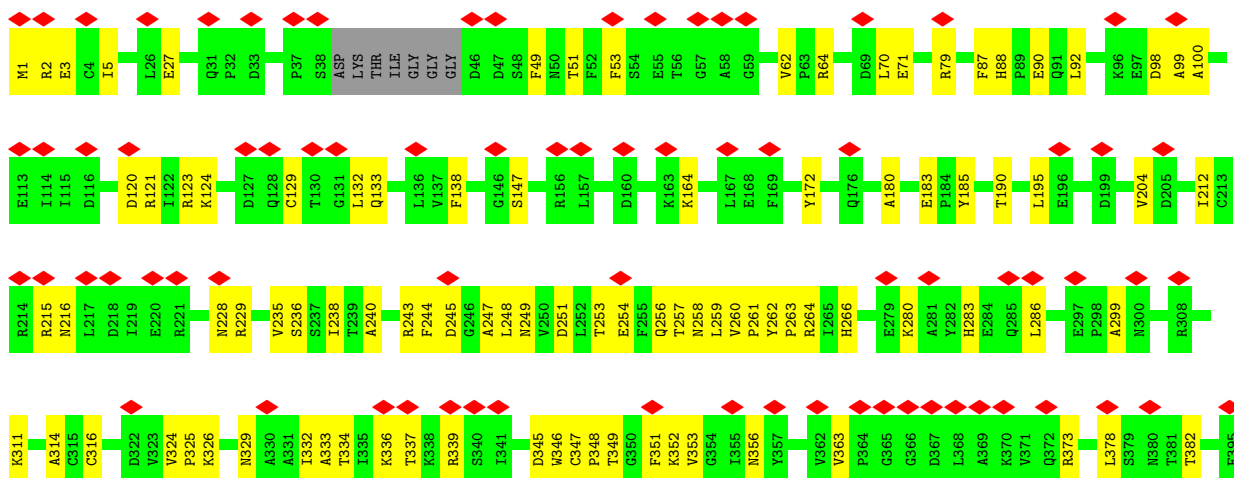
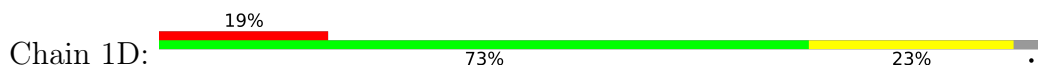

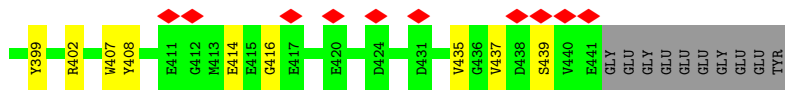

• Molecule 1: Tubulin alpha-1B chain

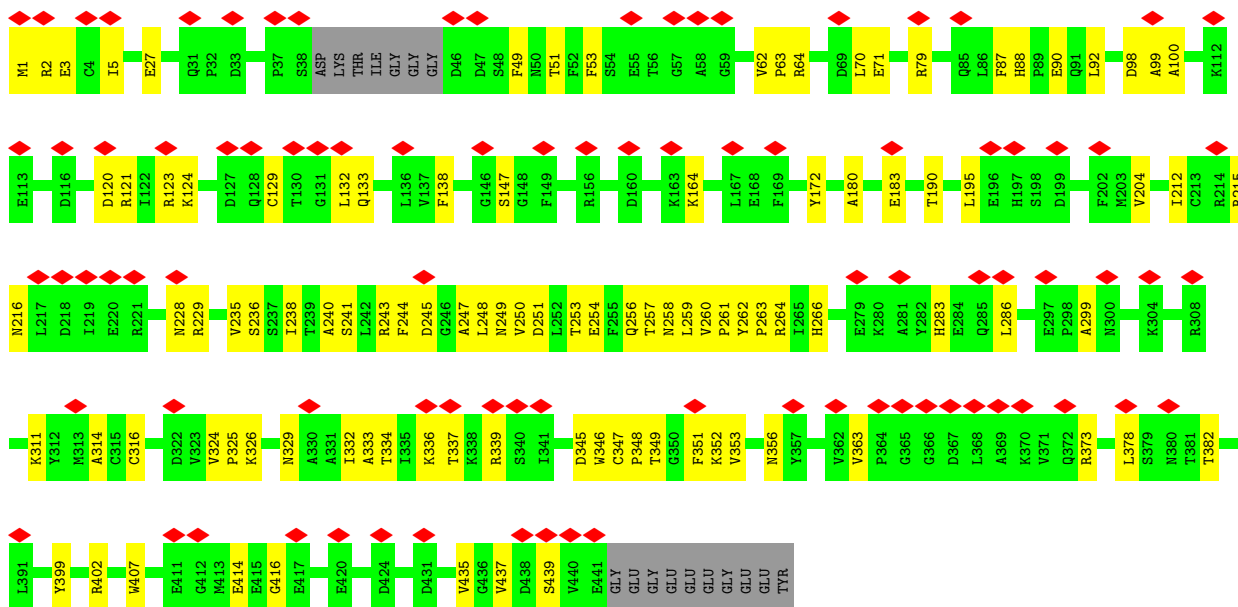
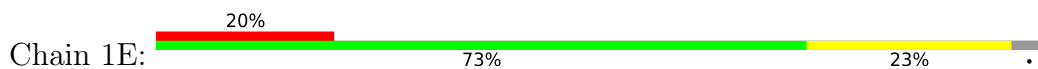

• Molecule 1: Tubulin alpha-1B chain

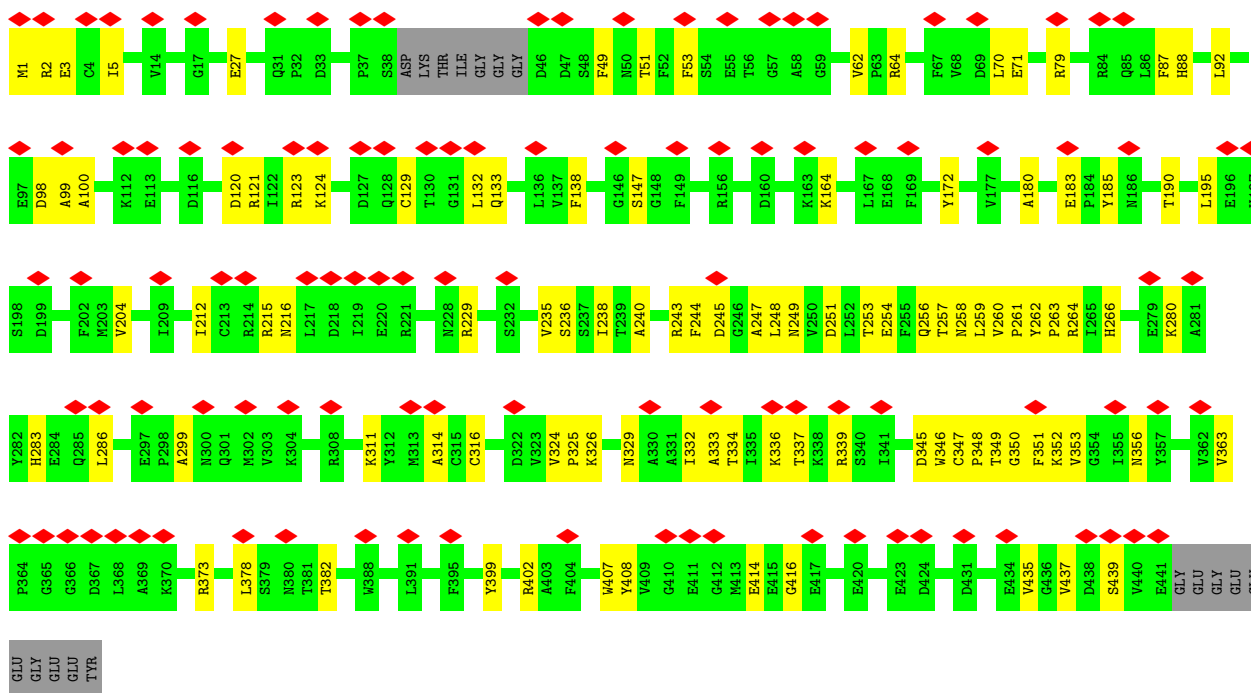
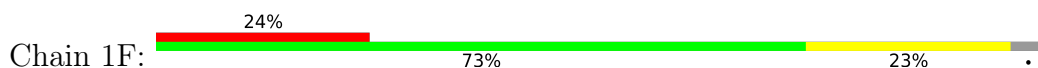

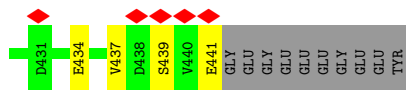

• Molecule 1: Tubulin alpha-1B chain

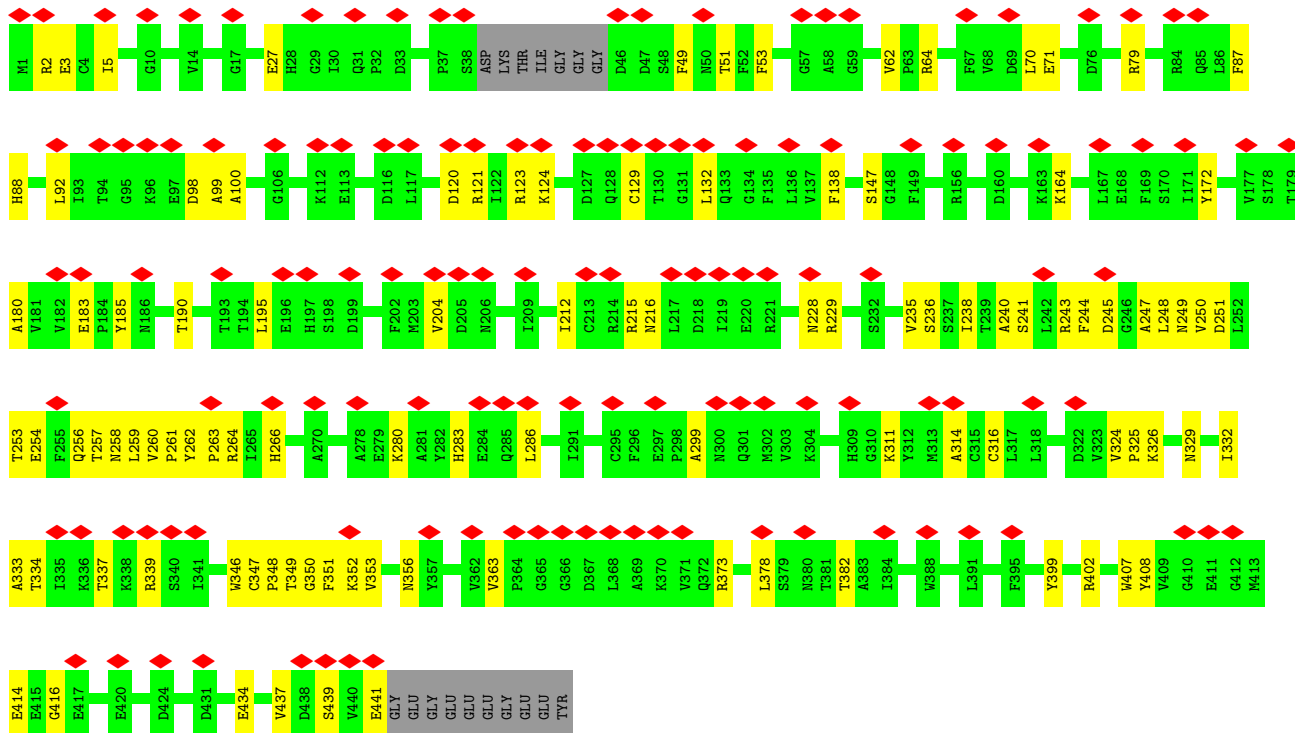
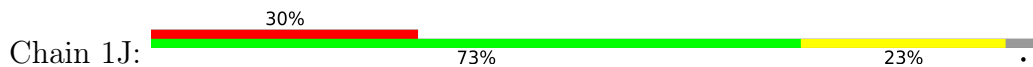

• Molecule 1: Tubulin alpha-1B chain

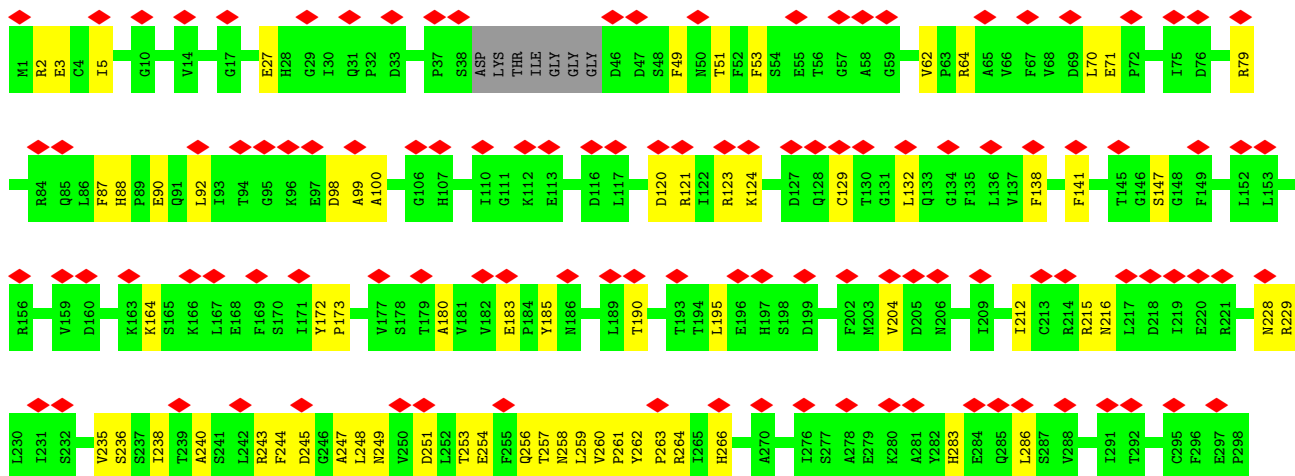
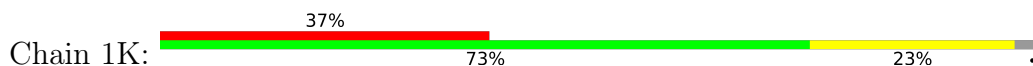

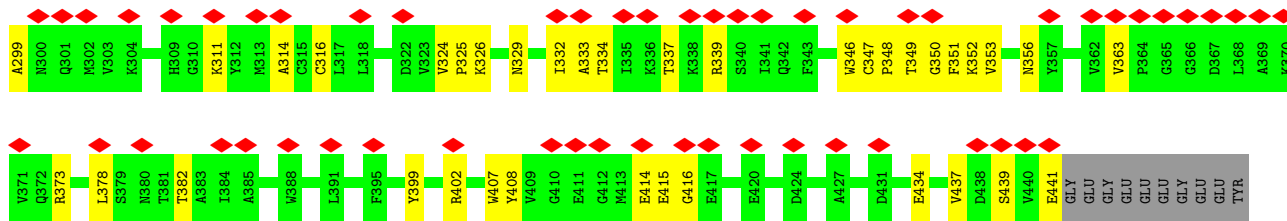

• Molecule 1: Tubulin alpha-1B chain

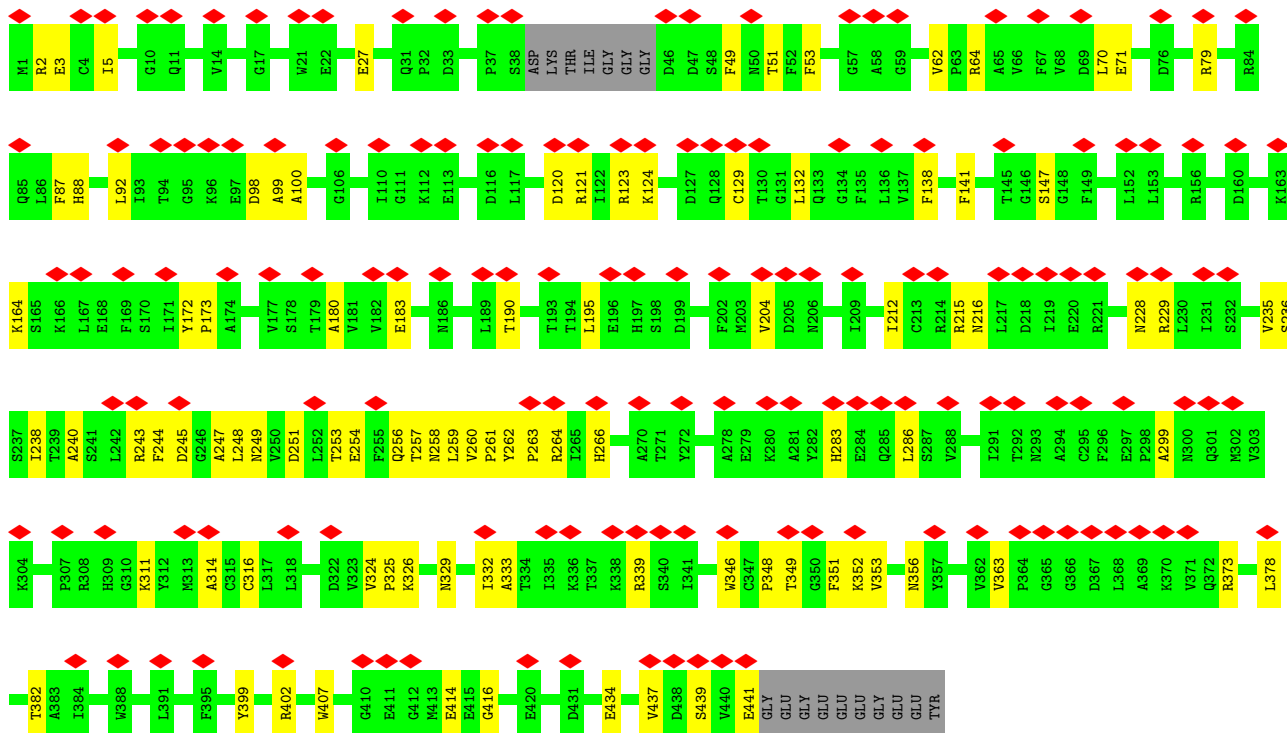
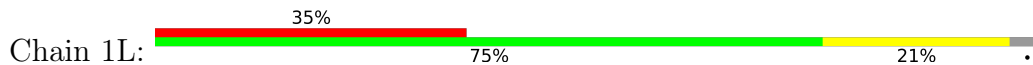

• Molecule 1: Tubulin alpha-1B chain

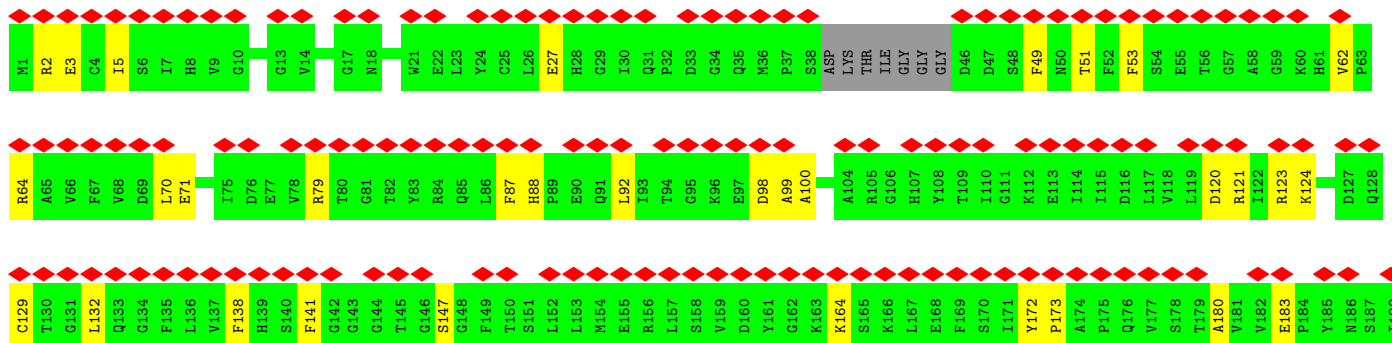
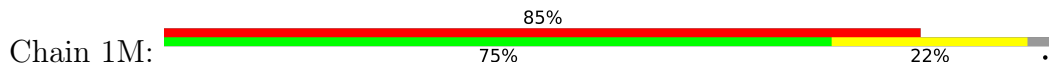

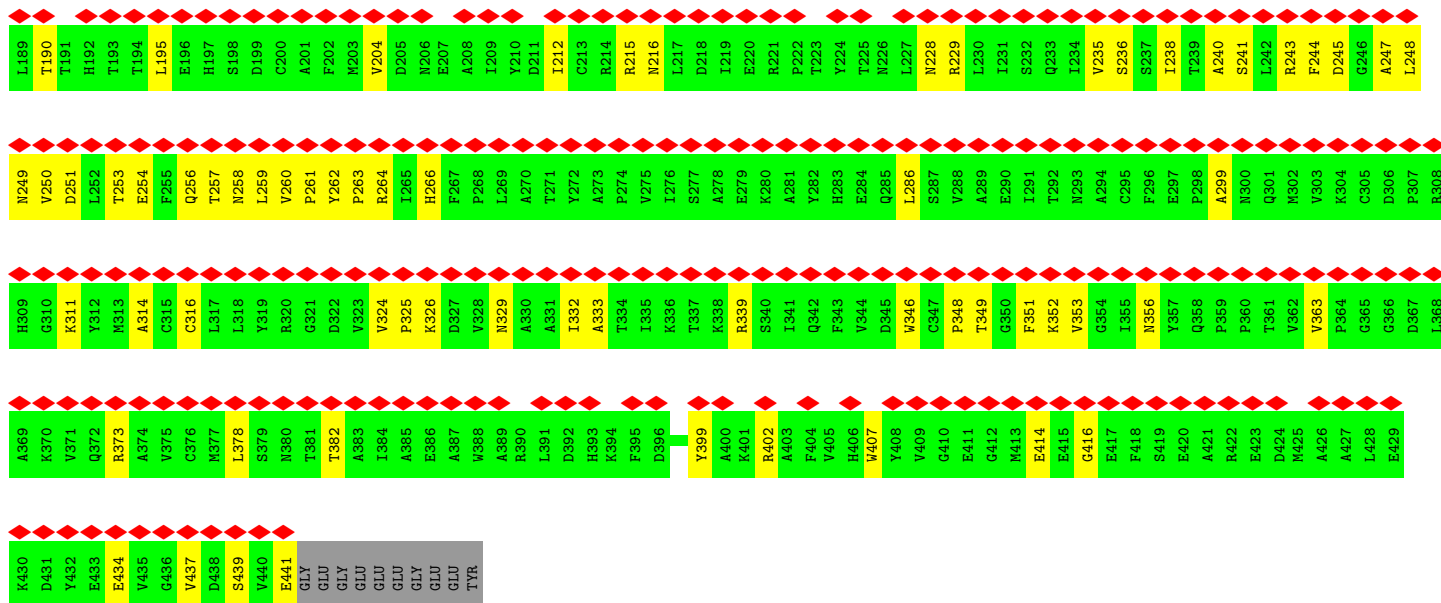

• Molecule 1: Tubulin alpha-1B chain

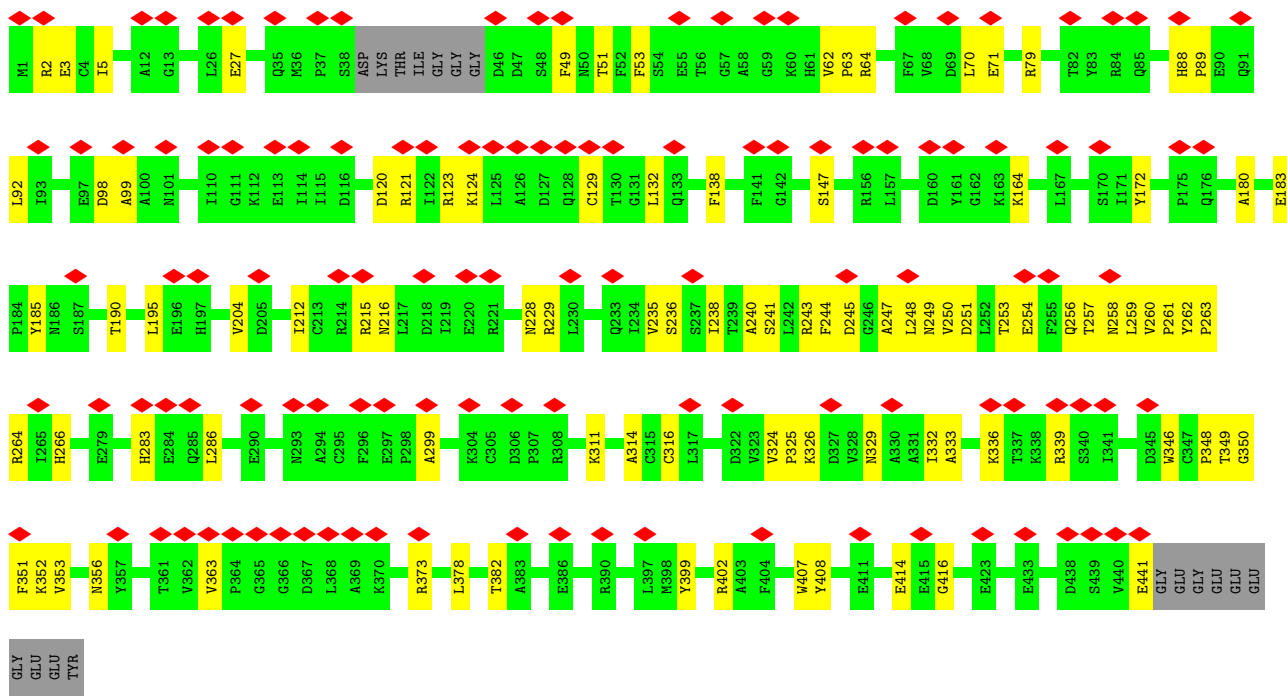
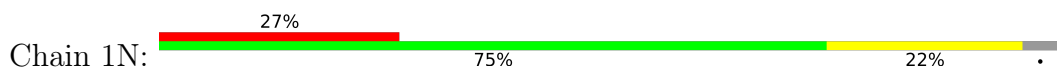

• Molecule 1: Tubulin alpha-1B chain

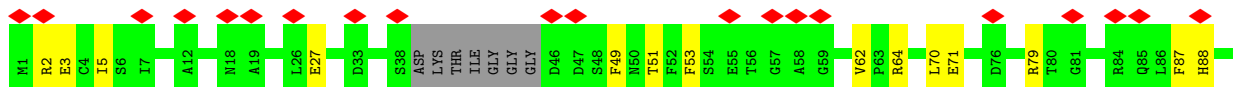
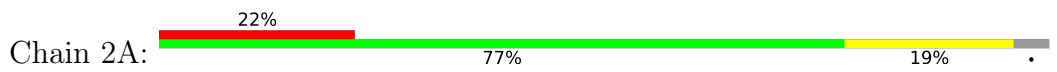

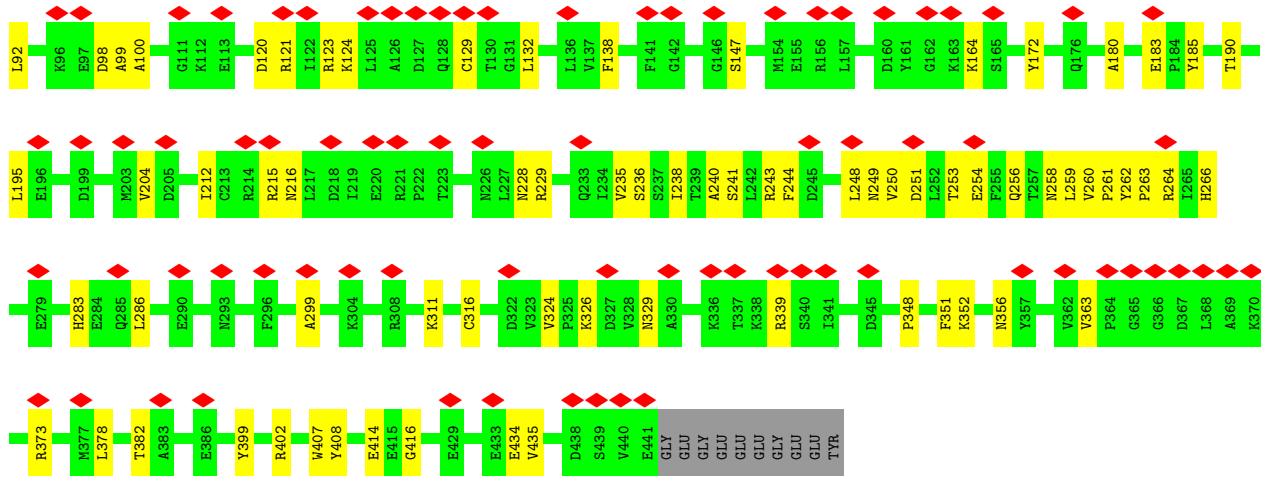

• Molecule 1: Tubulin alpha-1B chain

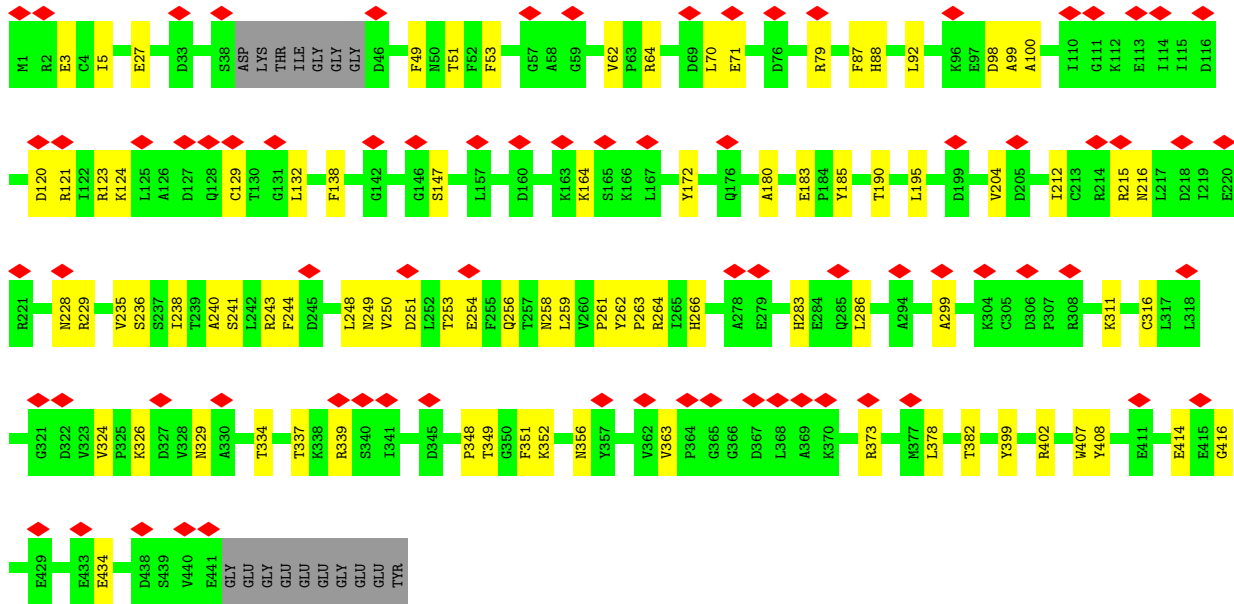
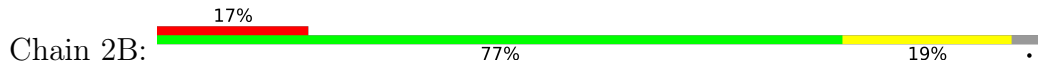

• Molecule 1: Tubulin alpha-1B chain

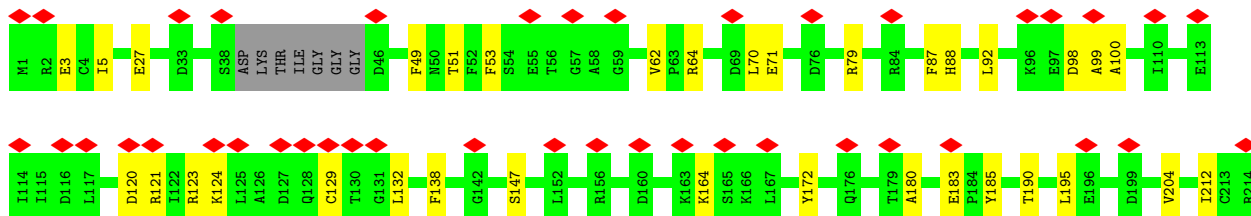
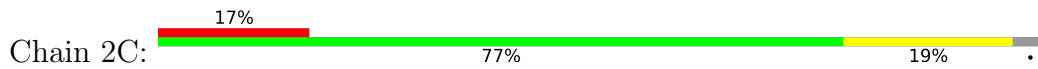

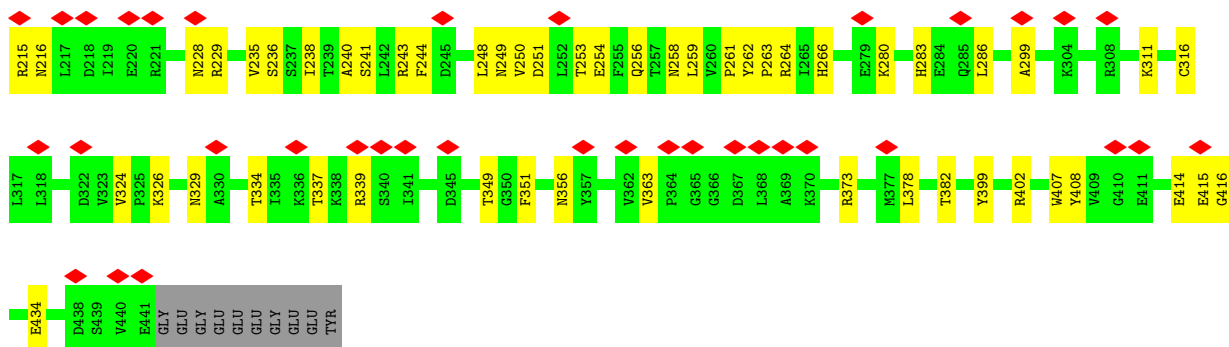

• Molecule 1: Tubulin alpha-1B chain

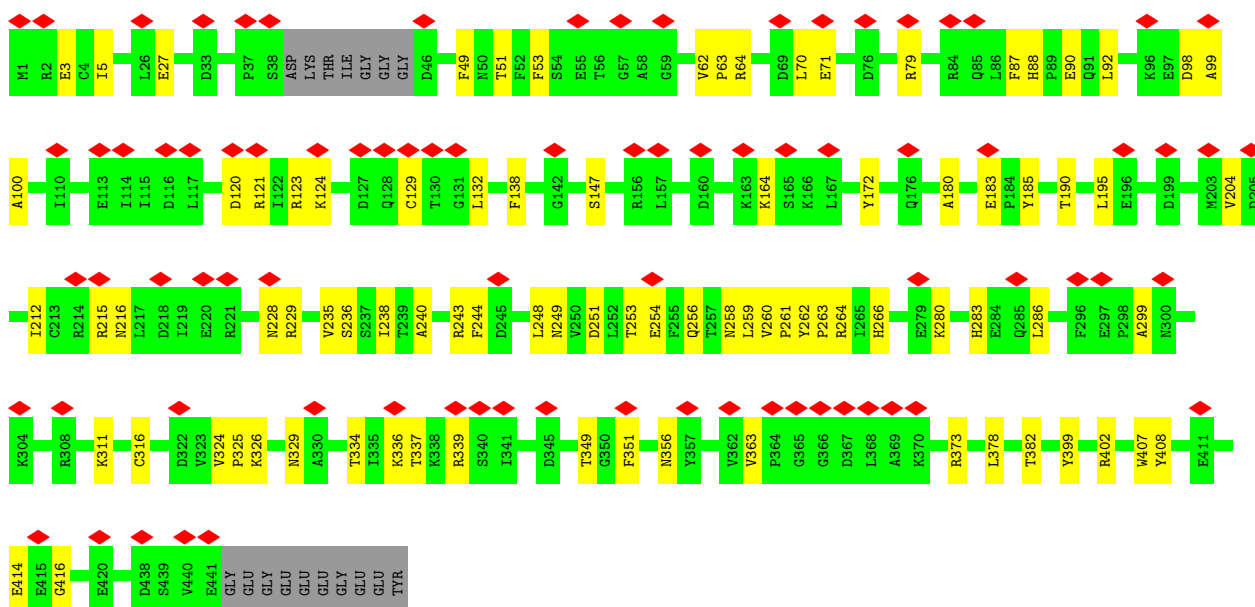
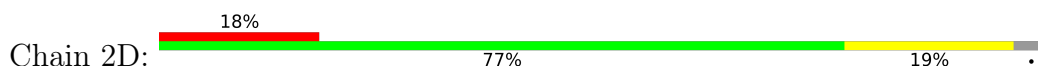

• Molecule 1: Tubulin alpha-1B chain

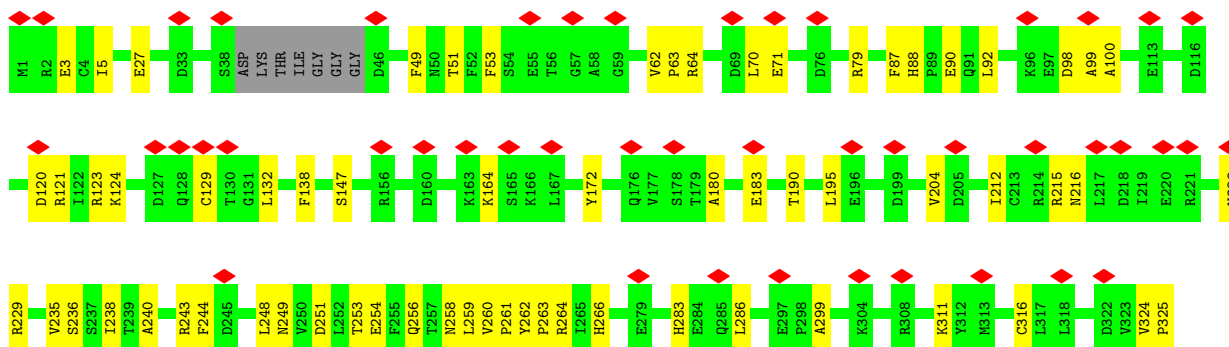
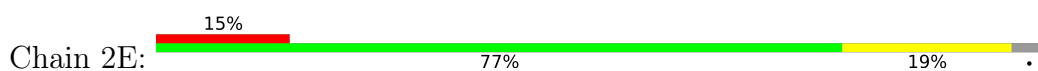

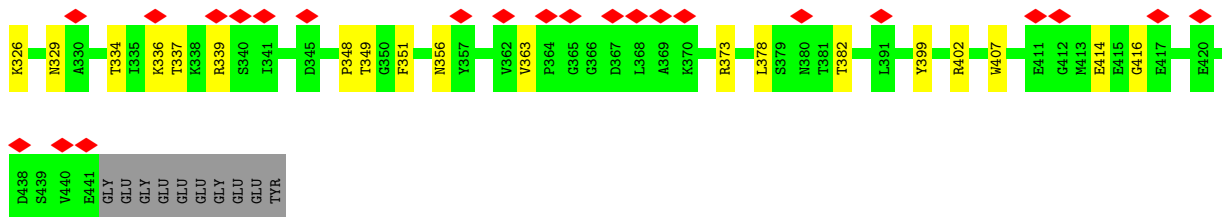

• Molecule 1: Tubulin alpha-1B chain

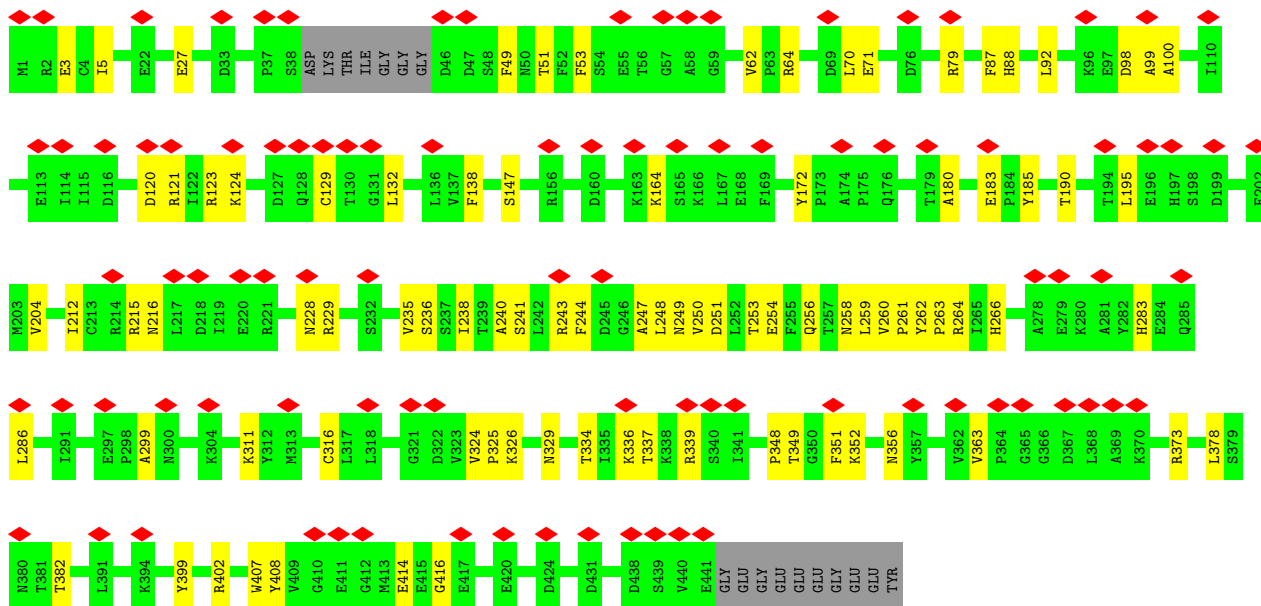
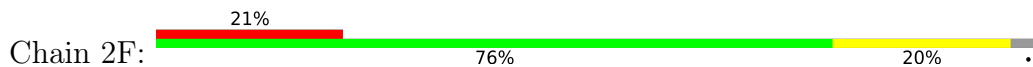

• Molecule 1: Tubulin alpha-1B chain

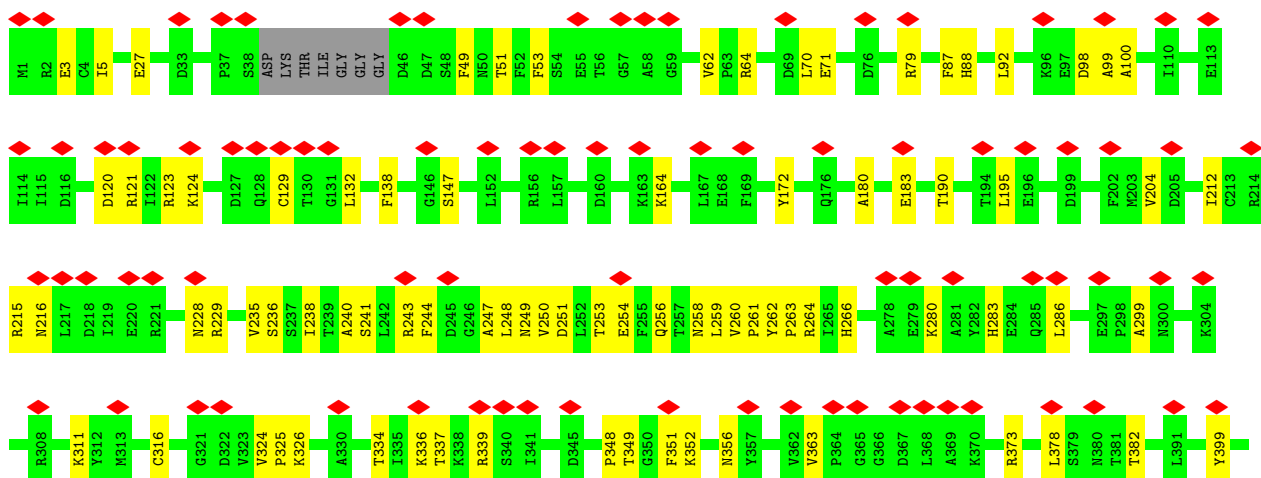
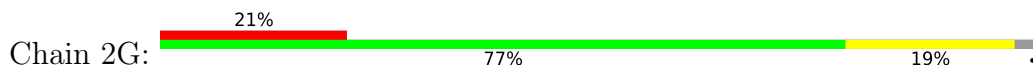

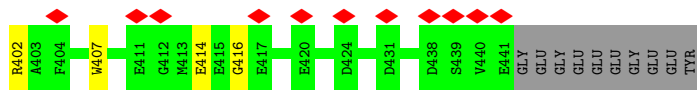

• Molecule 1: Tubulin alpha-1B chain

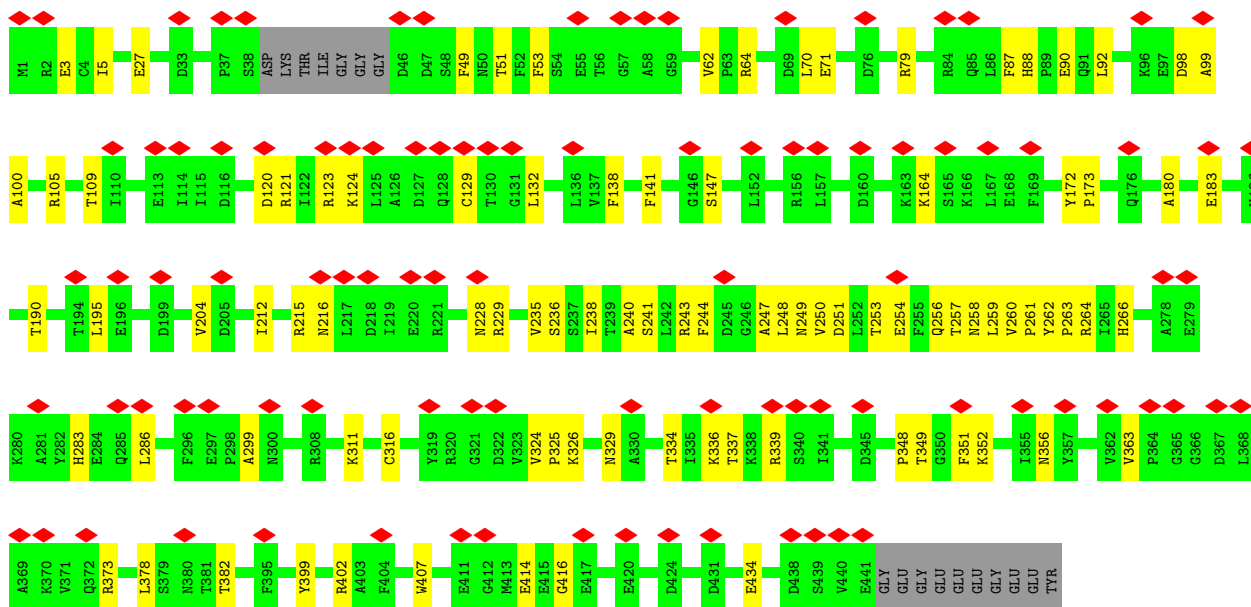
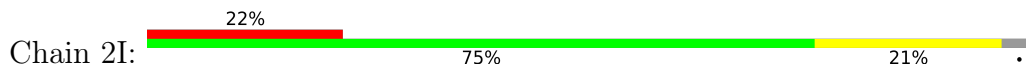

• Molecule 1: Tubulin alpha-1B chain

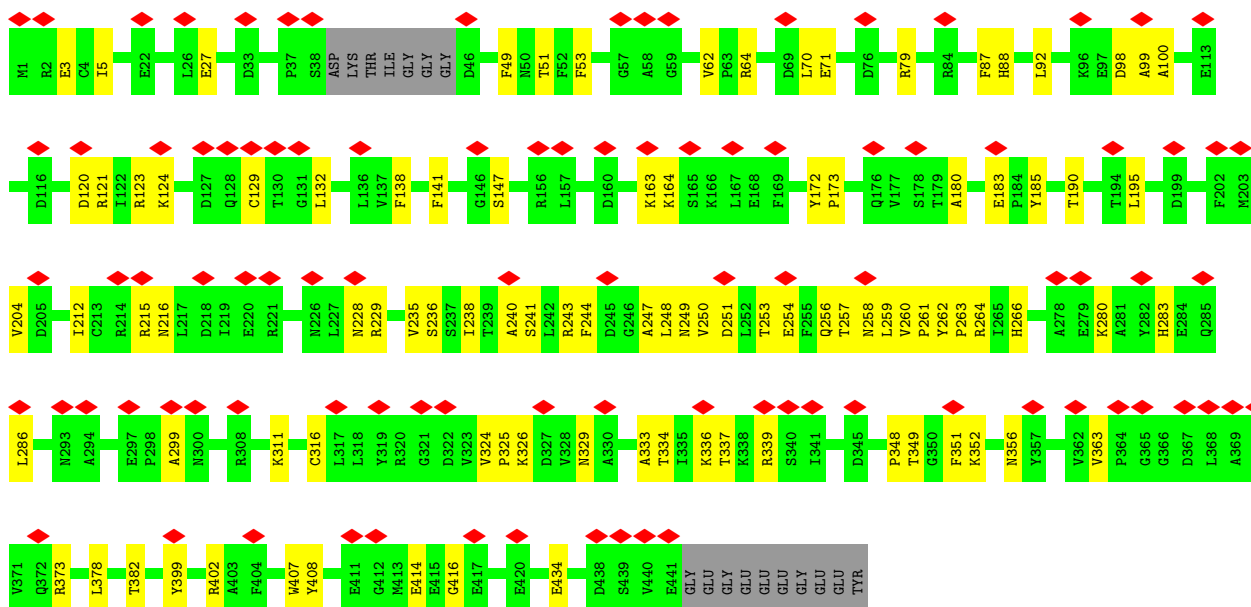
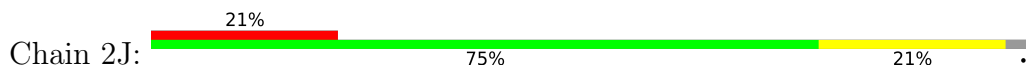

• Molecule 1: Tubulin alpha-1B chain

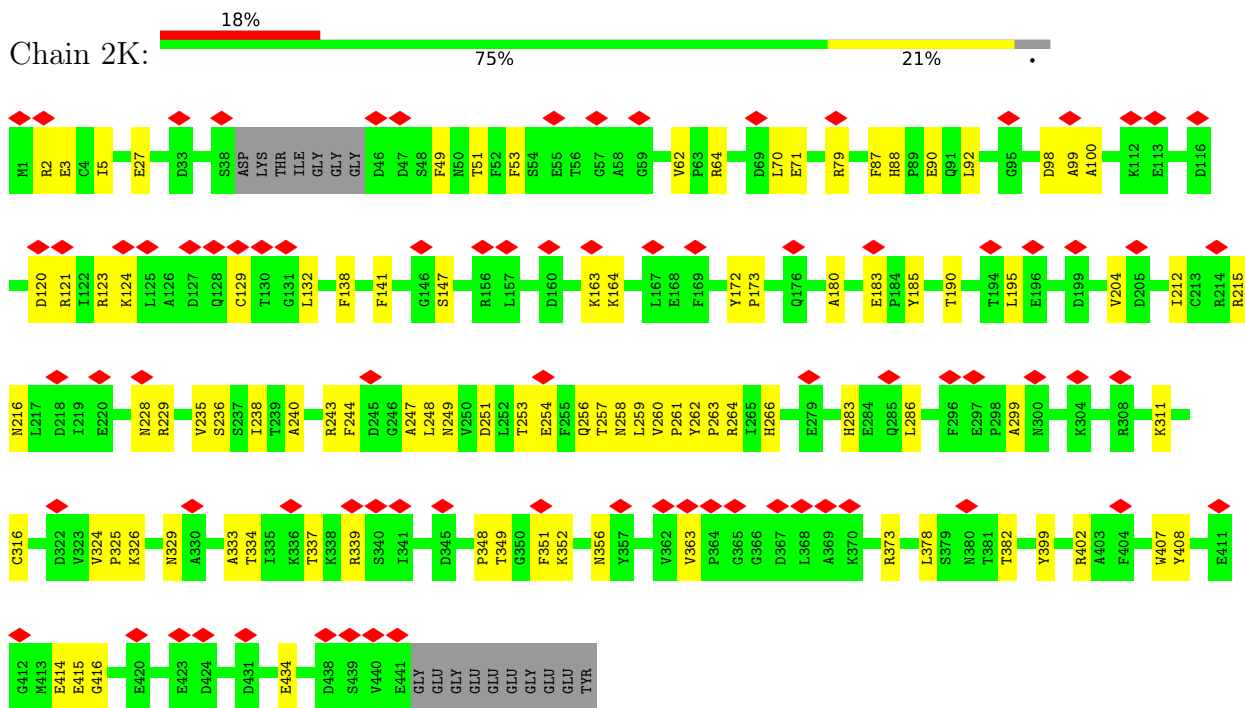

• Molecule 1: Tubulin alpha-1B chain

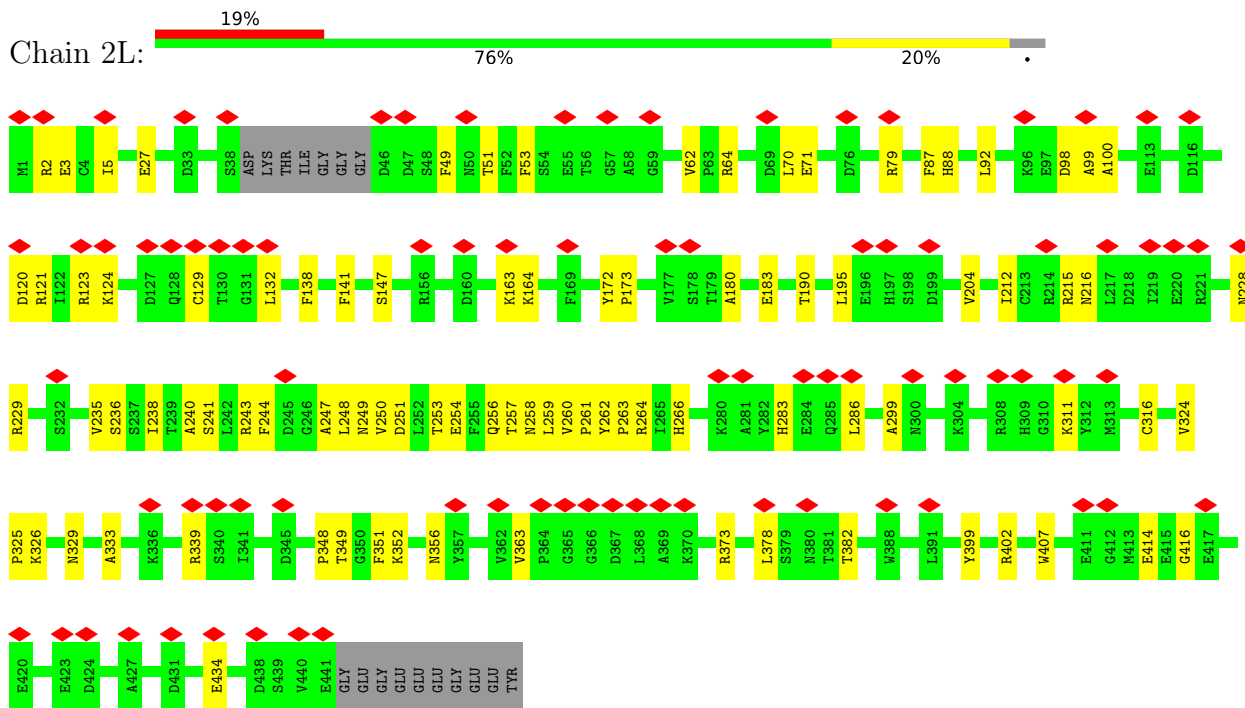

• Molecule 1: Tubulin alpha-1B chain

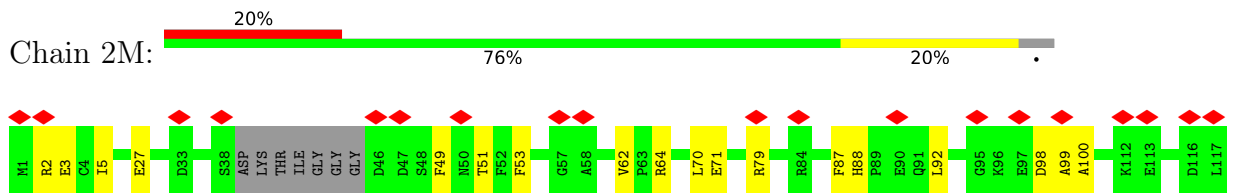

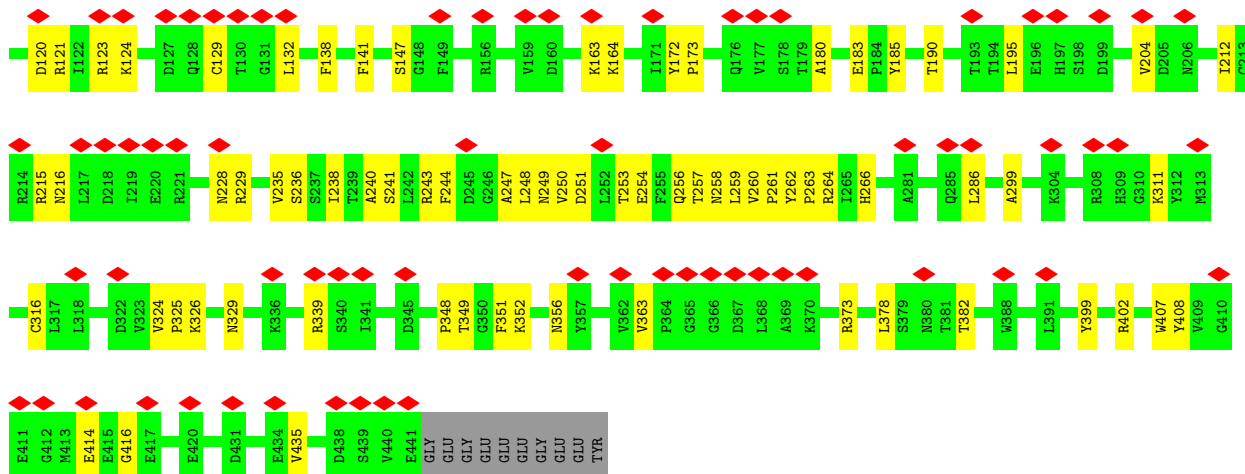

• Molecule 1: Tubulin alpha-1B chain

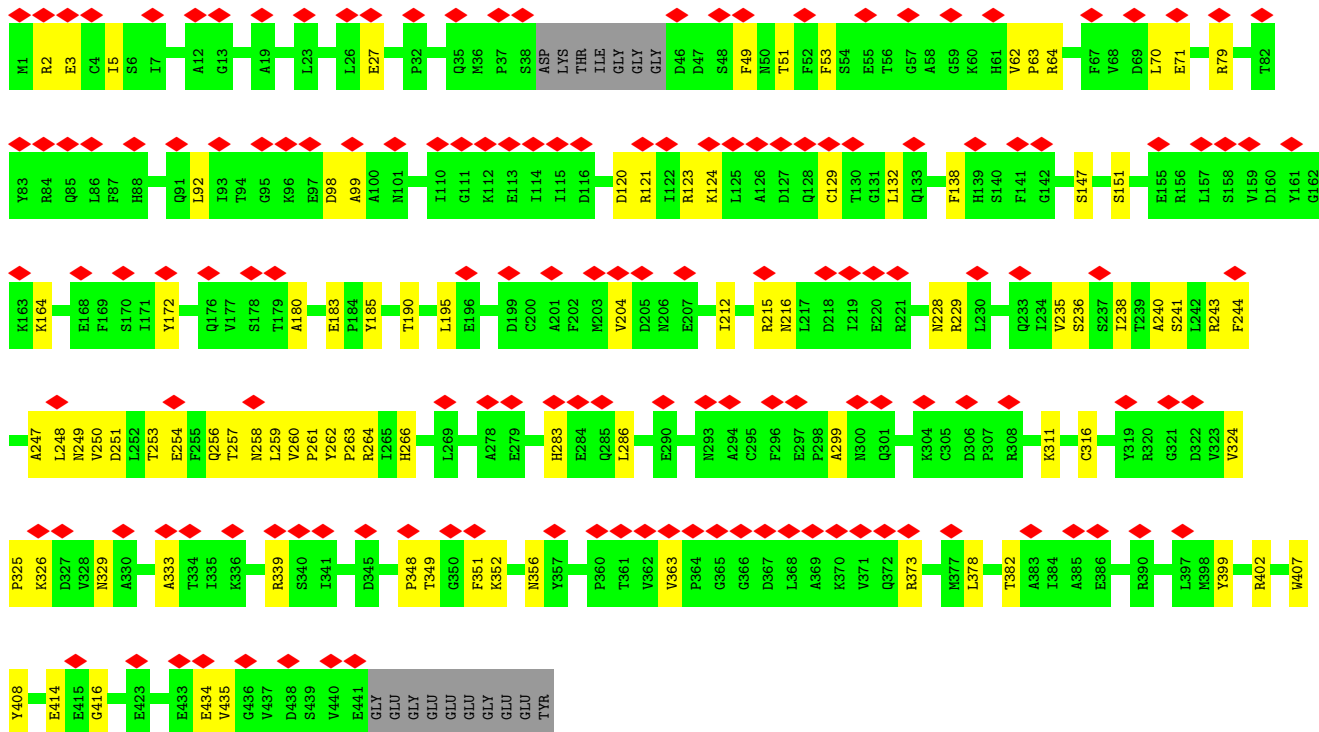
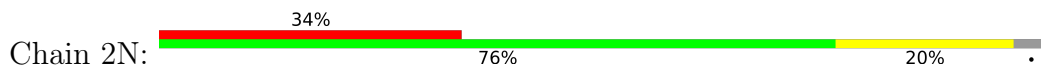

• Molecule 1: Tubulin alpha-1B chain

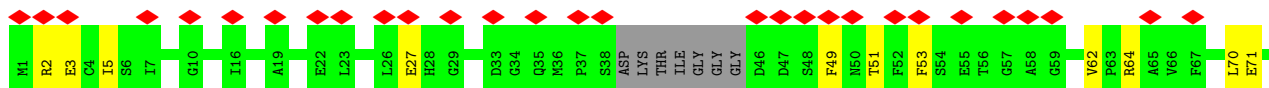
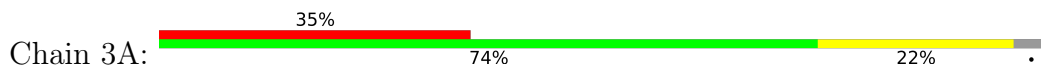

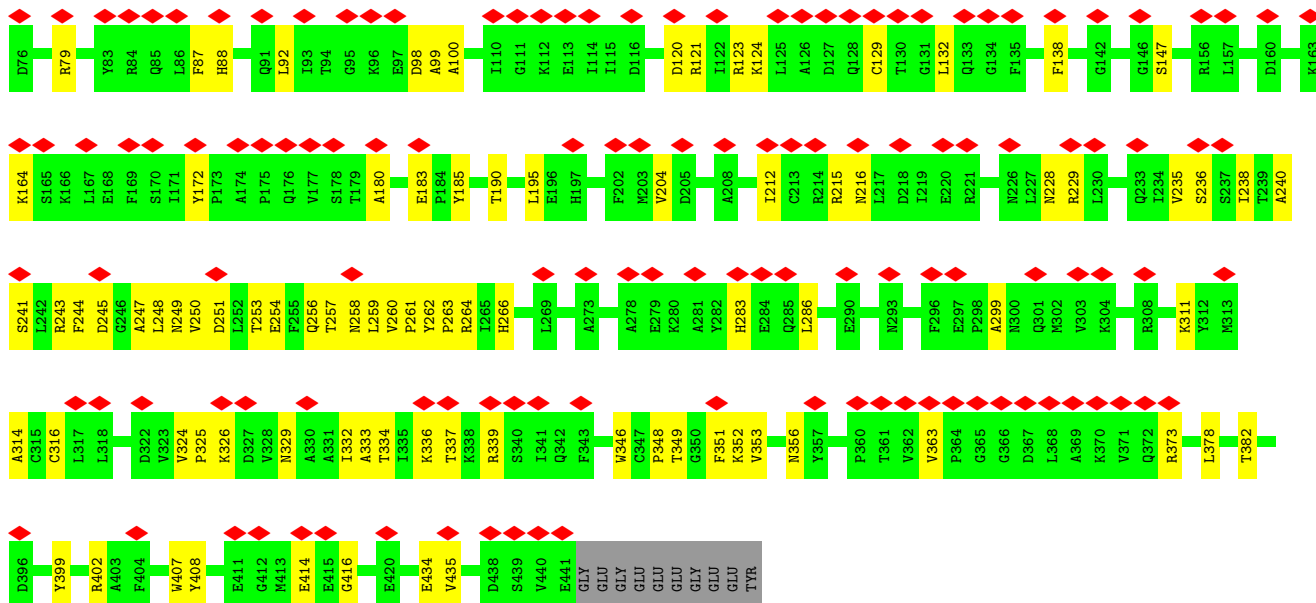

• Molecule 1: Tubulin alpha-1B chain

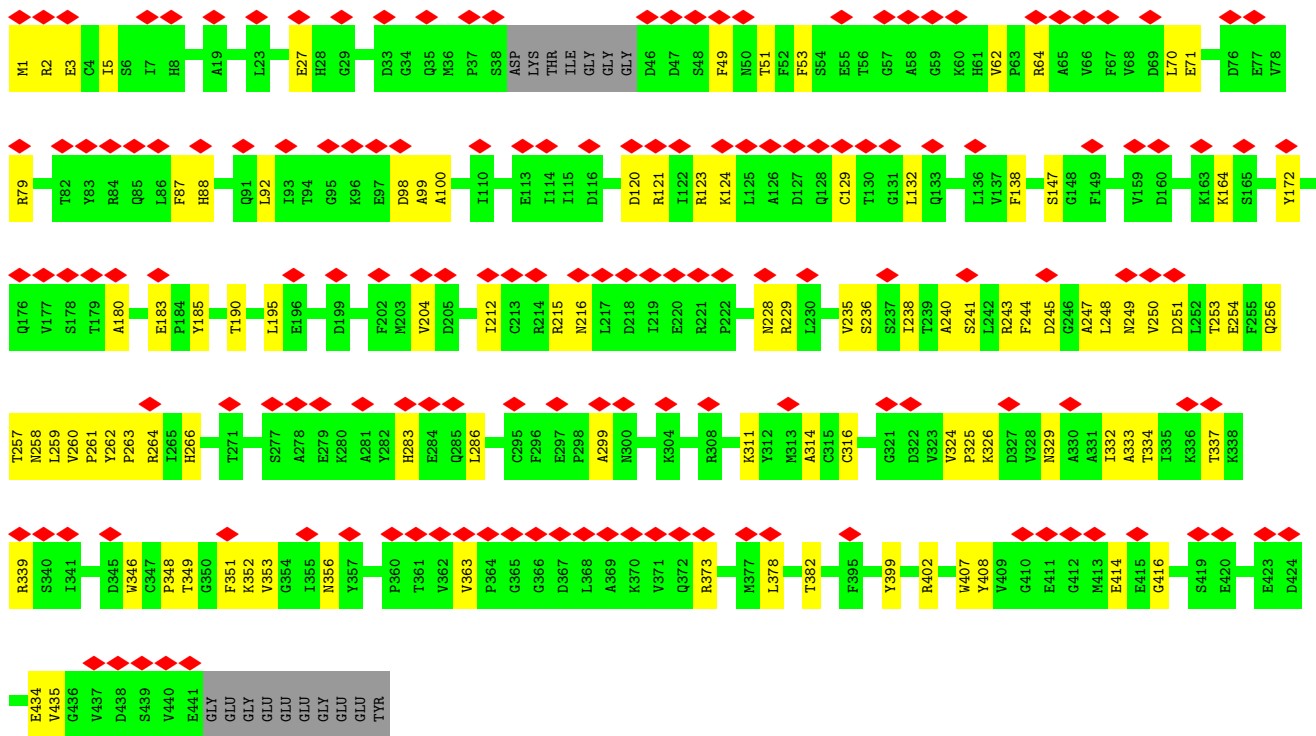
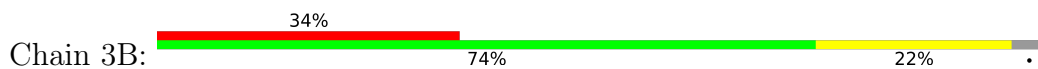

• Molecule 1: Tubulin alpha-1B chain

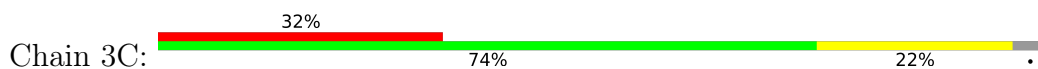

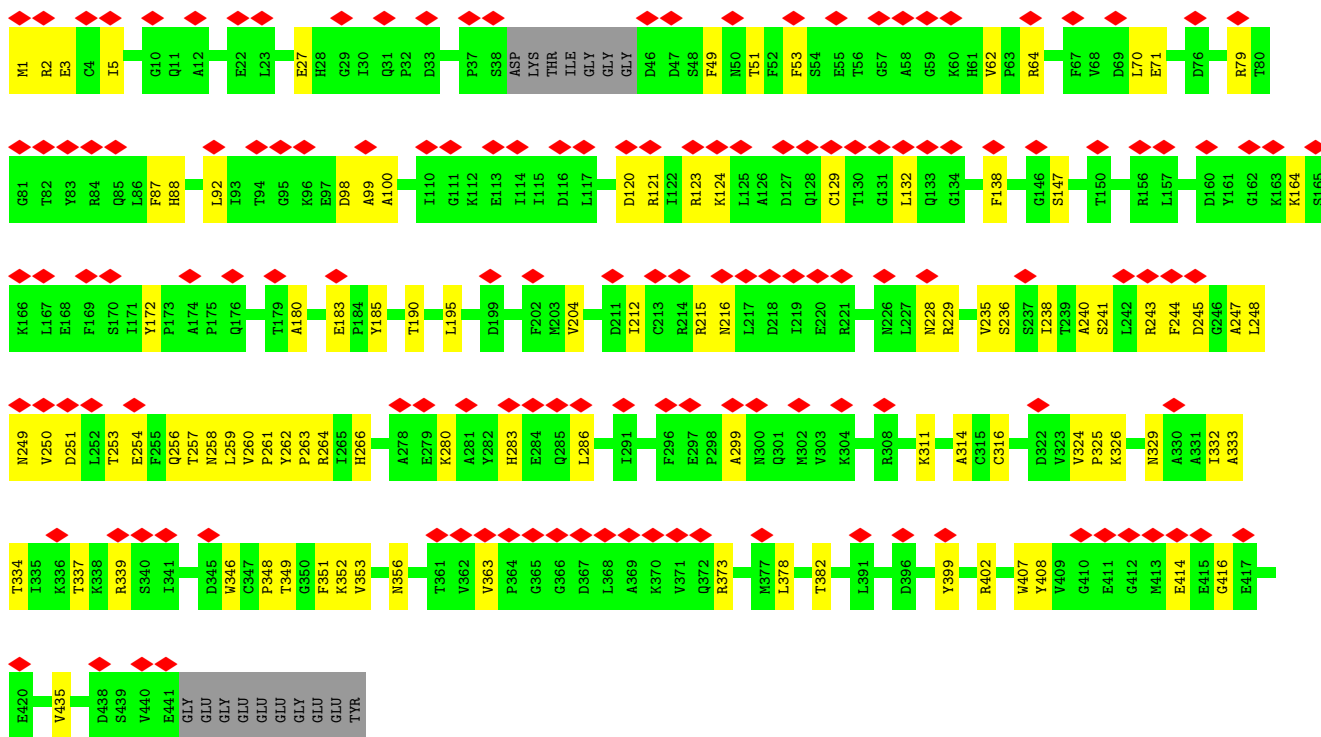

• Molecule 1: Tubulin alpha-1B chain

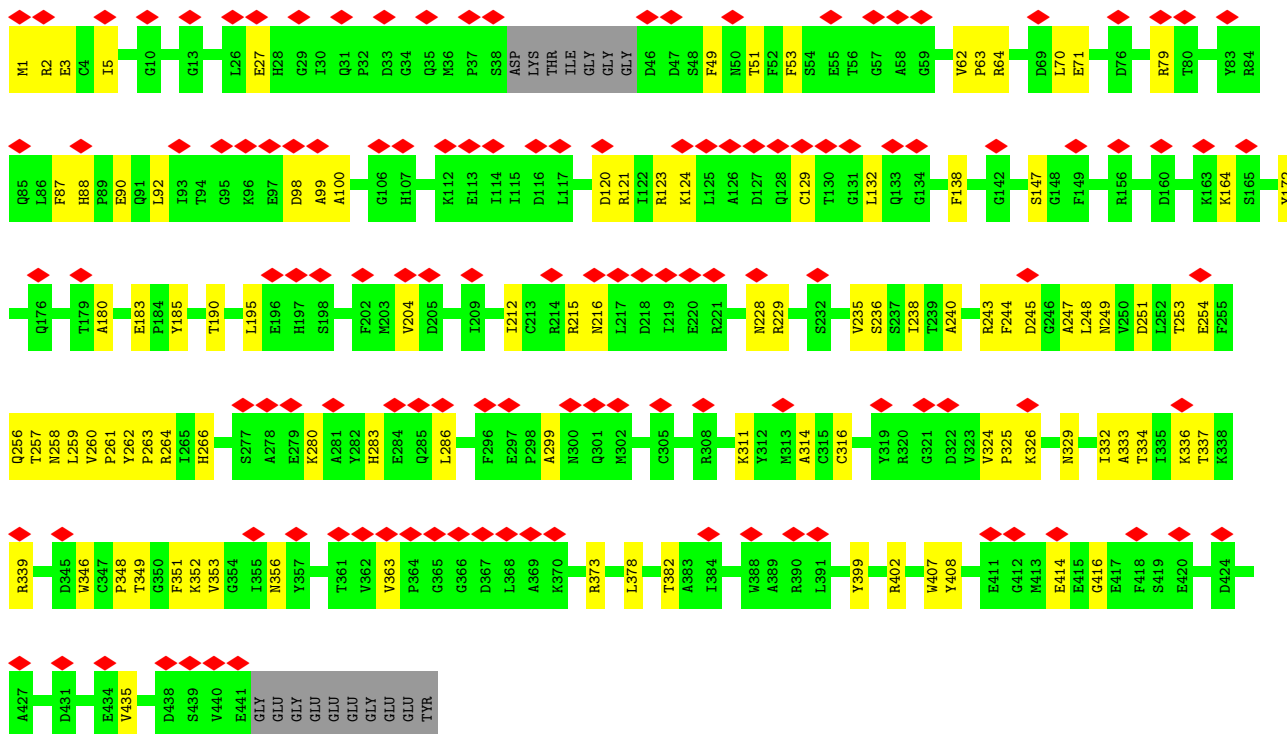
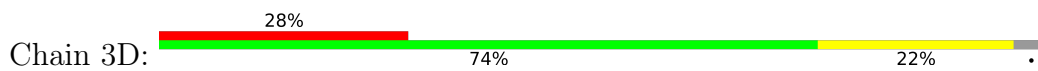

• Molecule 1: Tubulin alpha-1B chain

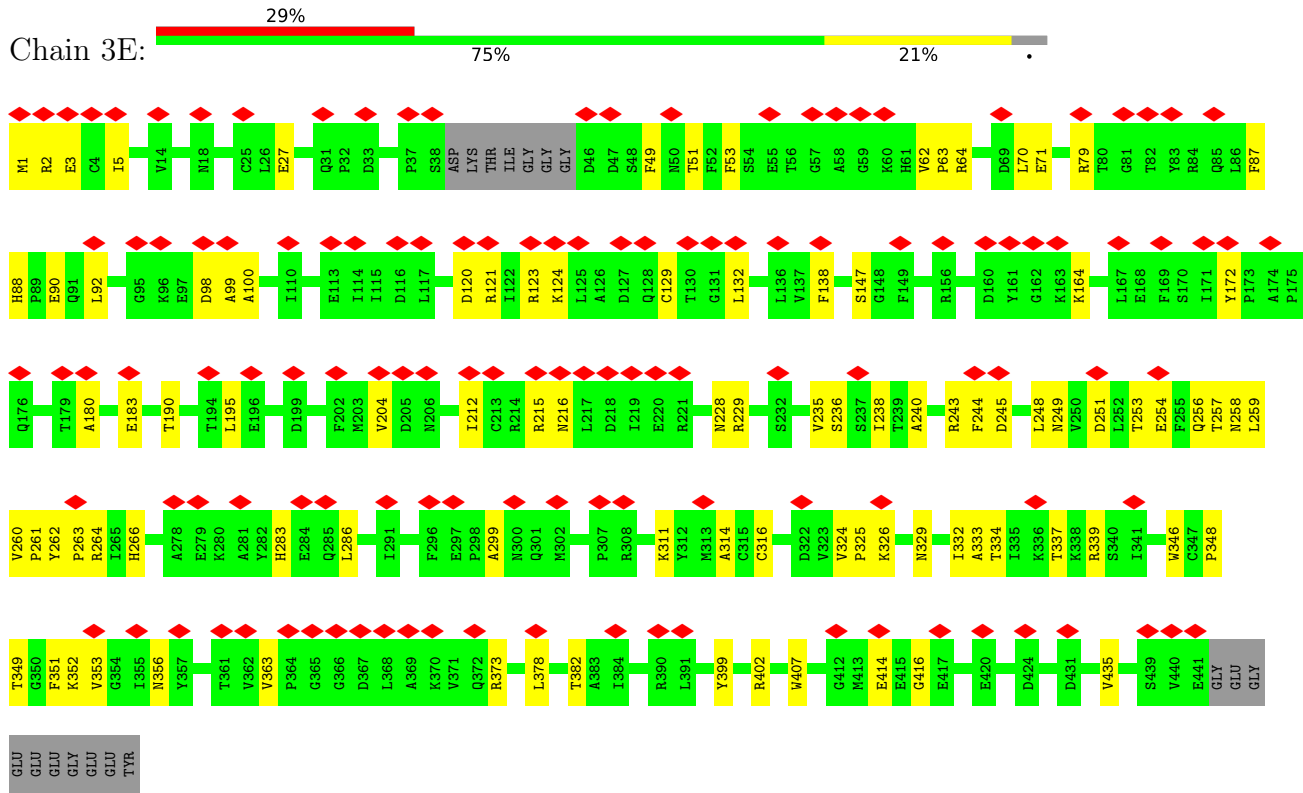

• Molecule 1: Tubulin alpha-1B chain

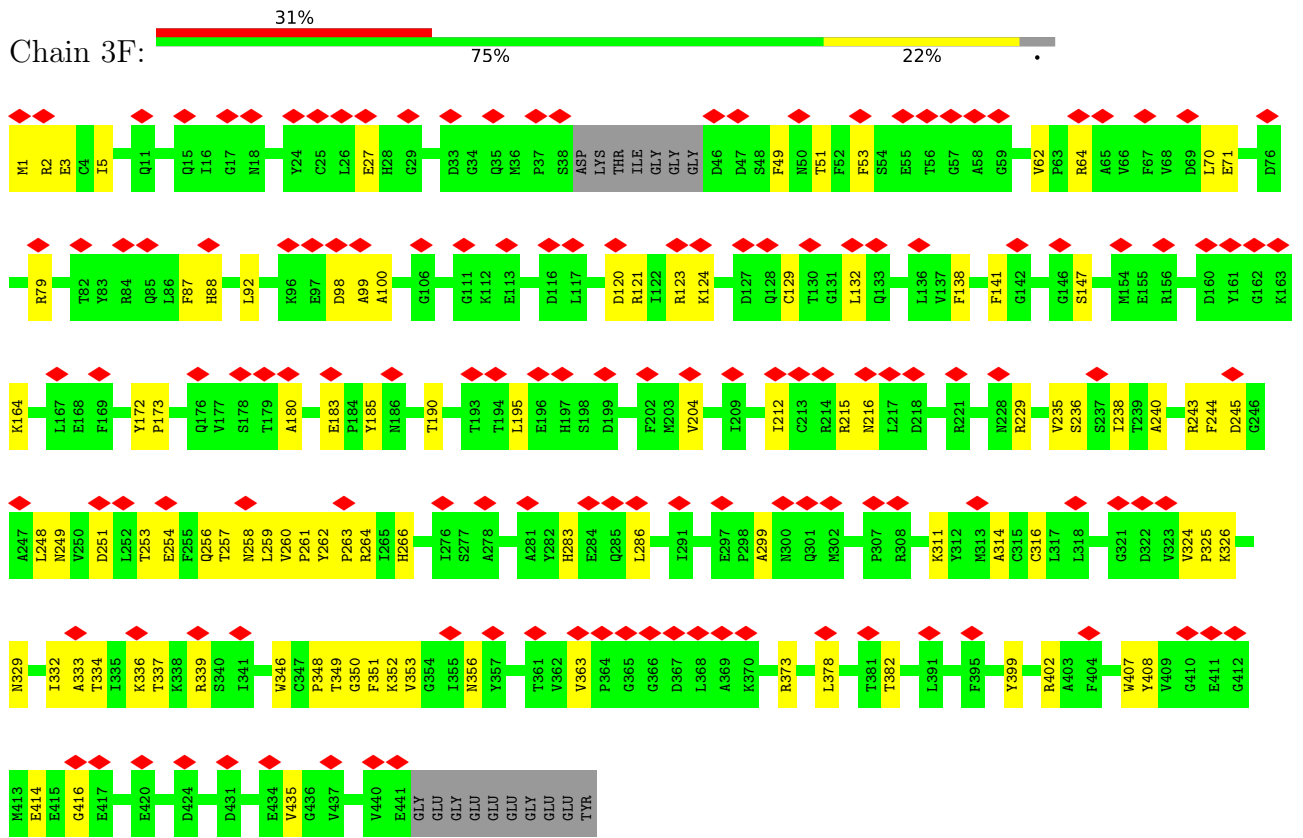

• Molecule 1: Tubulin alpha-1B chain

• Molecule 1: Tubulin alpha-1B chain

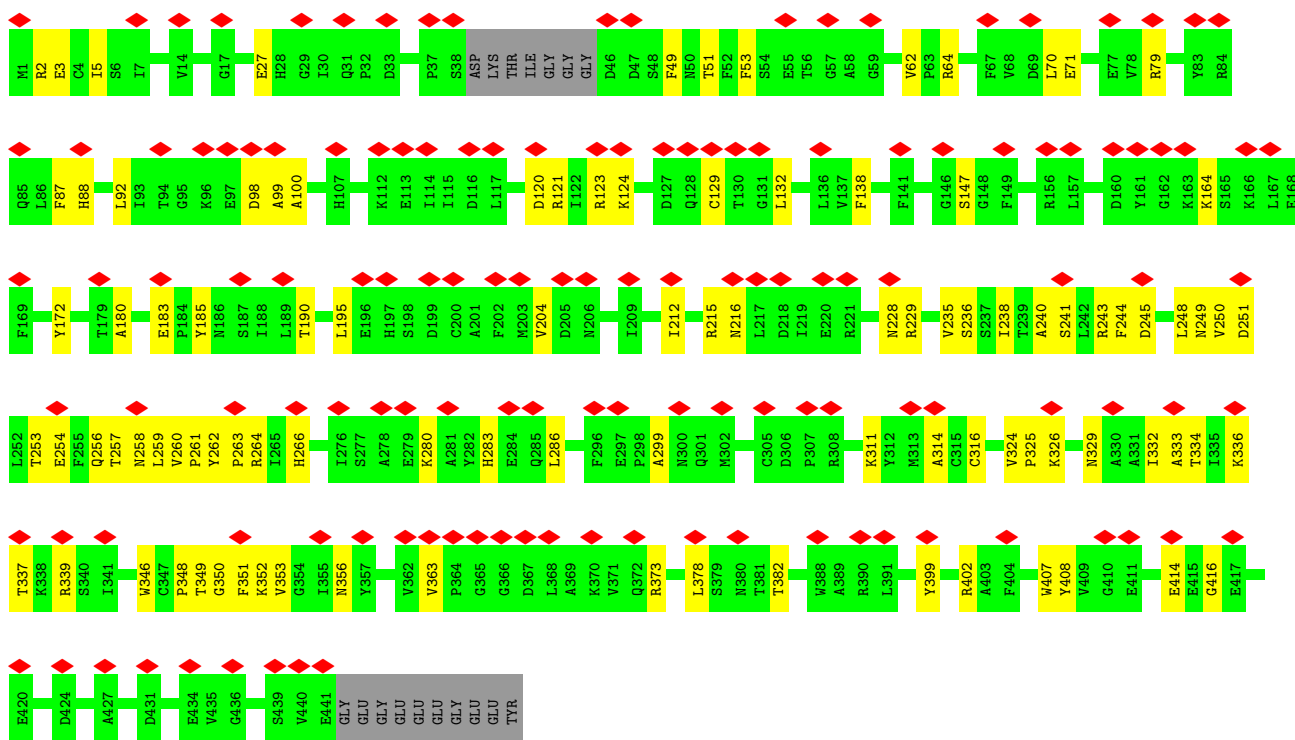
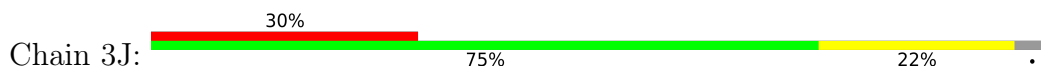

• Molecule 1: Tubulin alpha-1B chain

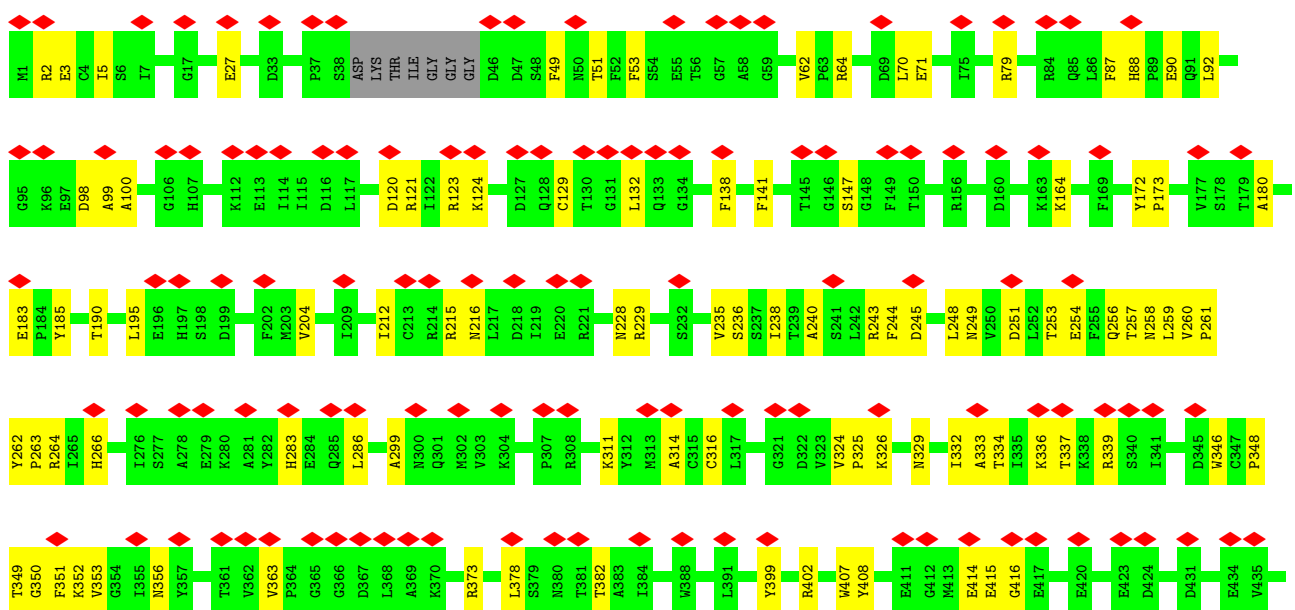
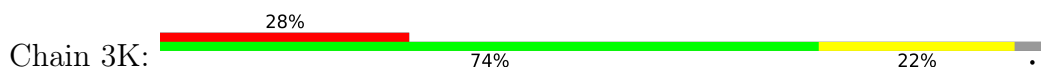

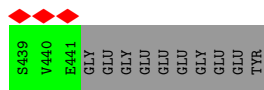

• Molecule 1: Tubulin alpha-1B chain

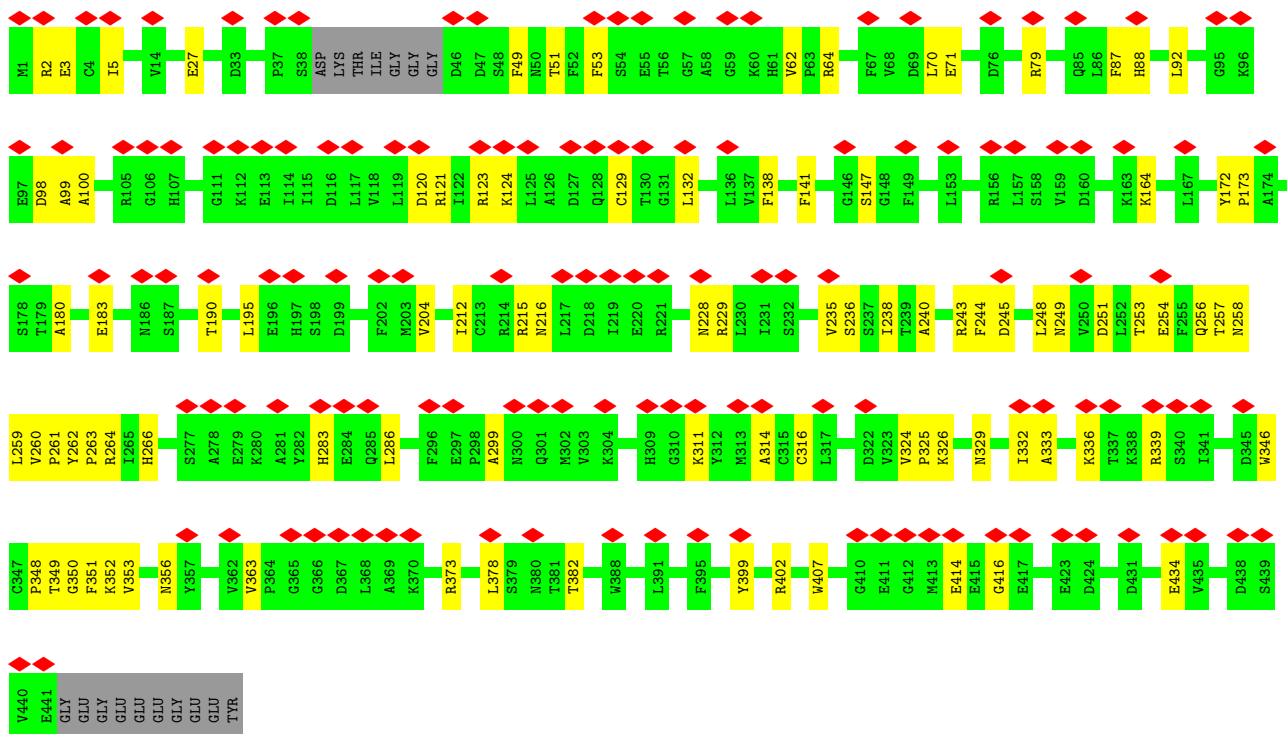
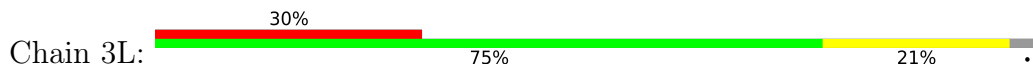

• Molecule 1: Tubulin alpha-1B chain

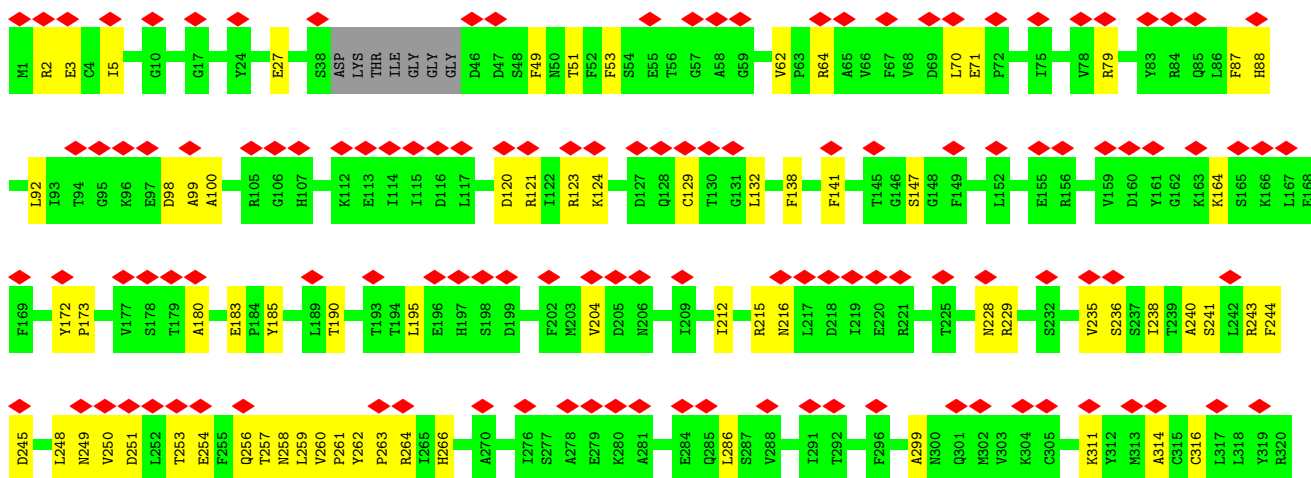
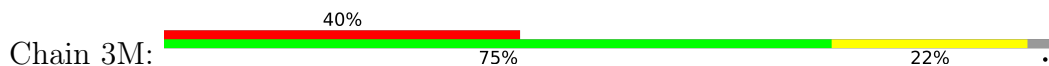

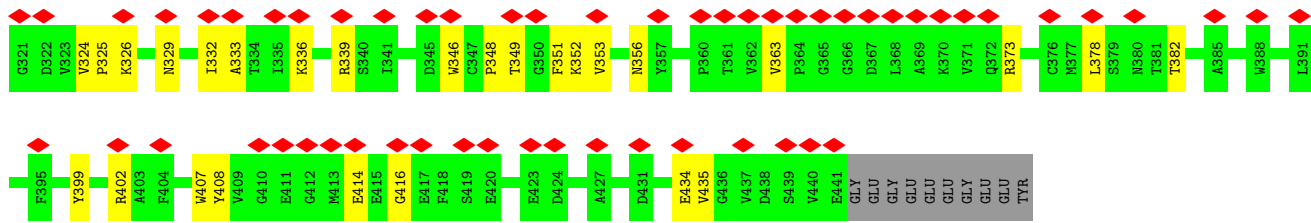

• Molecule 1: Tubulin alpha-1B chain

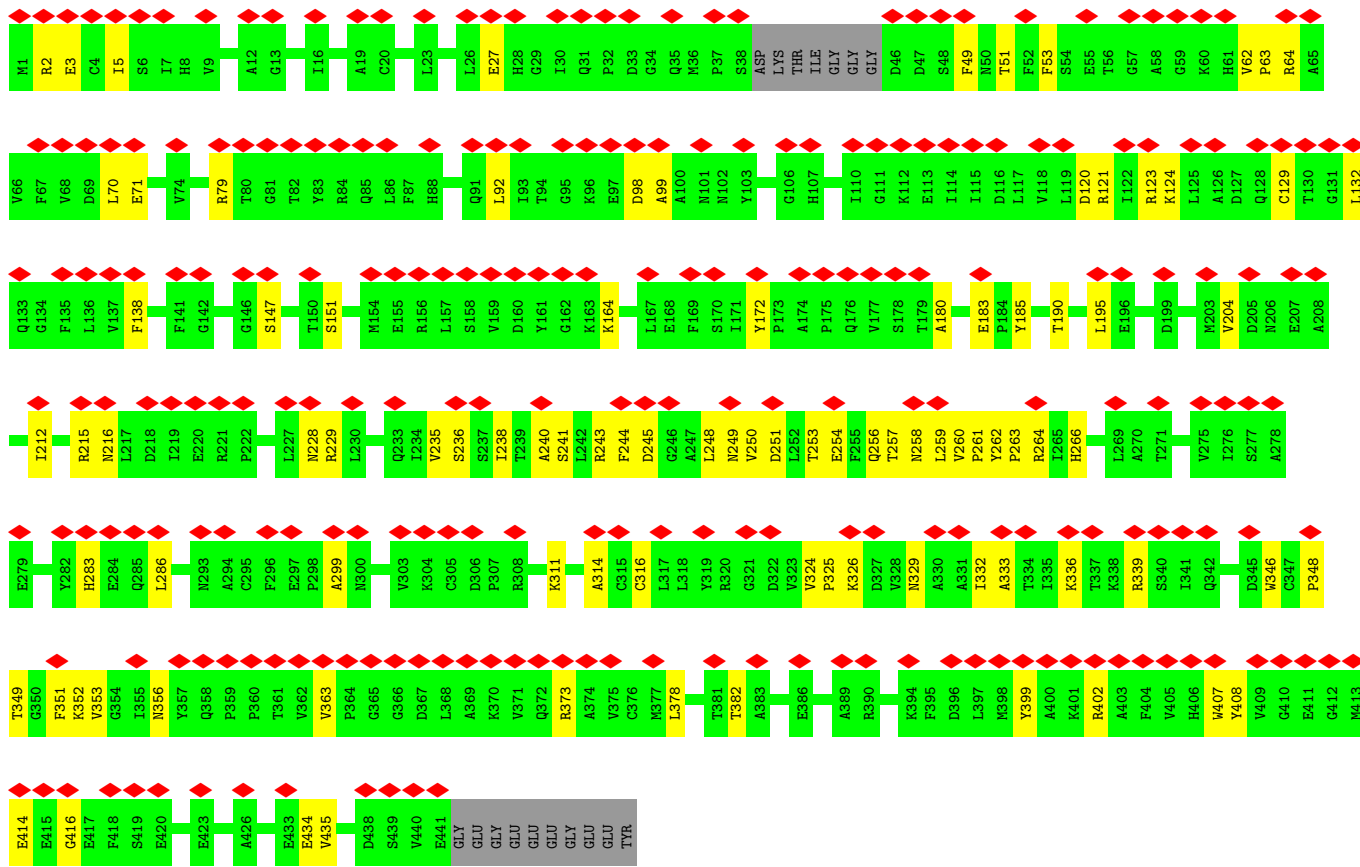
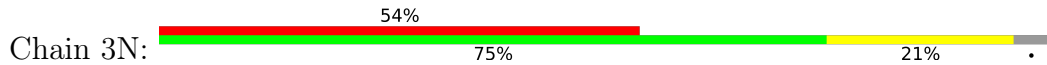

• Molecule 1: Tubulin alpha-1B chain

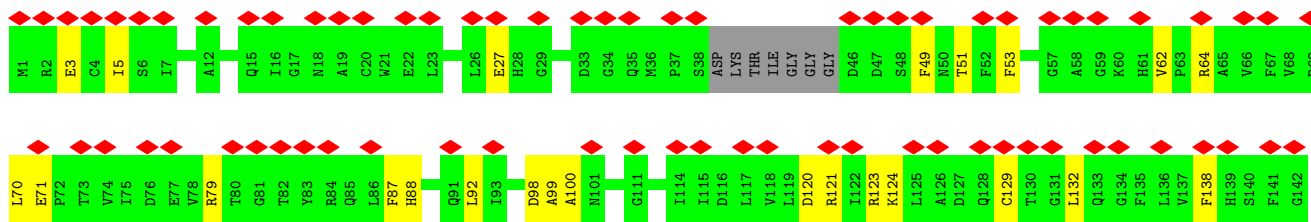
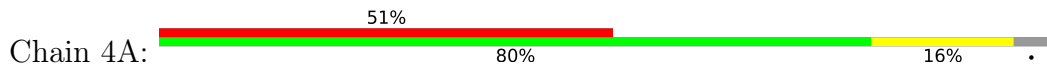

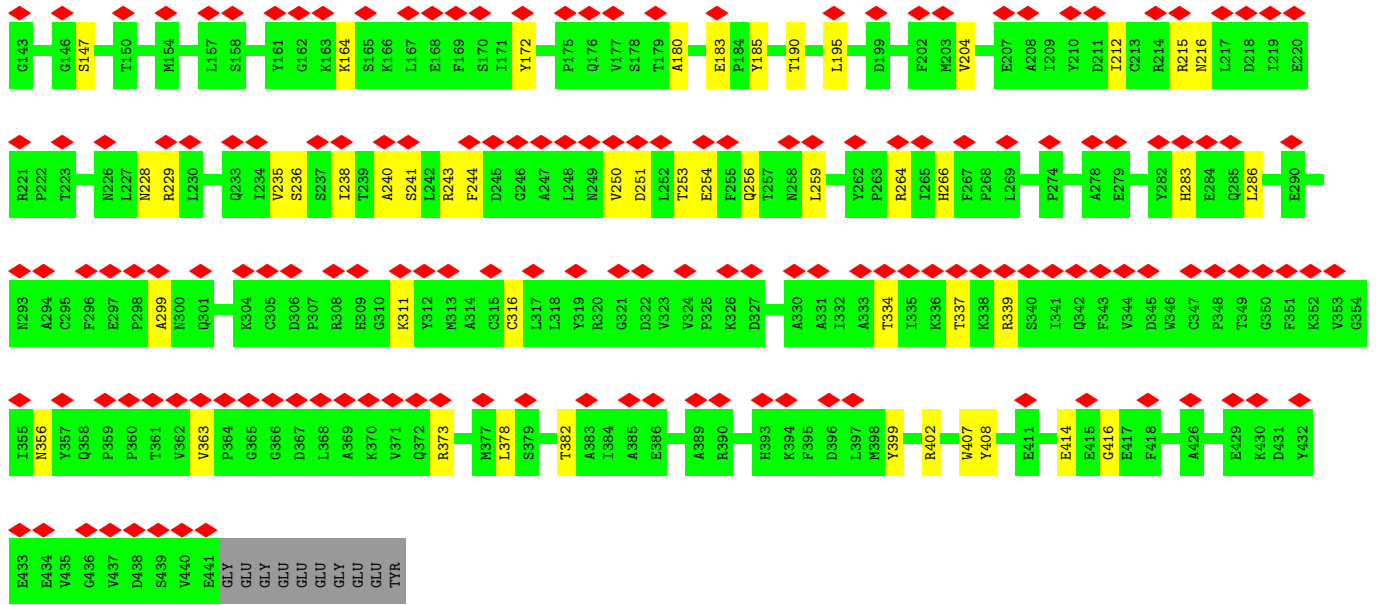

• Molecule 1: Tubulin alpha-1B chain

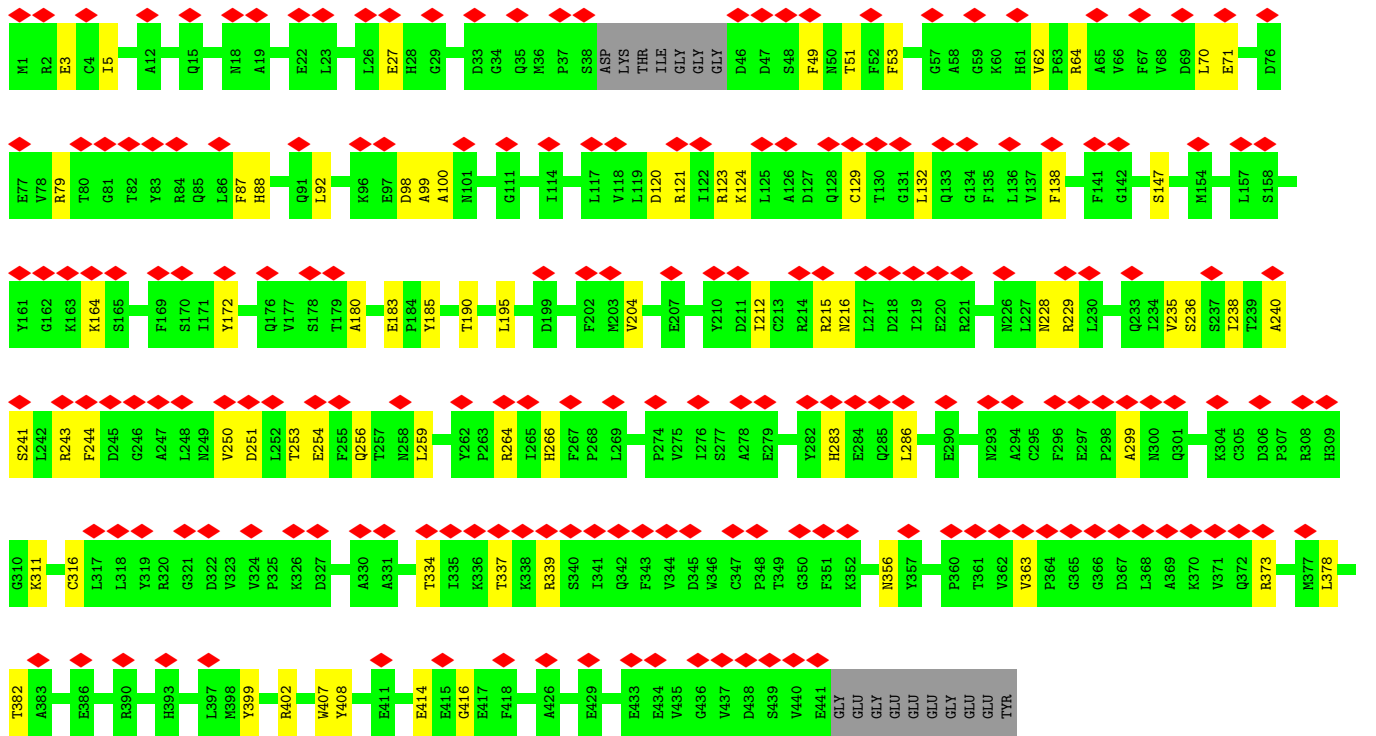
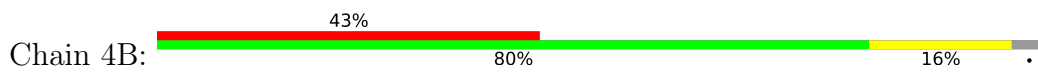

• Molecule 1: Tubulin alpha-1B chain

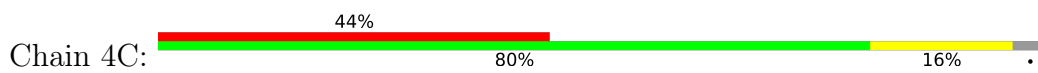

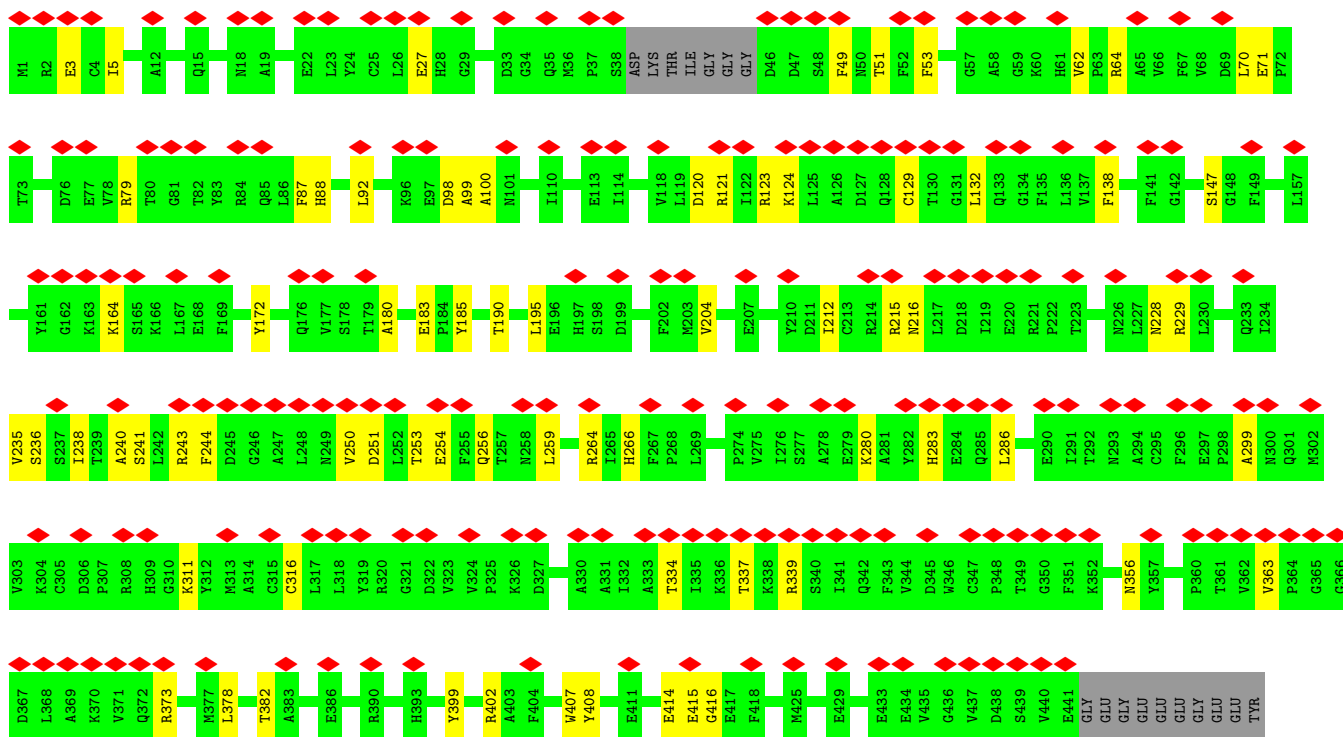

• Molecule 1: Tubulin alpha-1B chain

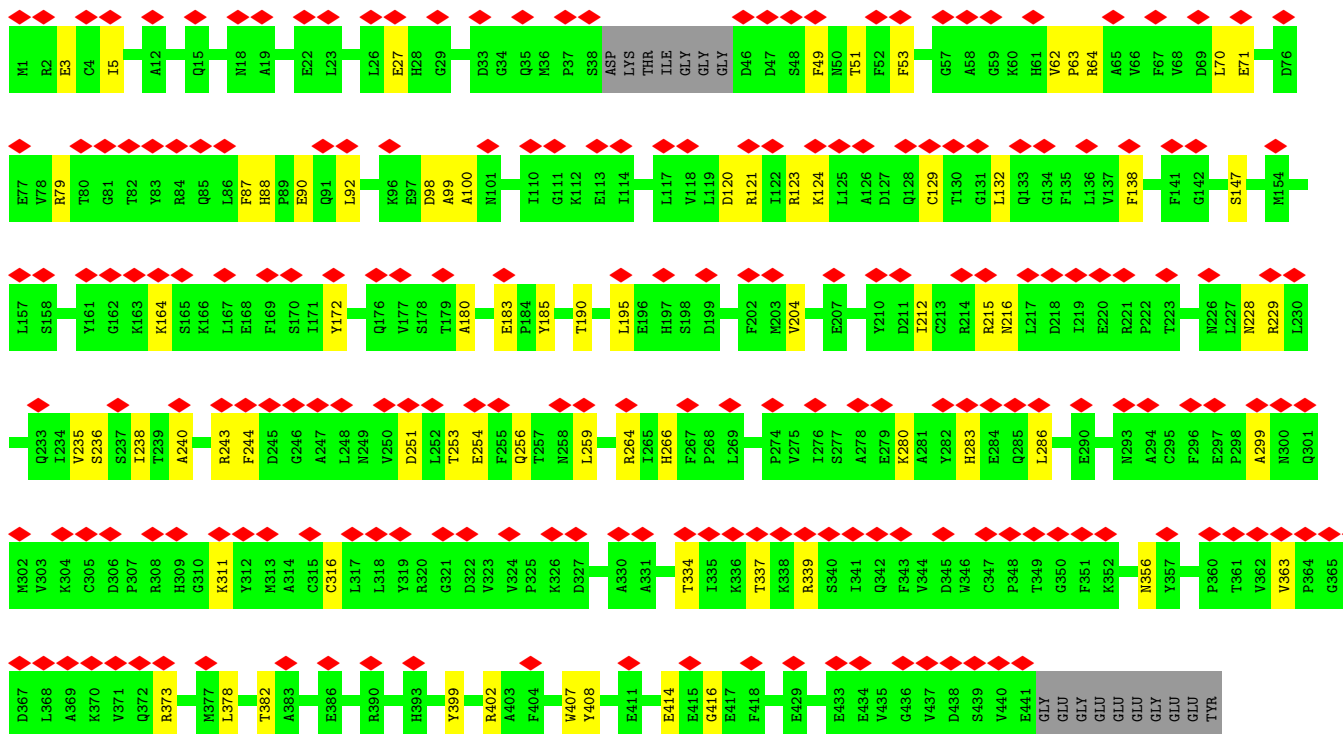
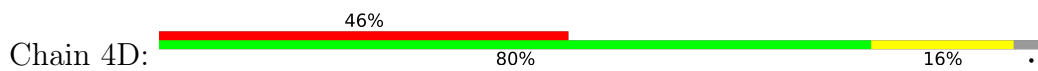

• Molecule 1: Tubulin alpha-1B chain

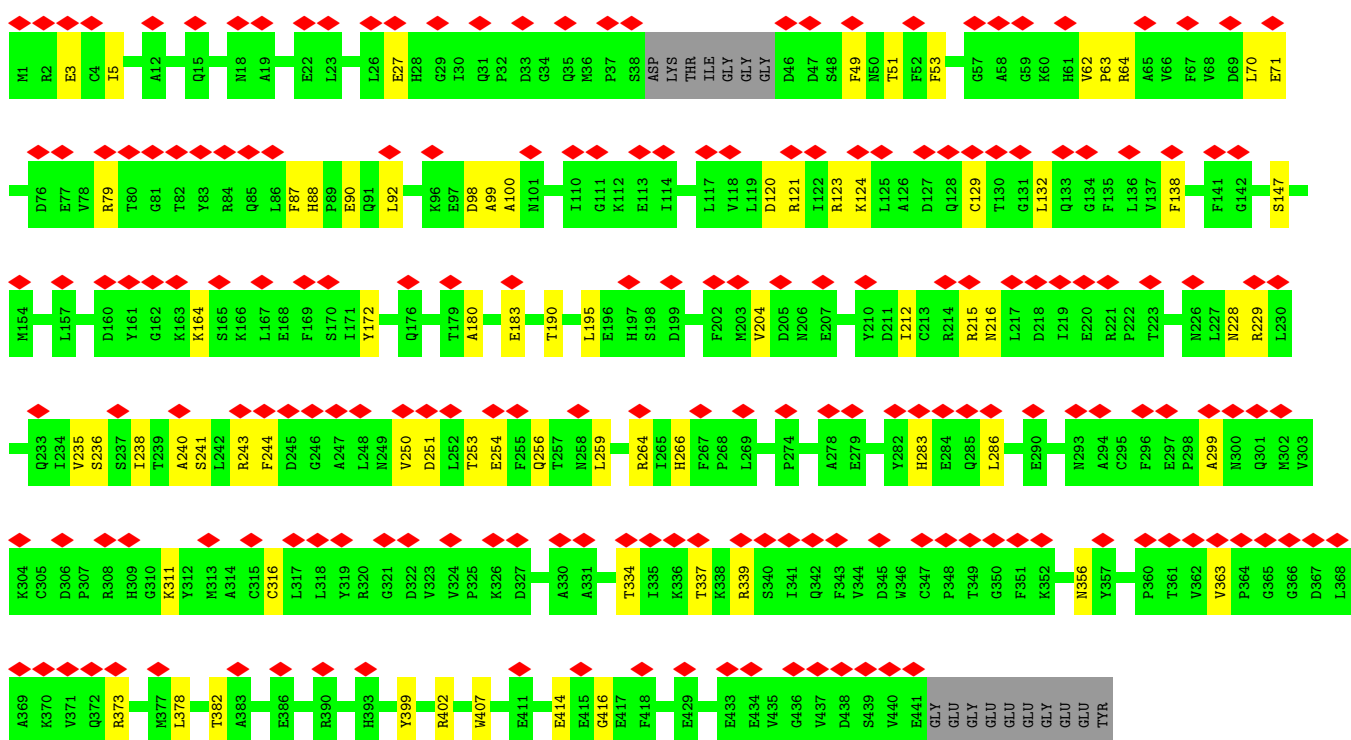
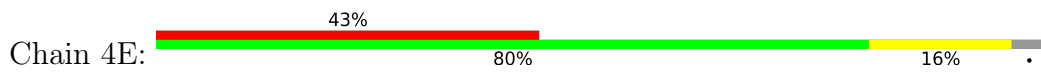

• Molecule 1: Tubulin alpha-1B chain

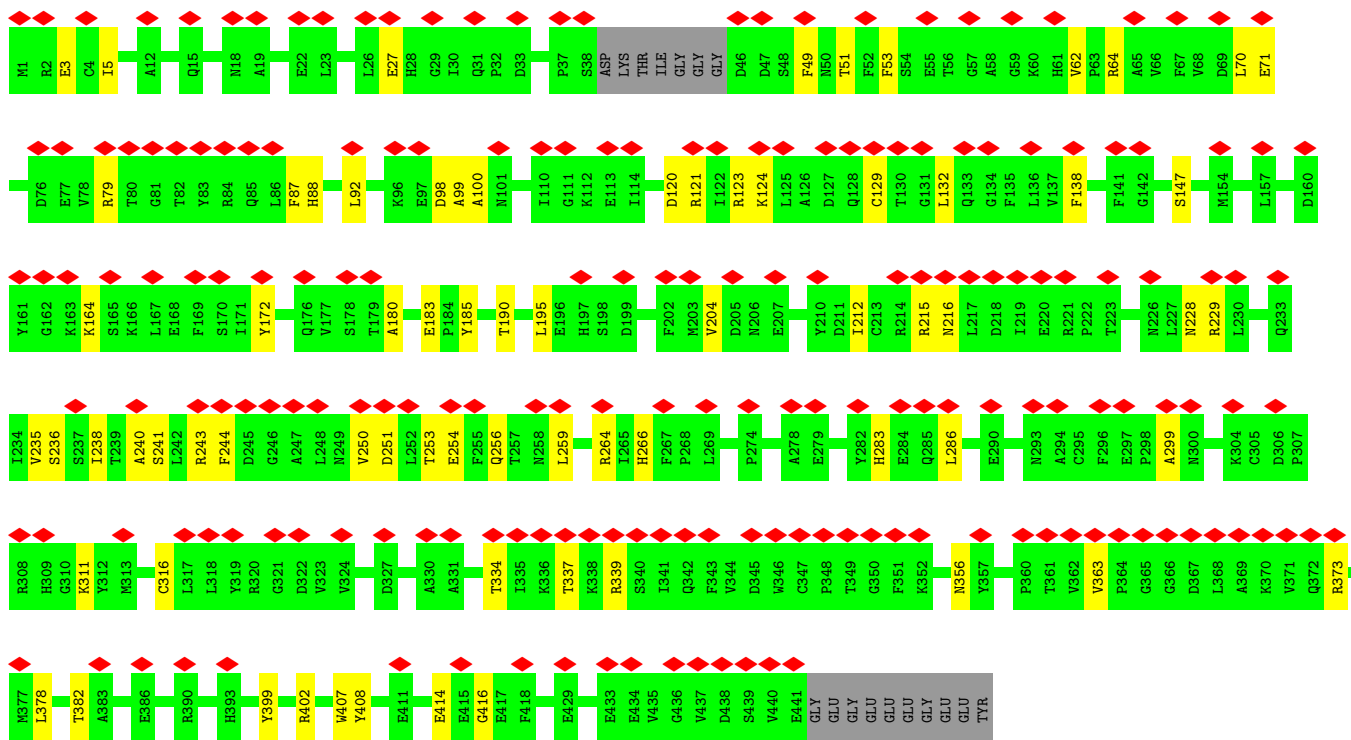
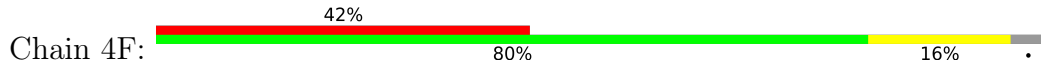

• Molecule 1: Tubulin alpha-1B chain

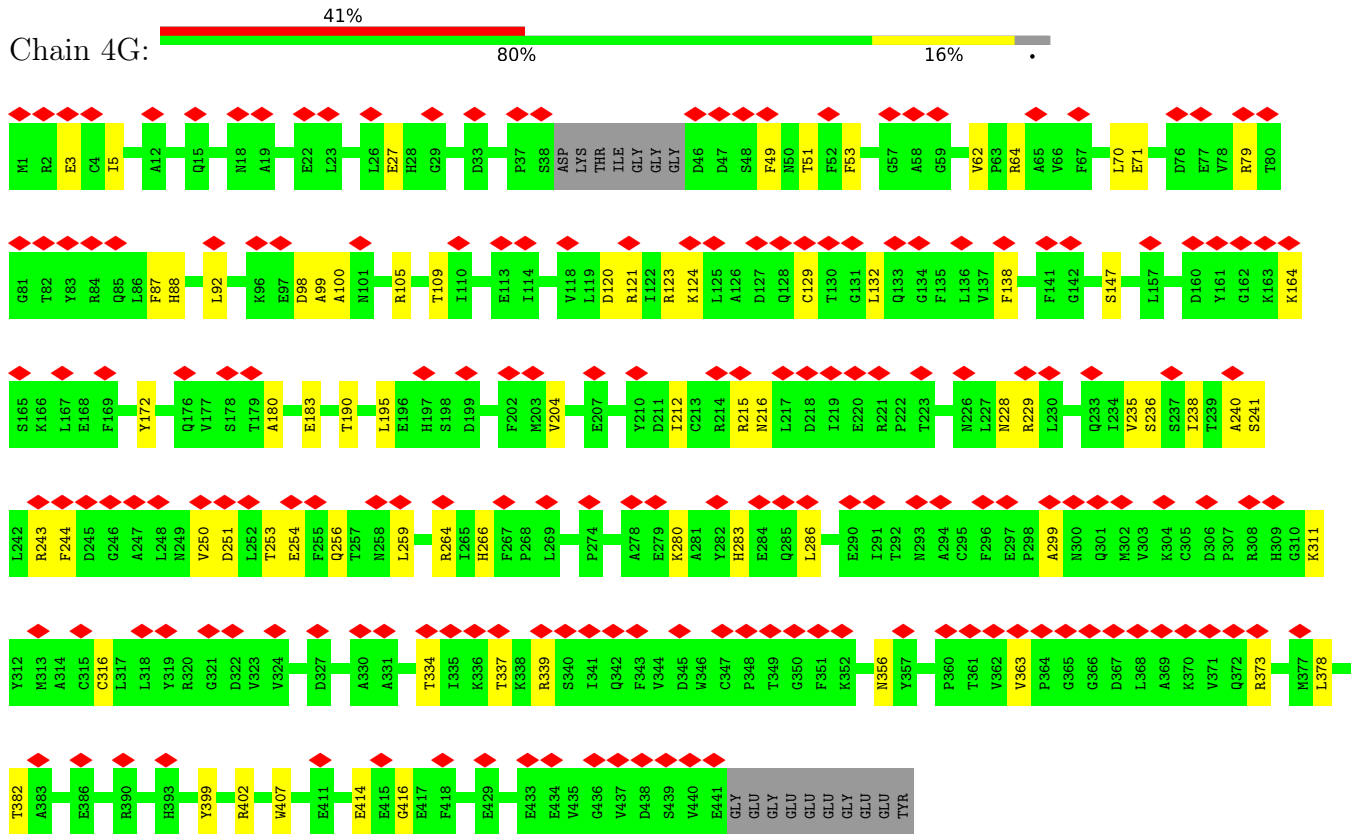

• Molecule 1: Tubulin alpha-1B chain

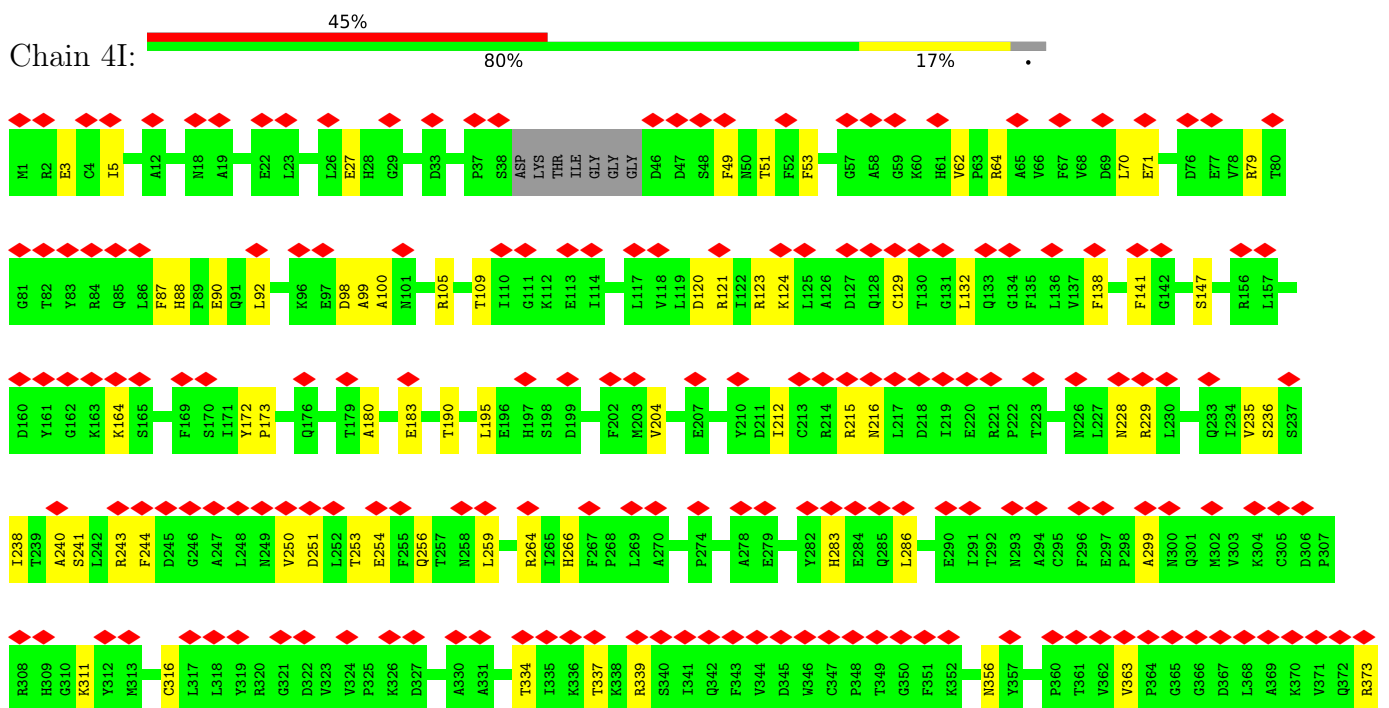

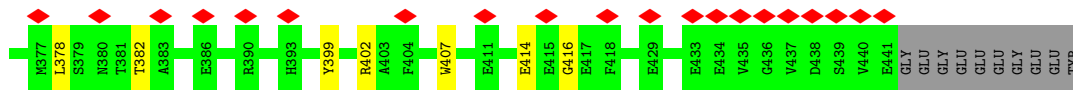

• Molecule 1: Tubulin alpha-1B chain

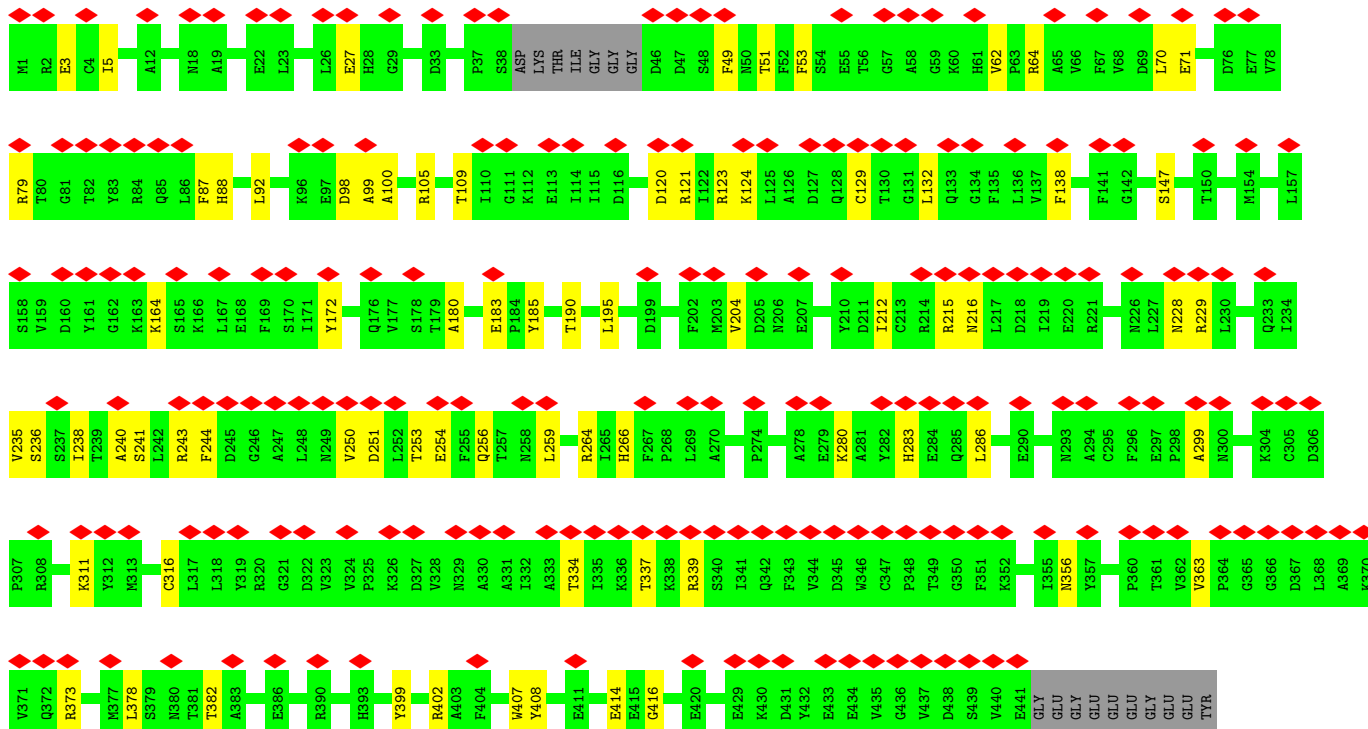
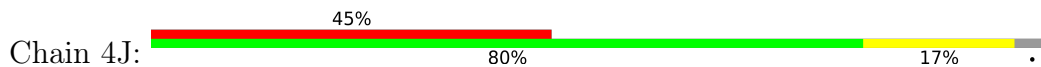

• Molecule 1: Tubulin alpha-1B chain

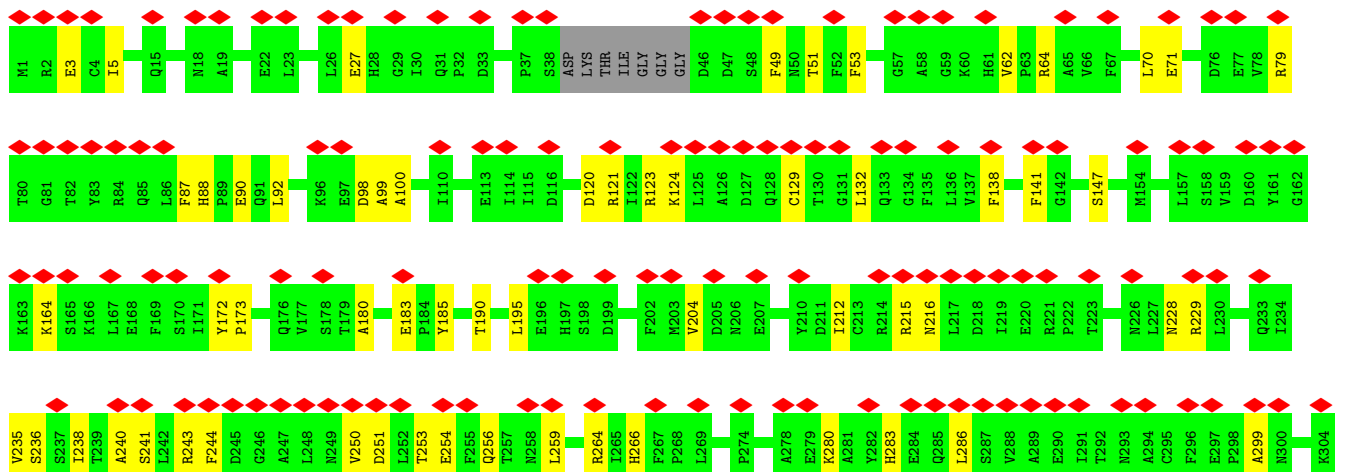
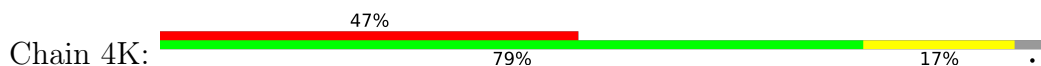

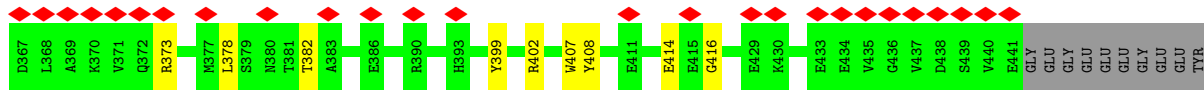
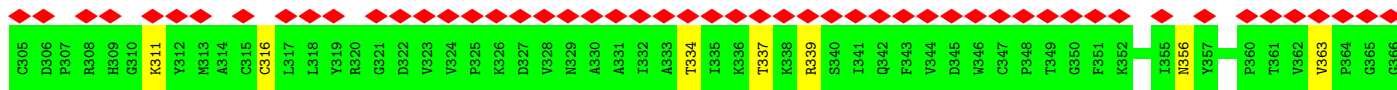

• Molecule 1: Tubulin alpha-1B chain

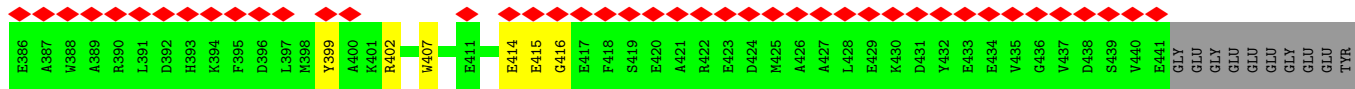
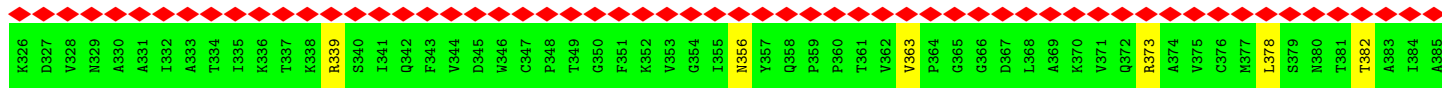
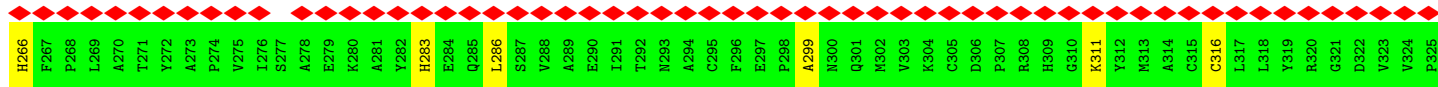
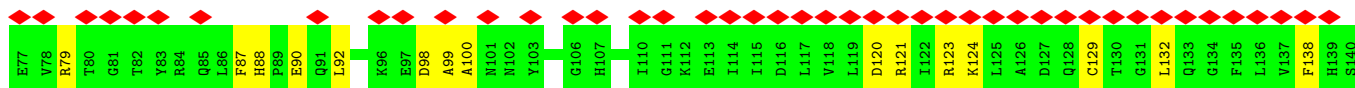
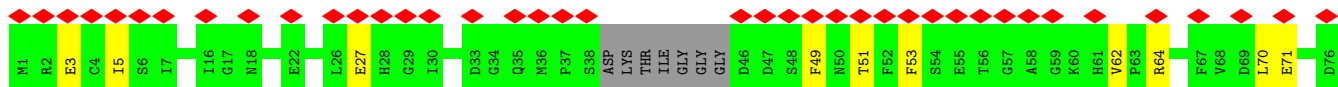
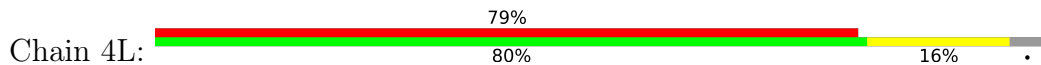

• Molecule 1: Tubulin alpha-1B chain

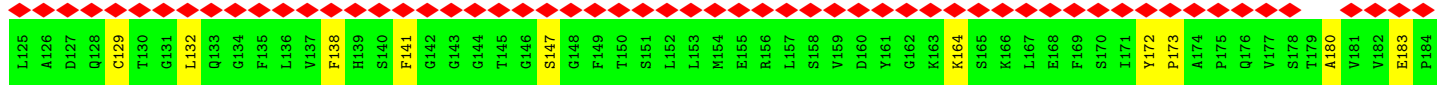
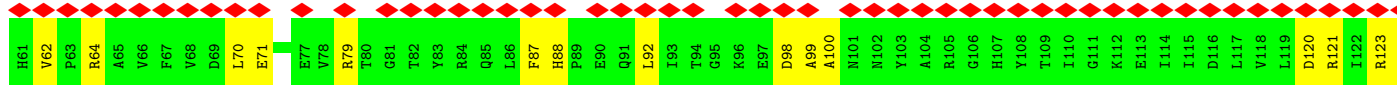
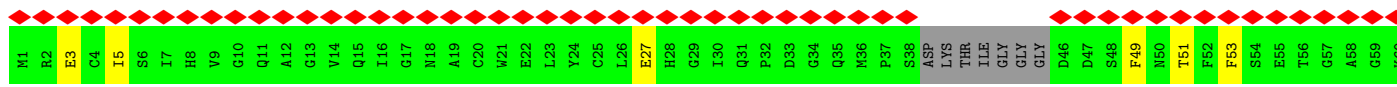
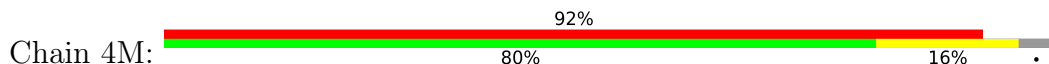



● Molecule 1: Tubulin alpha-1B chain

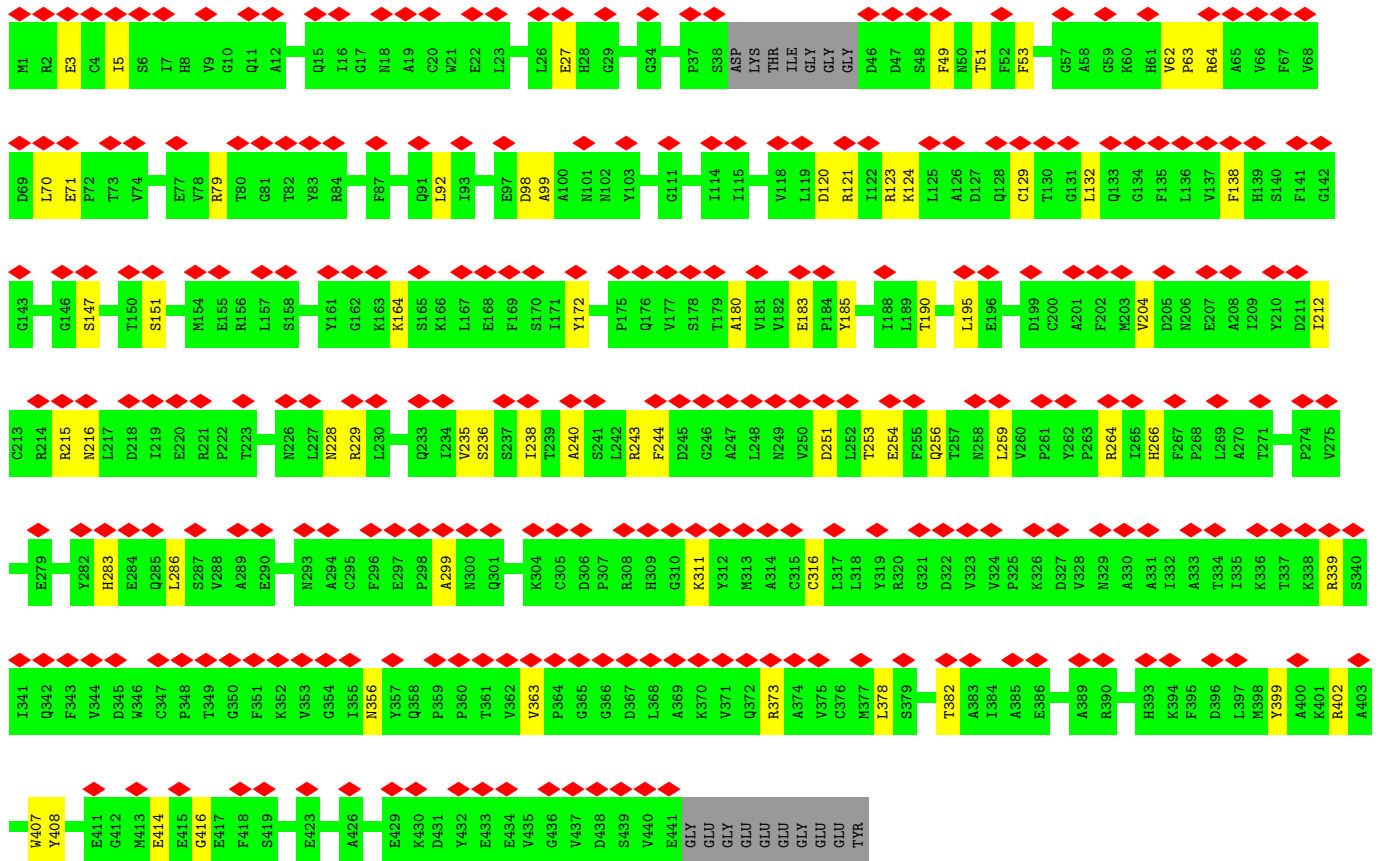
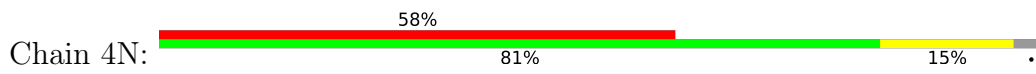

● Molecule 2: Tubulin beta chain

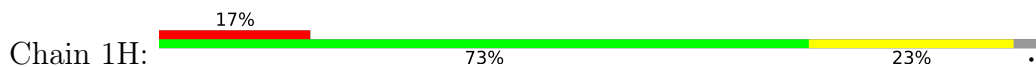

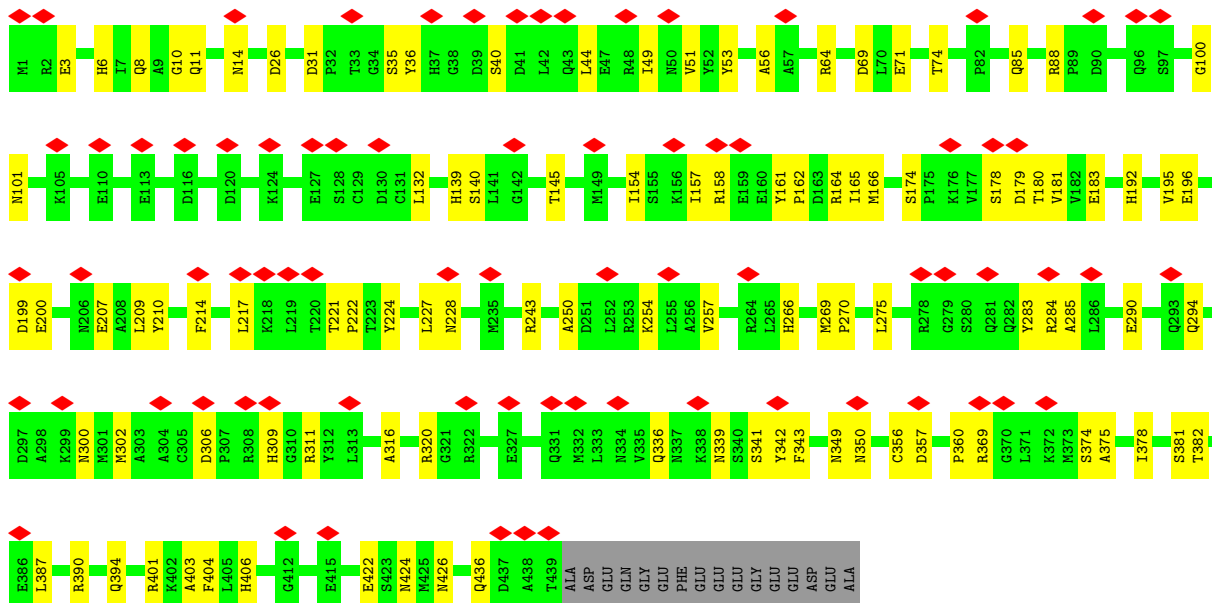

• Molecule 2: Tubulin beta chain

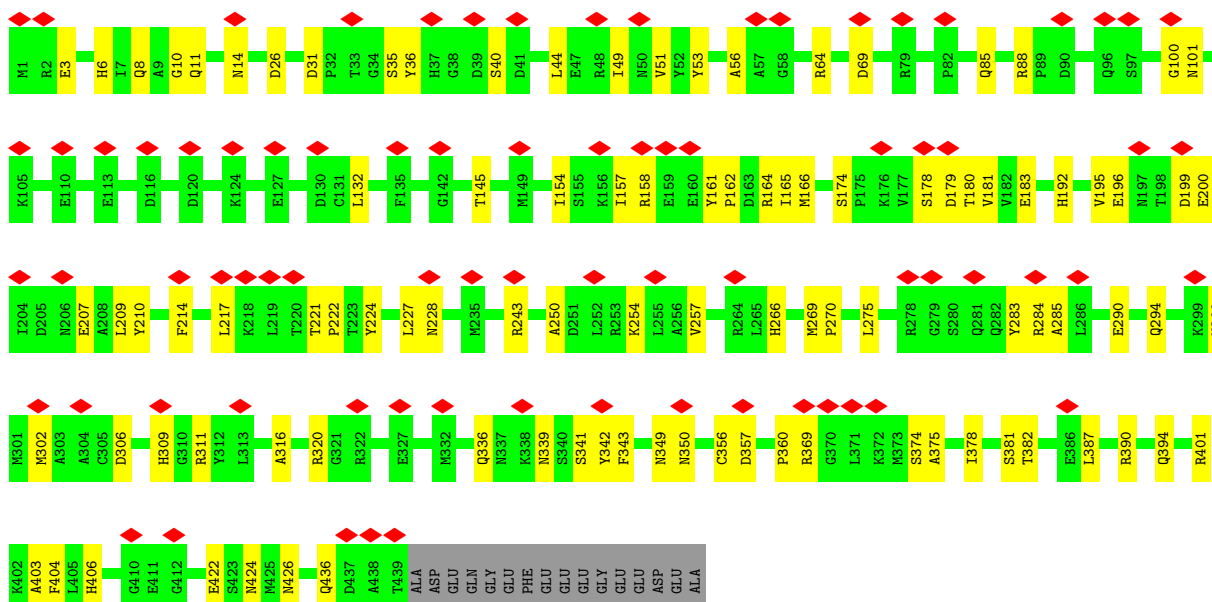
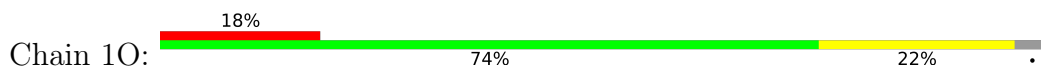

• Molecule 2: Tubulin beta chain

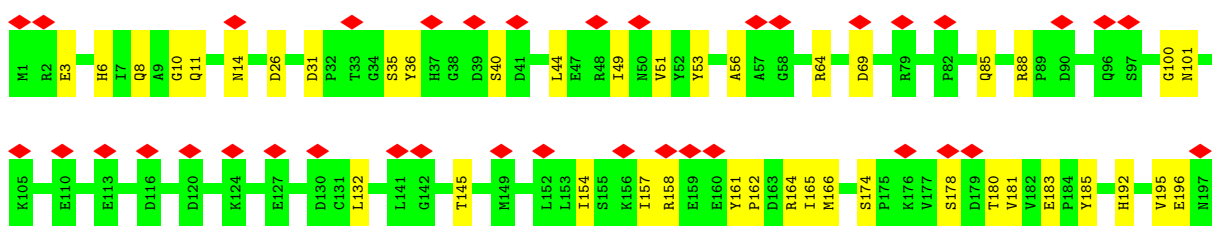
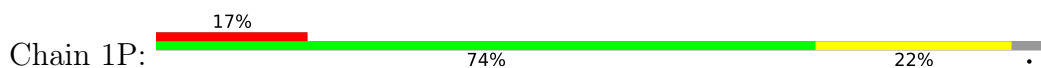

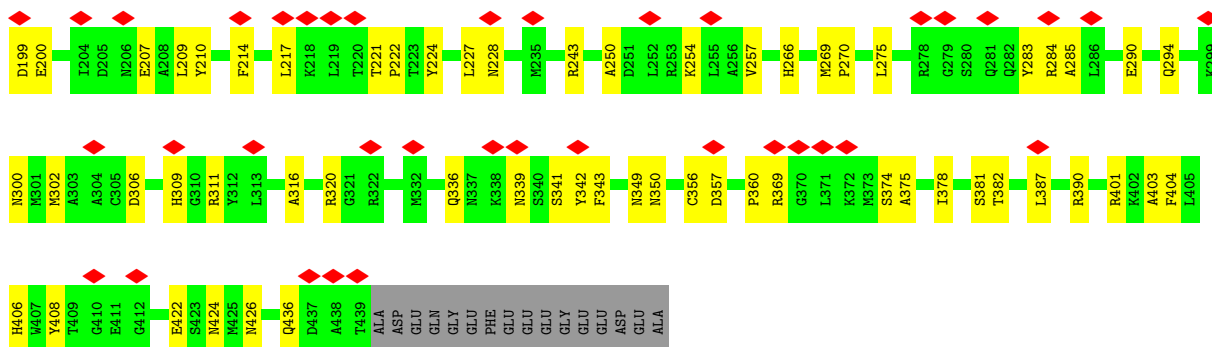

• Molecule 2: Tubulin beta chain

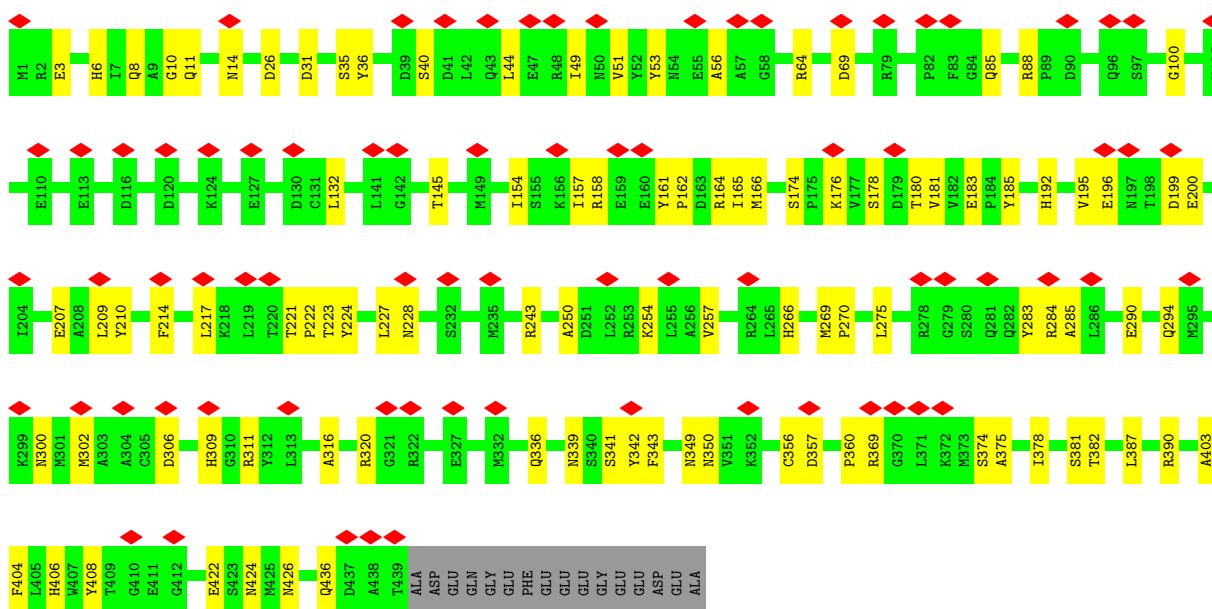
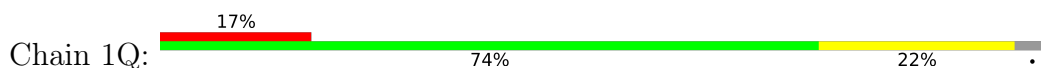

• Molecule 2: Tubulin beta chain

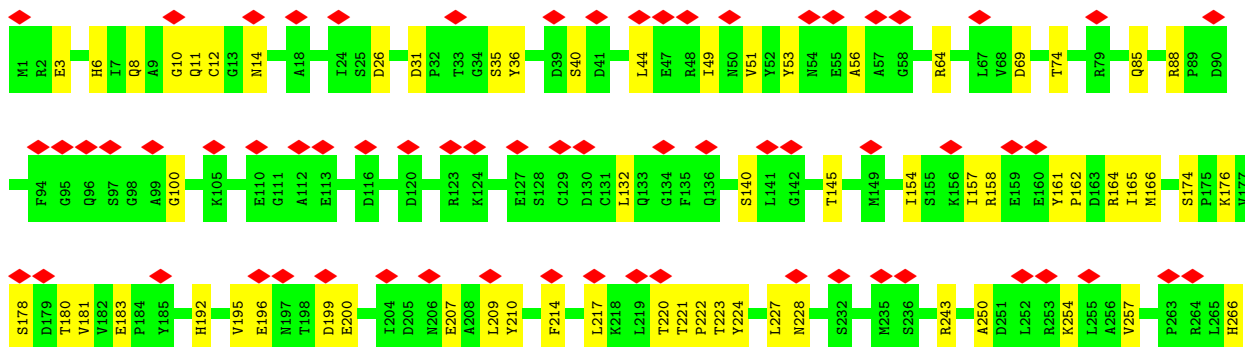
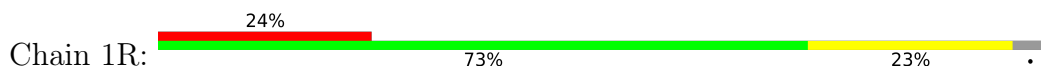

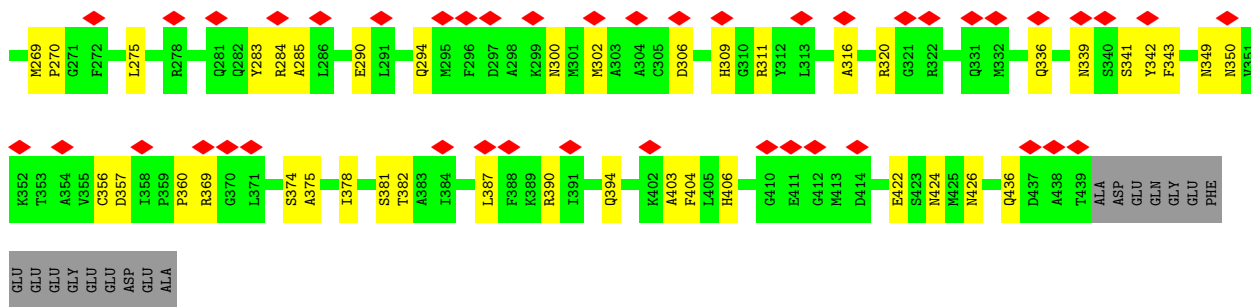

• Molecule 2: Tubulin beta chain

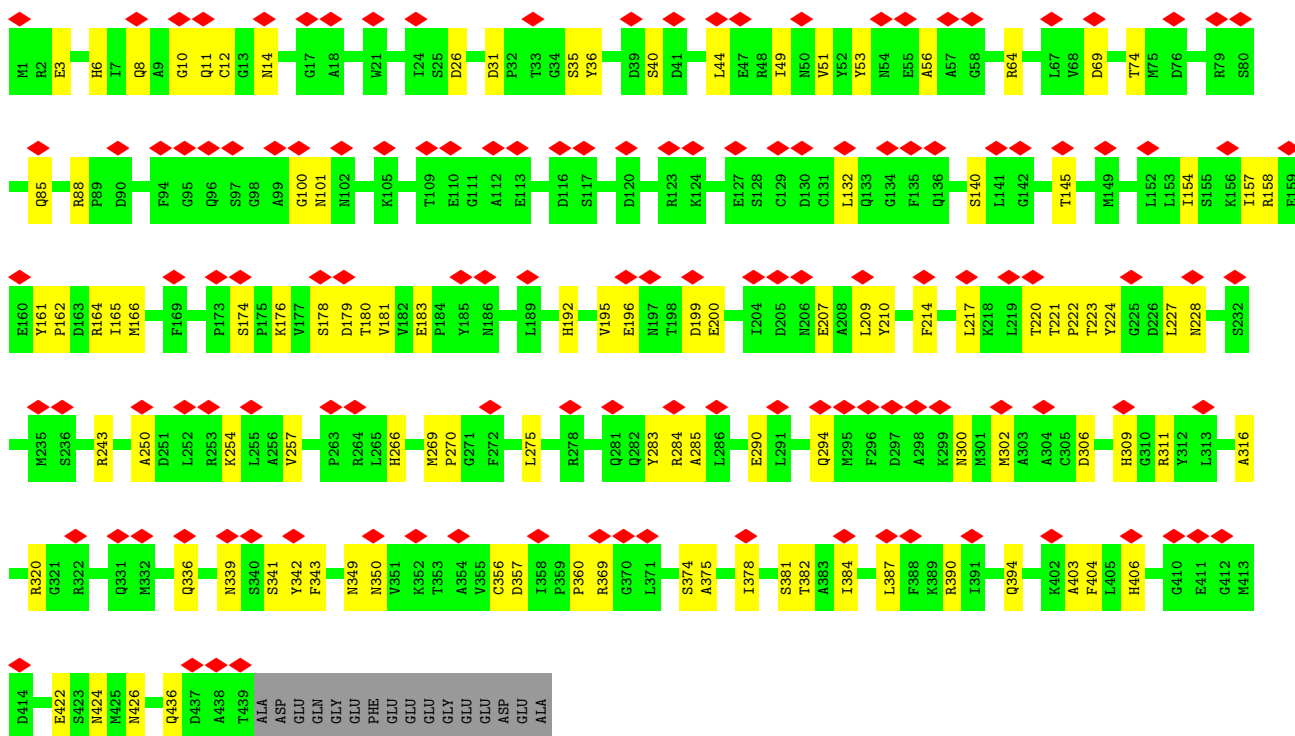

• Molecule 2: Tubulin beta chain

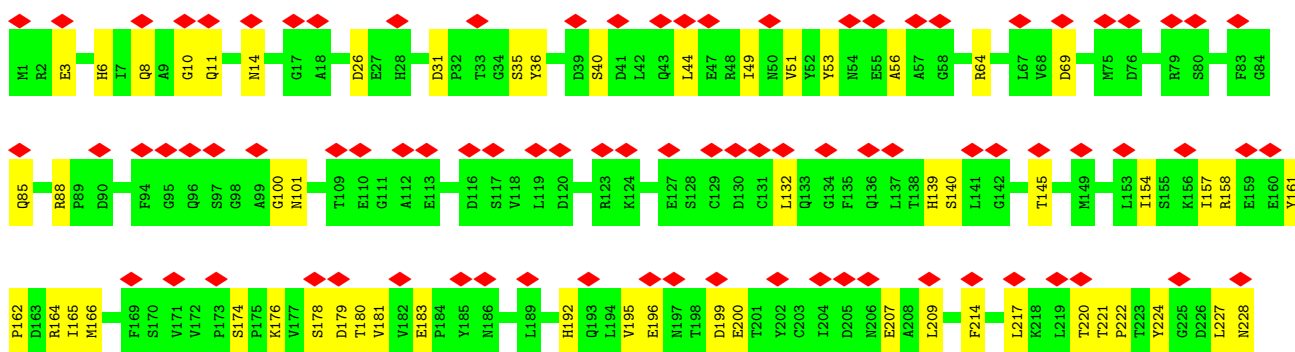
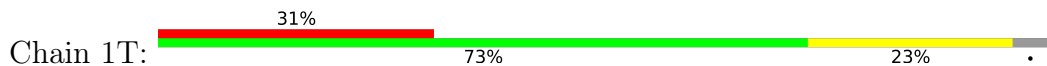

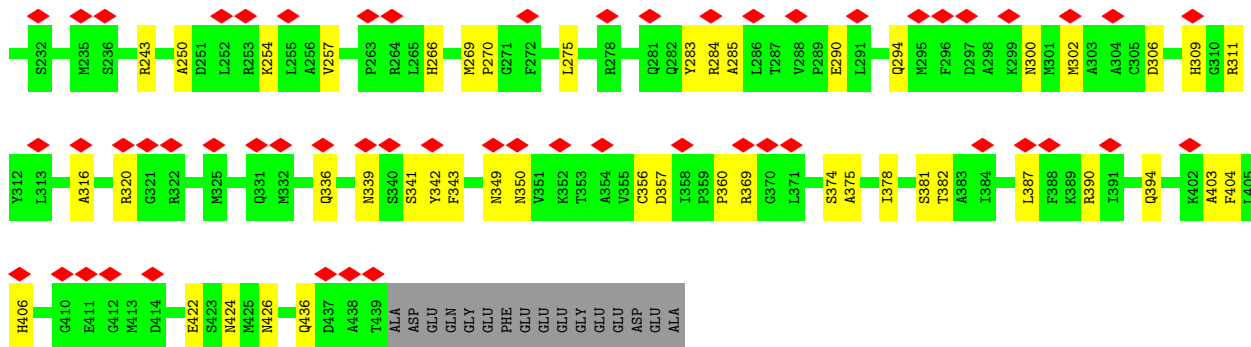

• Molecule 2: Tubulin beta chain

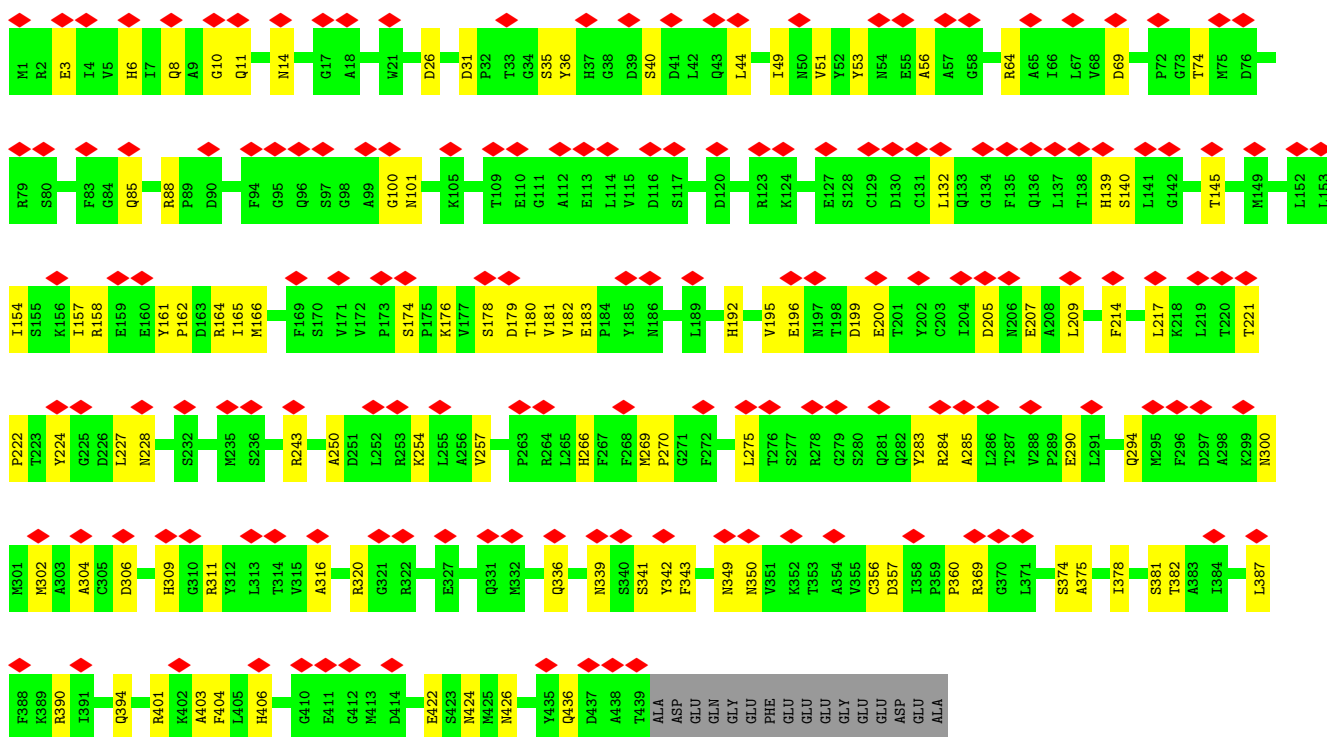
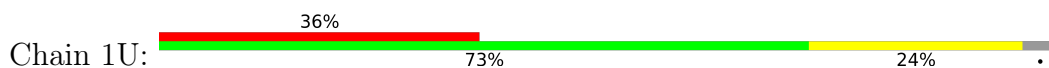

• Molecule 2: Tubulin beta chain

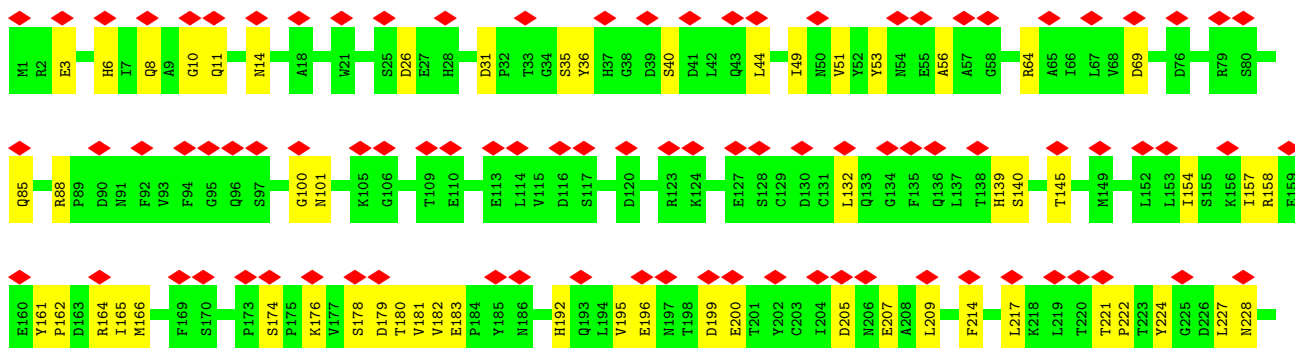
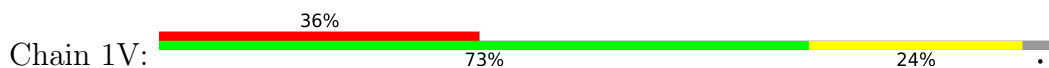

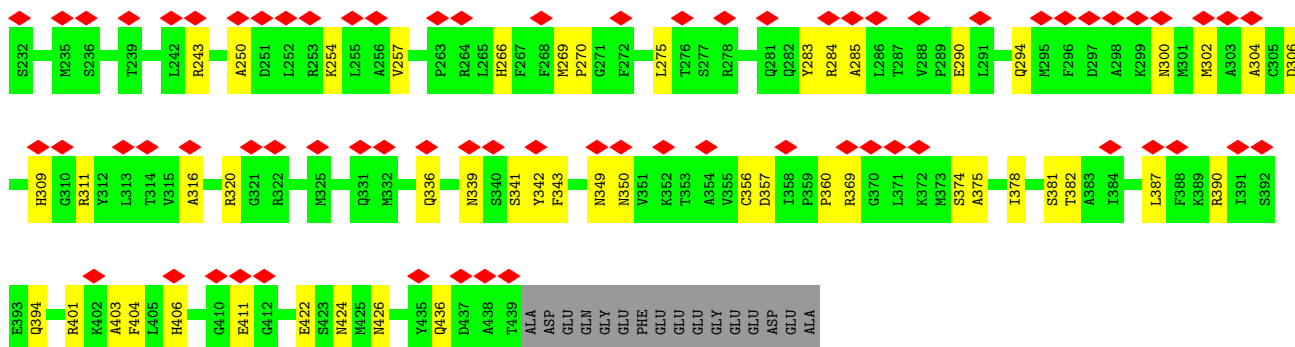

• Molecule 2: Tubulin beta chain

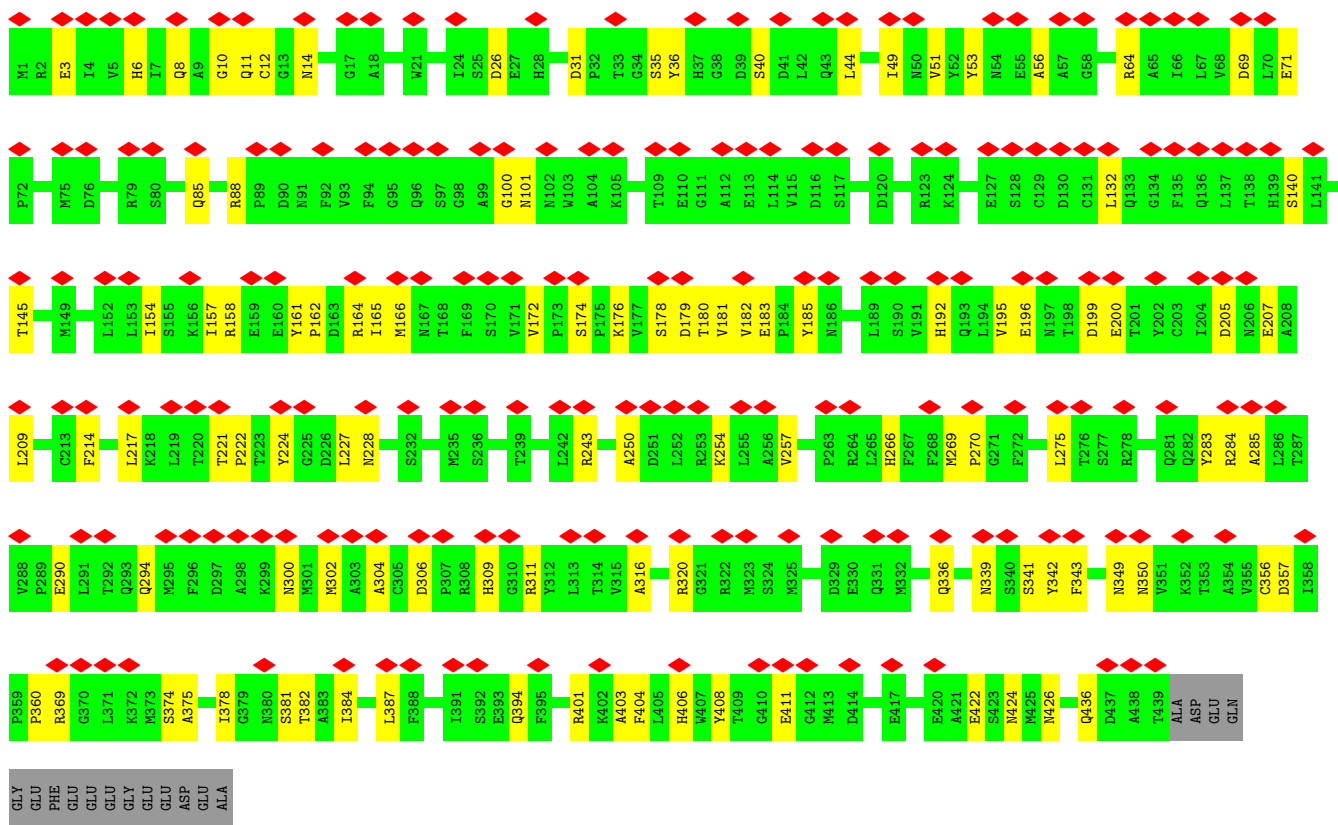
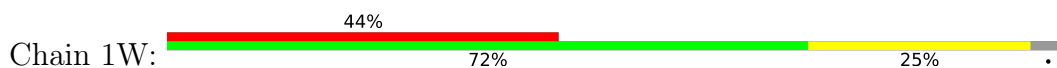

• Molecule 2: Tubulin beta chain

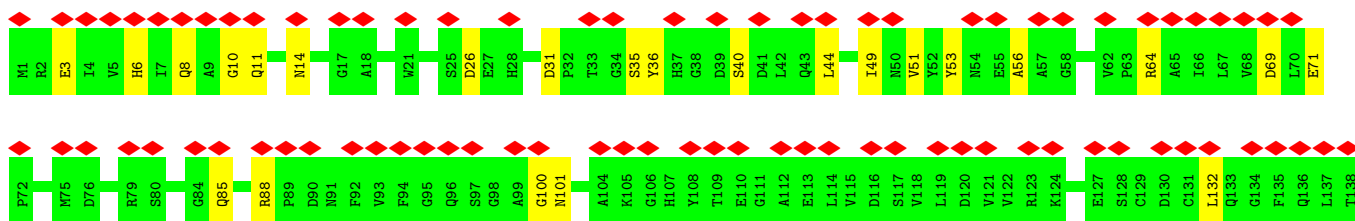



• Molecule 2: Tubulin beta chain

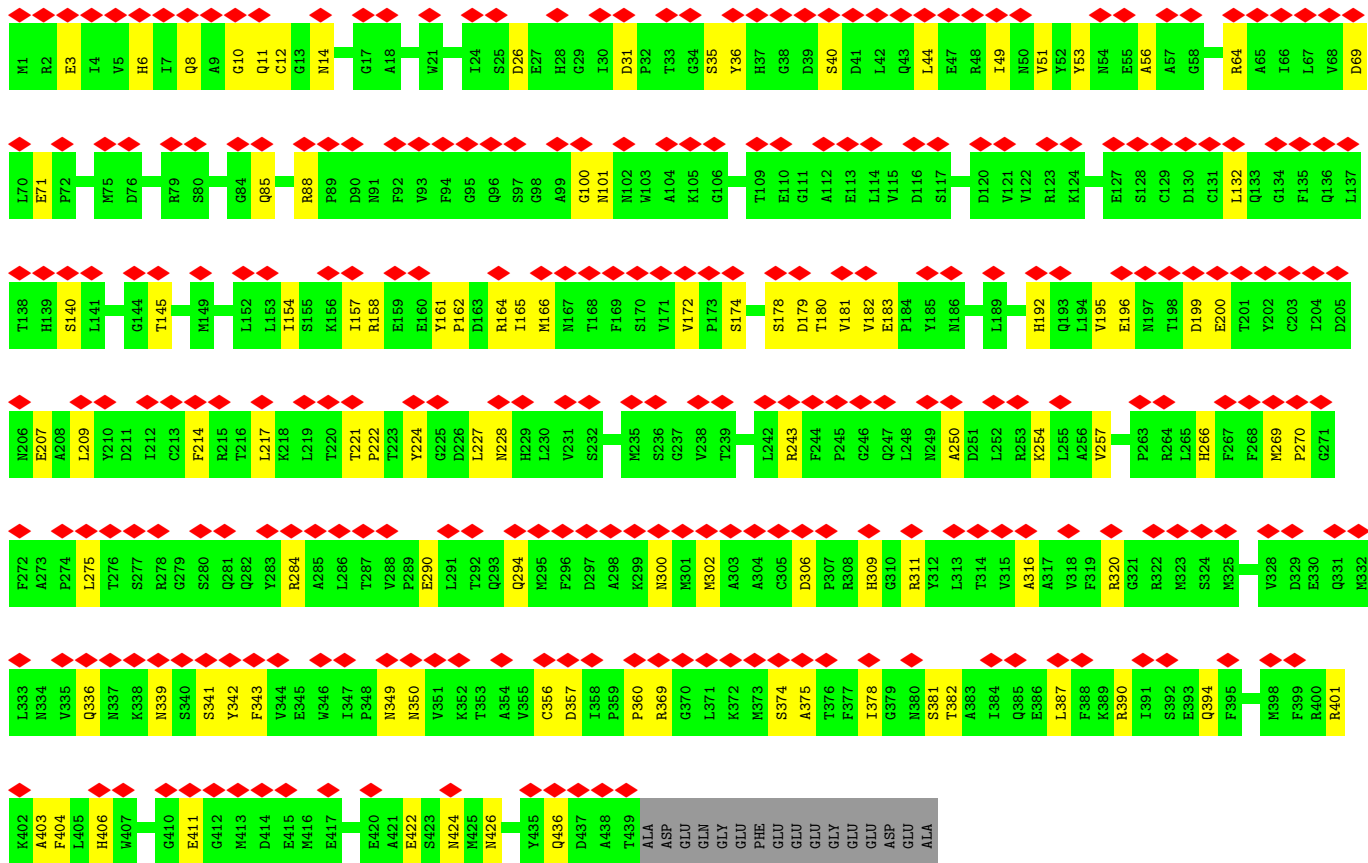
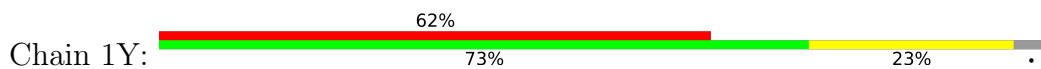

• Molecule 2: Tubulin beta chain

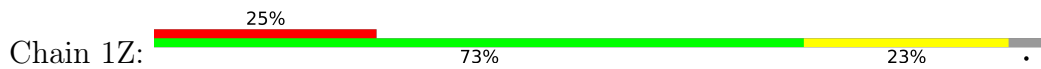

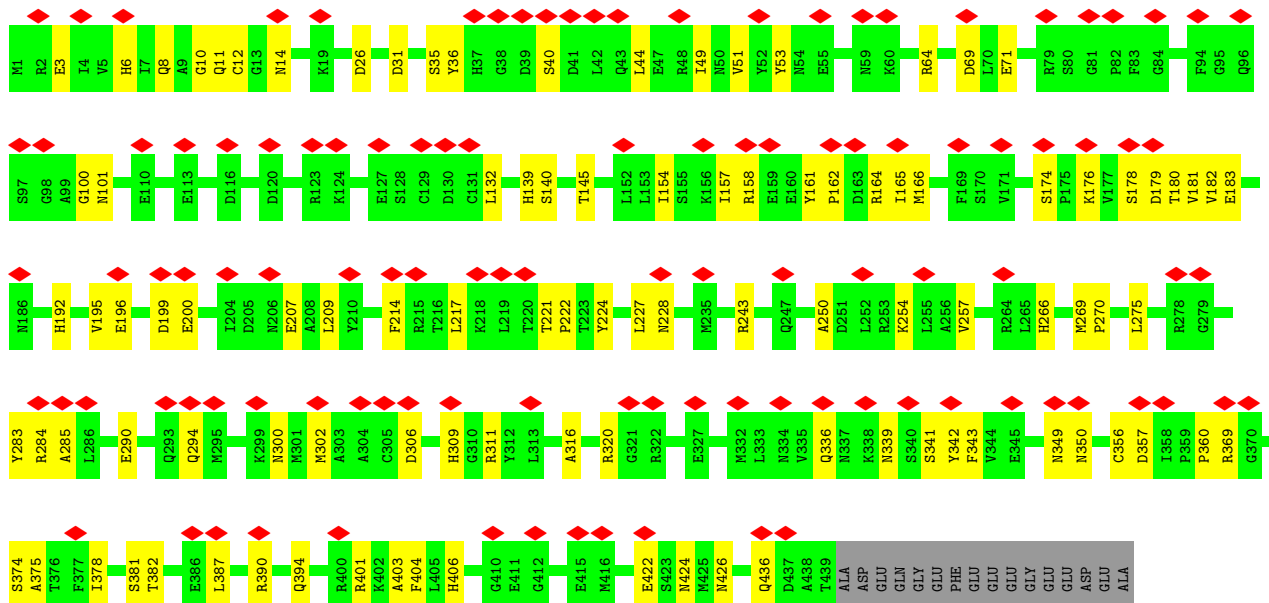

• Molecule 2: Tubulin beta chain

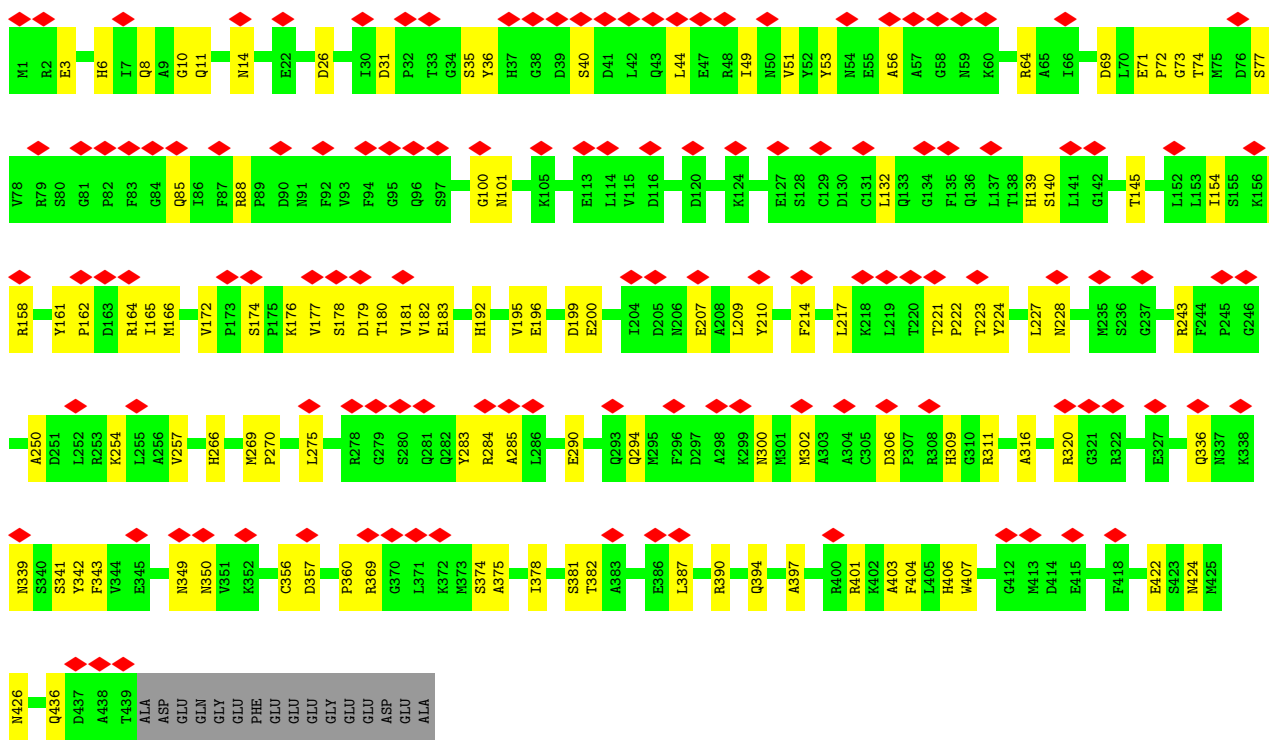

• Molecule 2: Tubulin beta chain

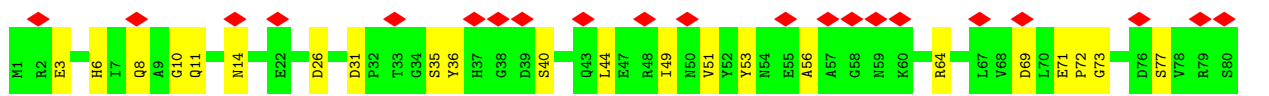

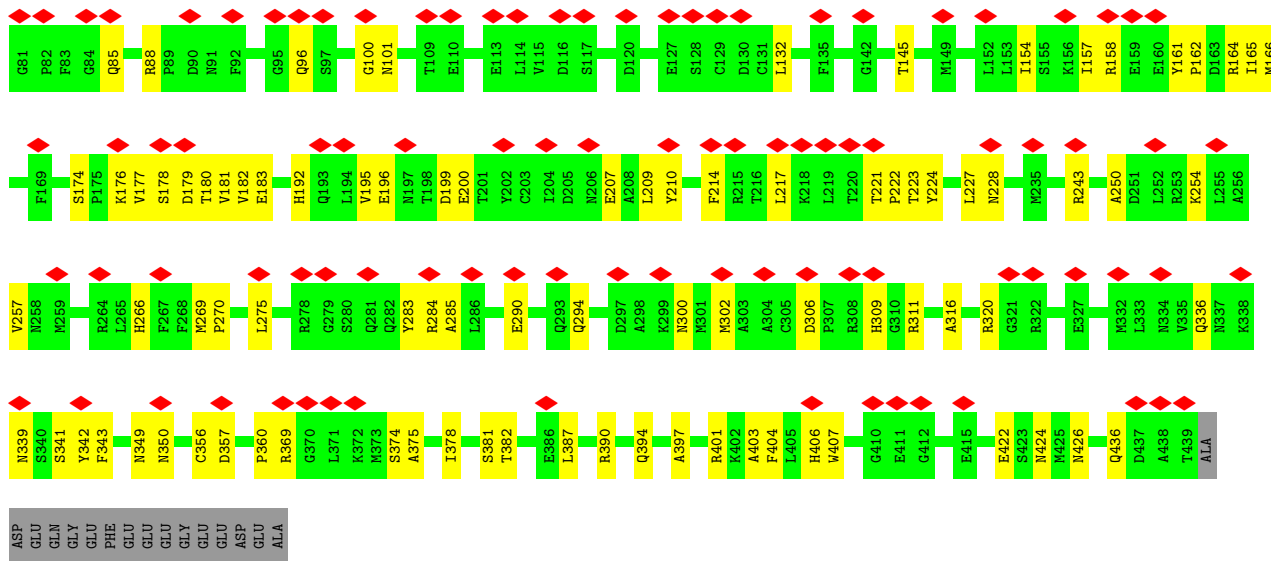

• Molecule 2: Tubulin beta chain

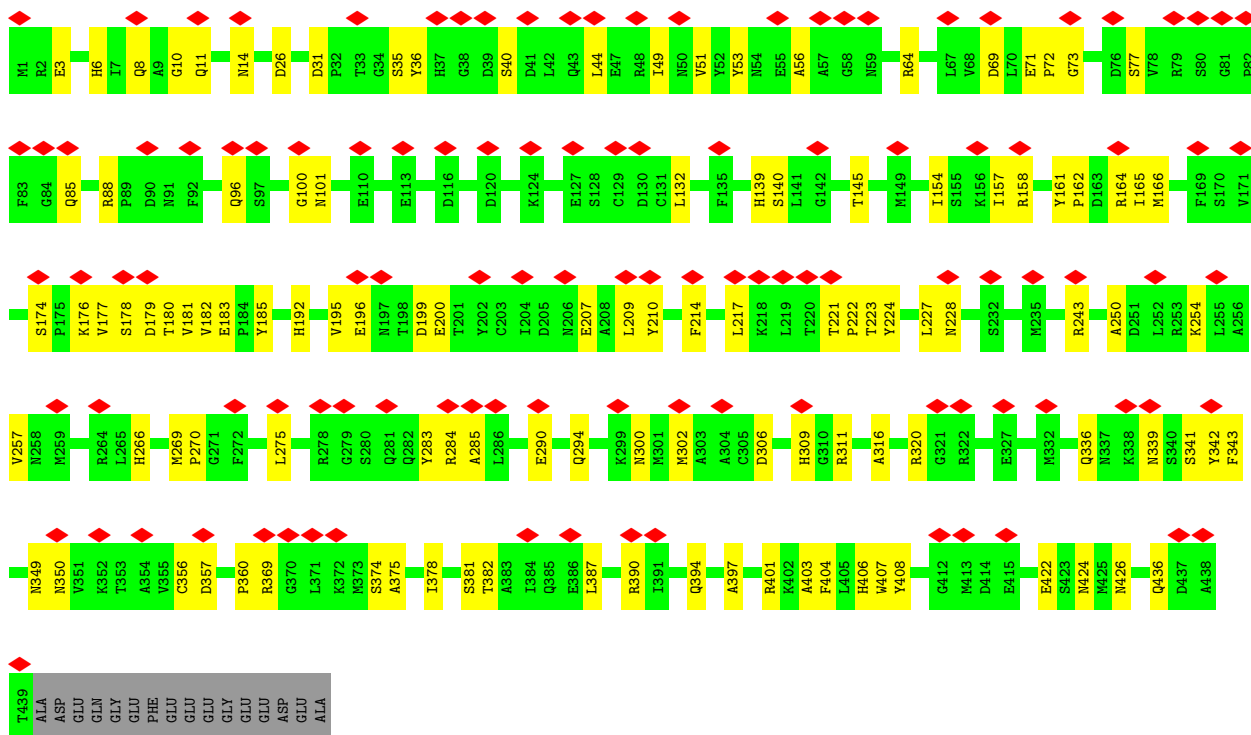

• Molecule 2: Tubulin beta chain

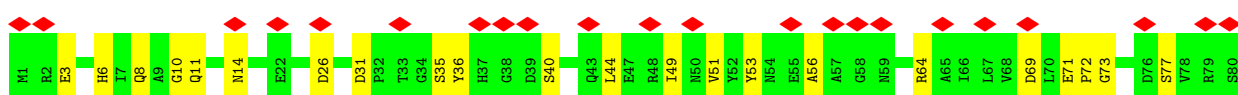

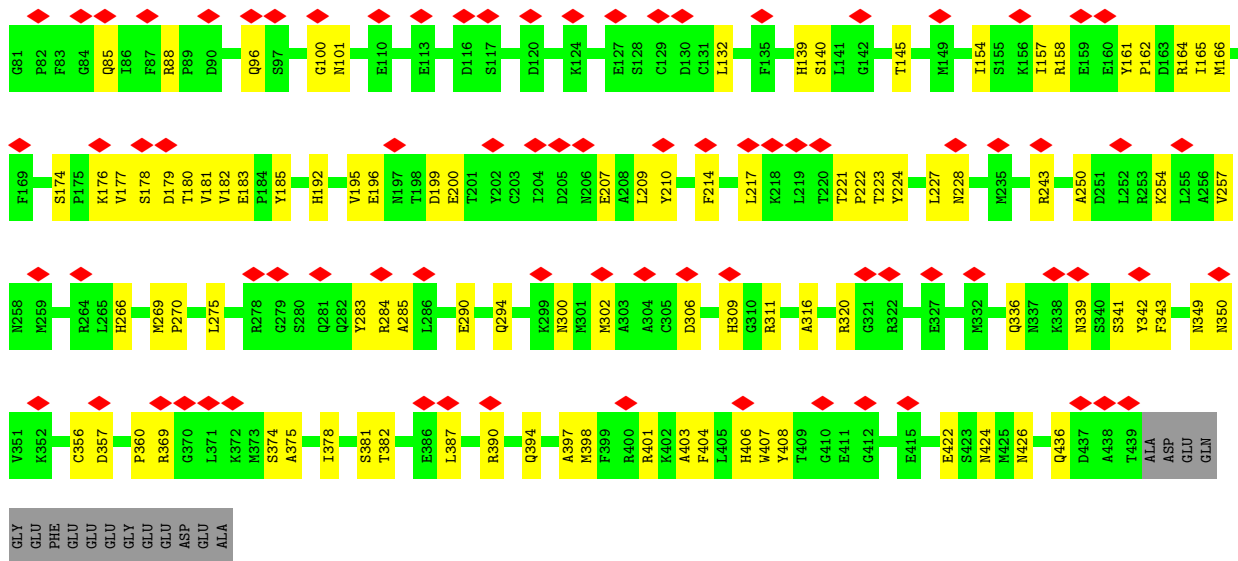

• Molecule 2: Tubulin beta chain



• Molecule 2: Tubulin beta chain



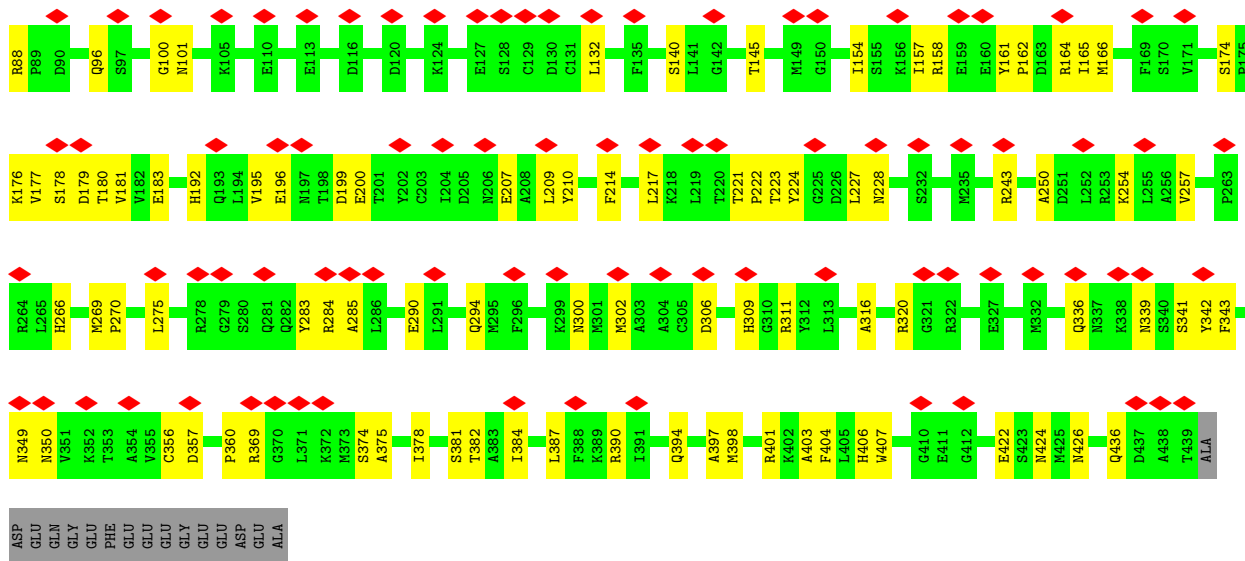

• Molecule 2: Tubulin beta chain

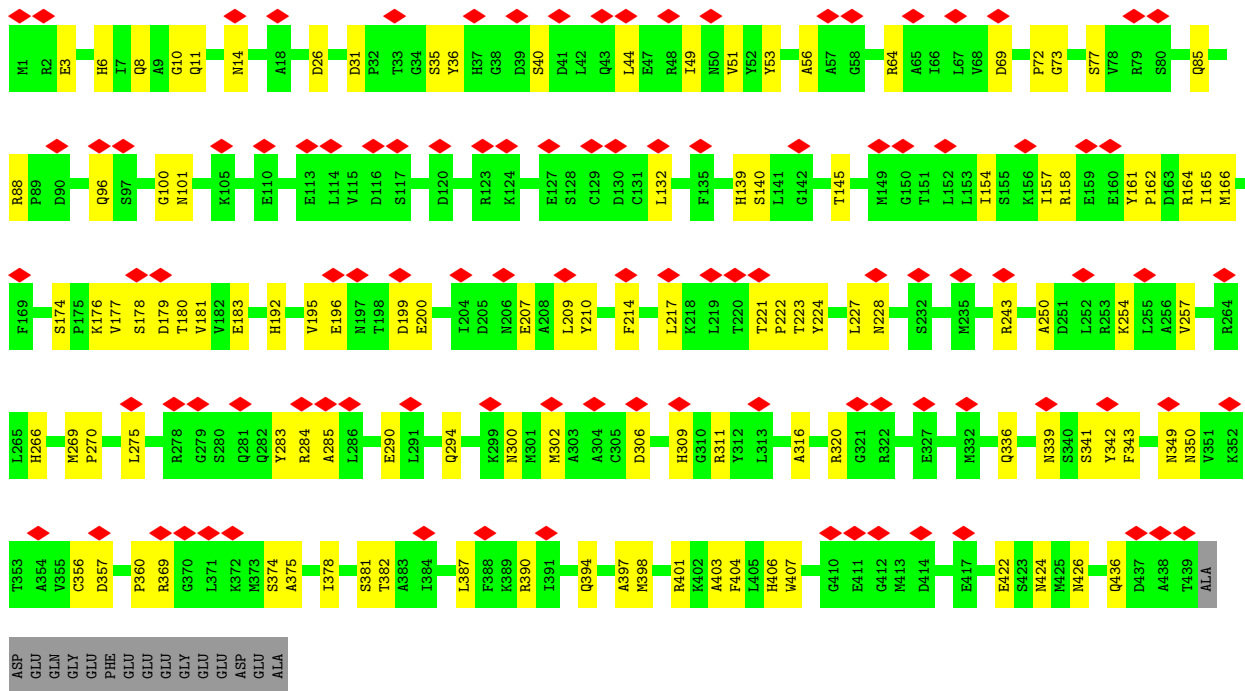

• Molecule 2: Tubulin beta chain

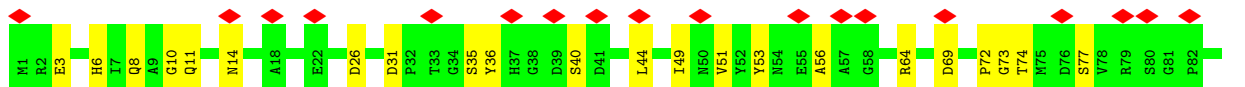
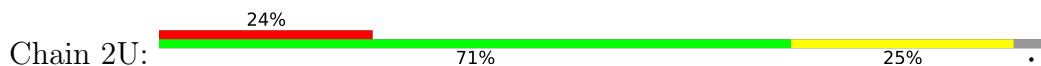

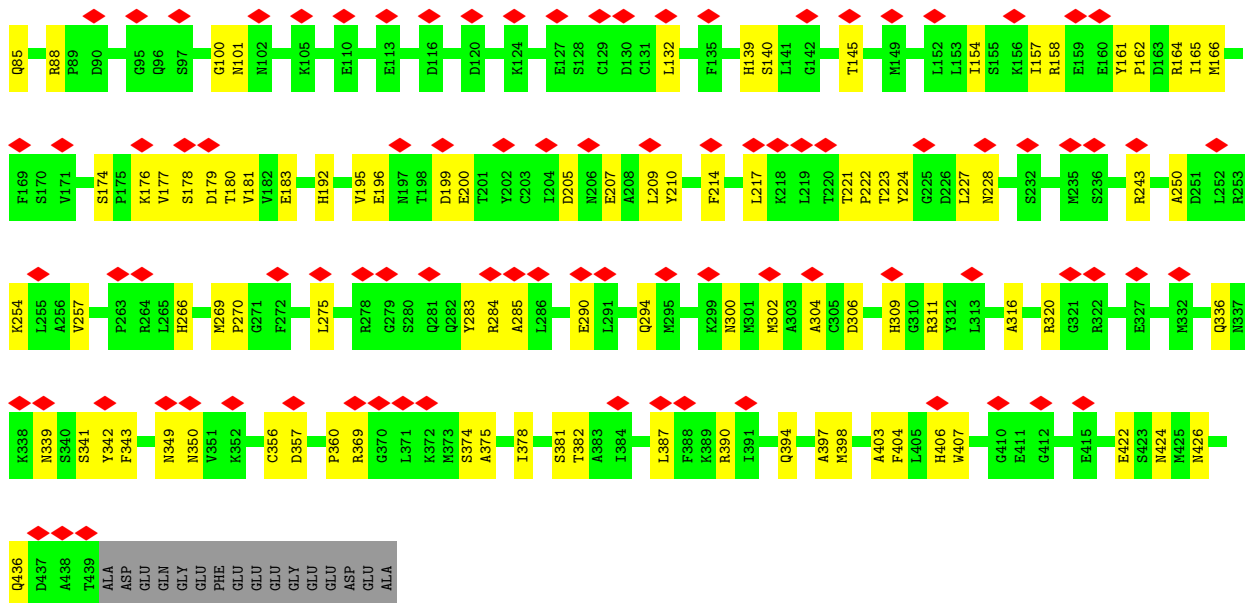

• Molecule 2: Tubulin beta chain

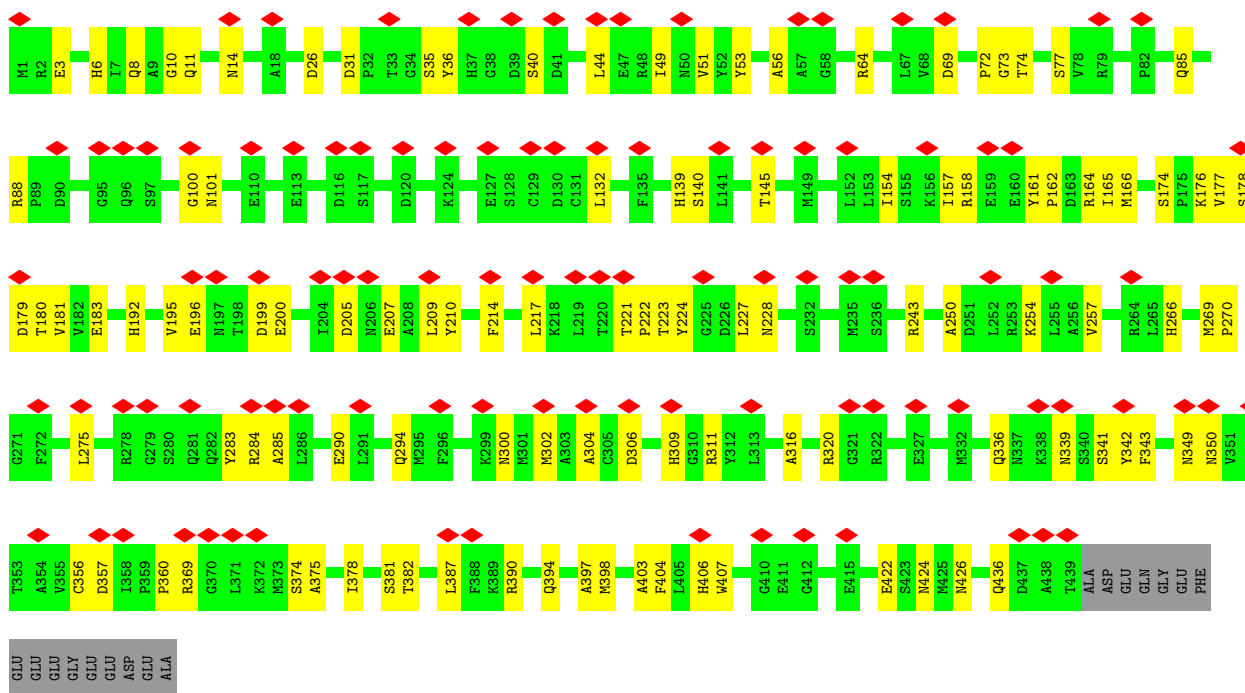
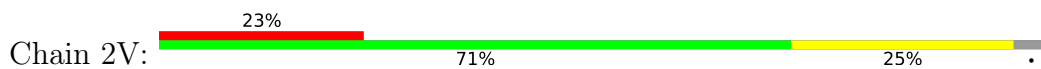

• Molecule 2: Tubulin beta chain

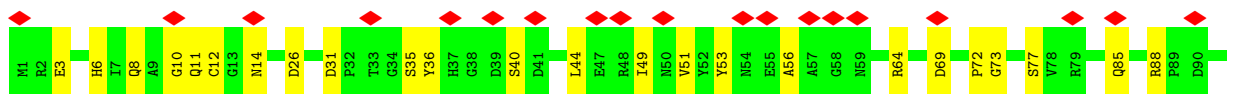
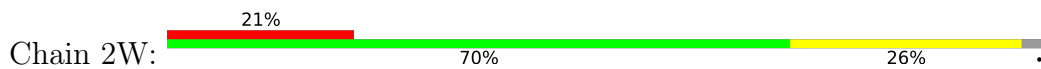

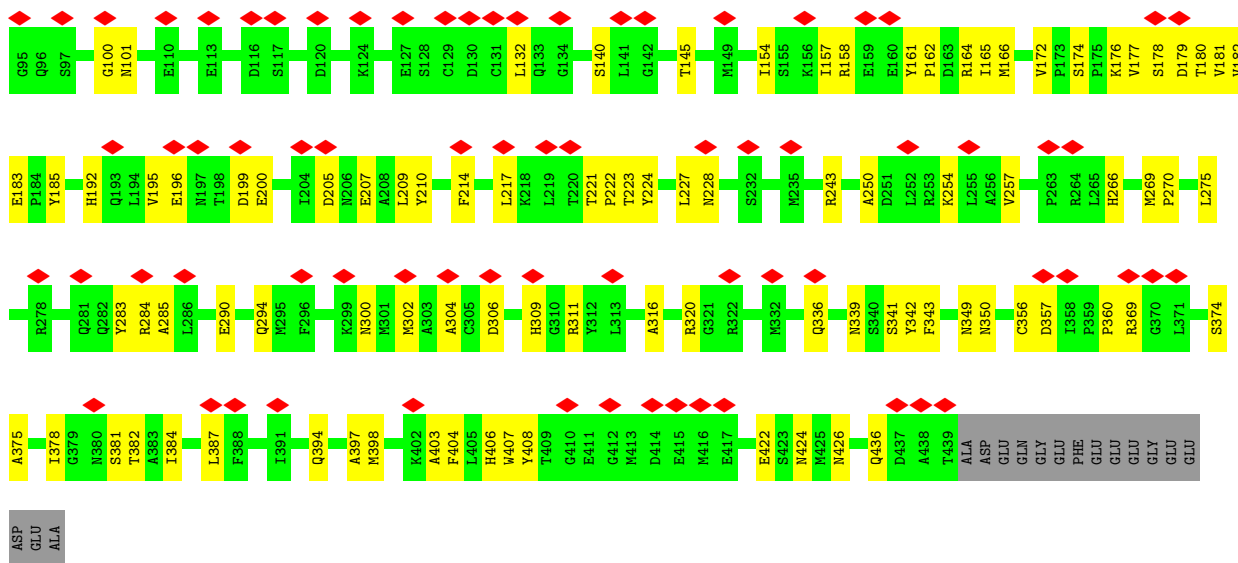

• Molecule 2: Tubulin beta chain

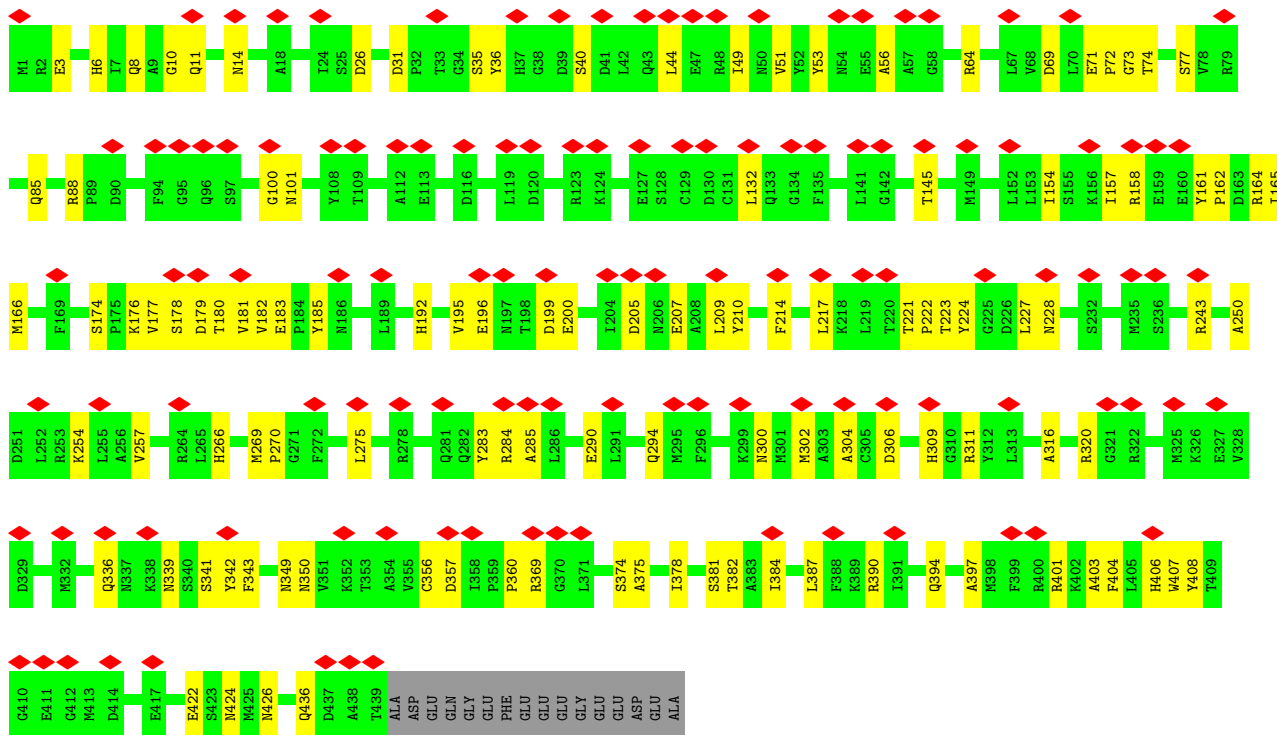

• Molecule 2: Tubulin beta chain

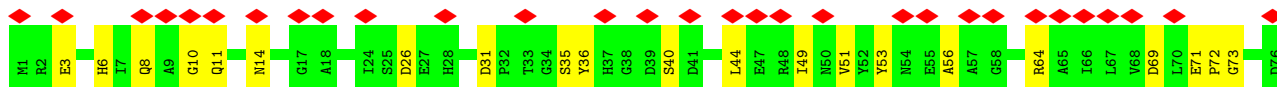
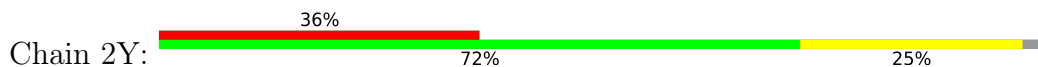

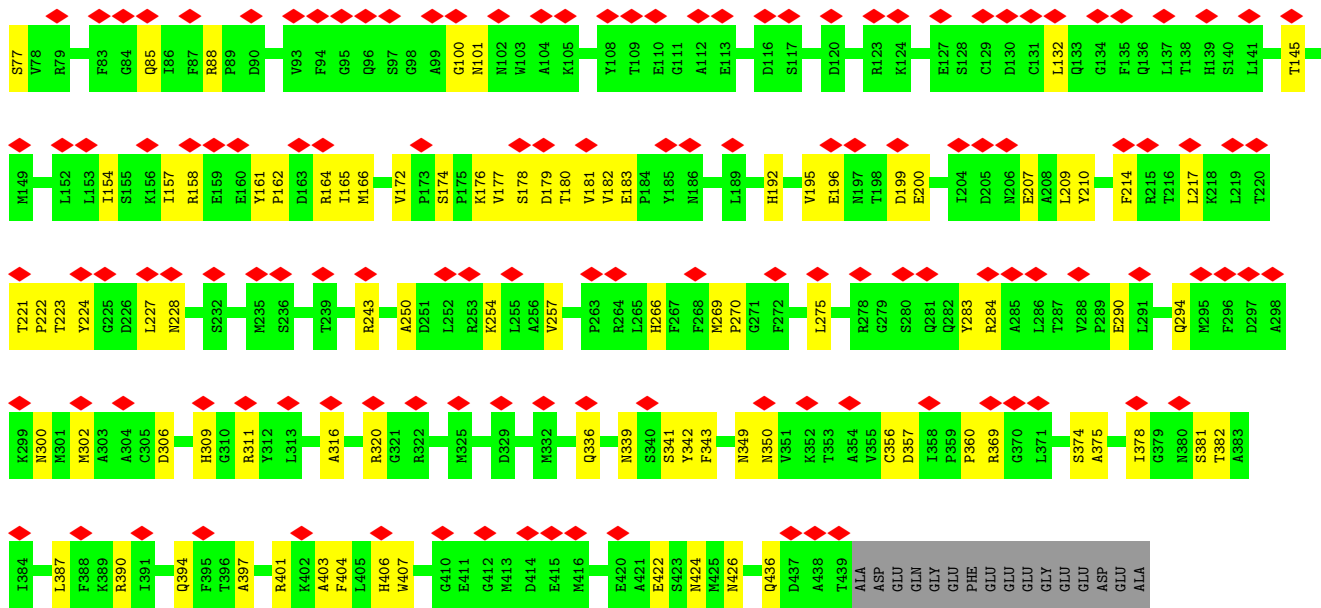

• Molecule 2: Tubulin beta chain

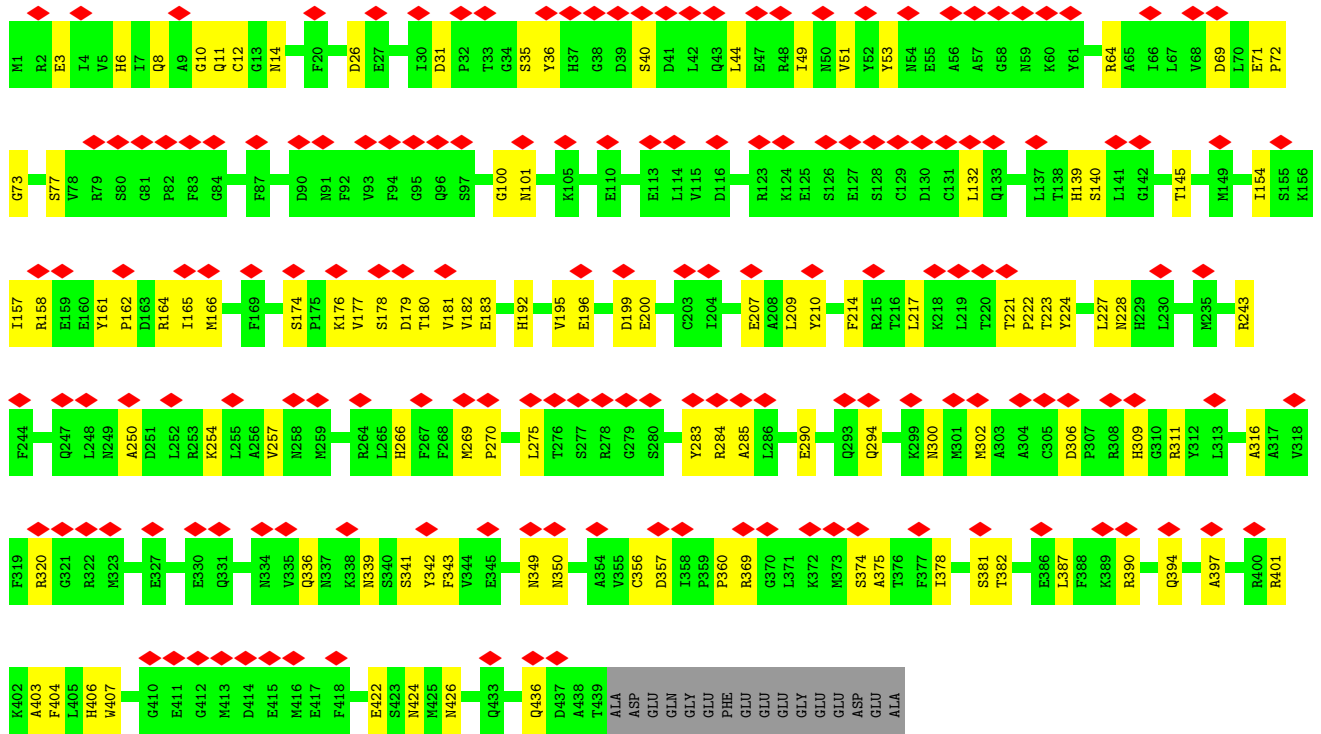
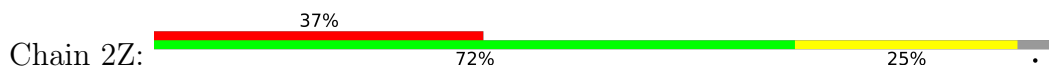

• Molecule 2: Tubulin beta chain

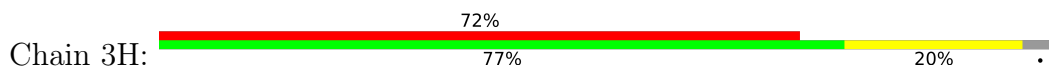

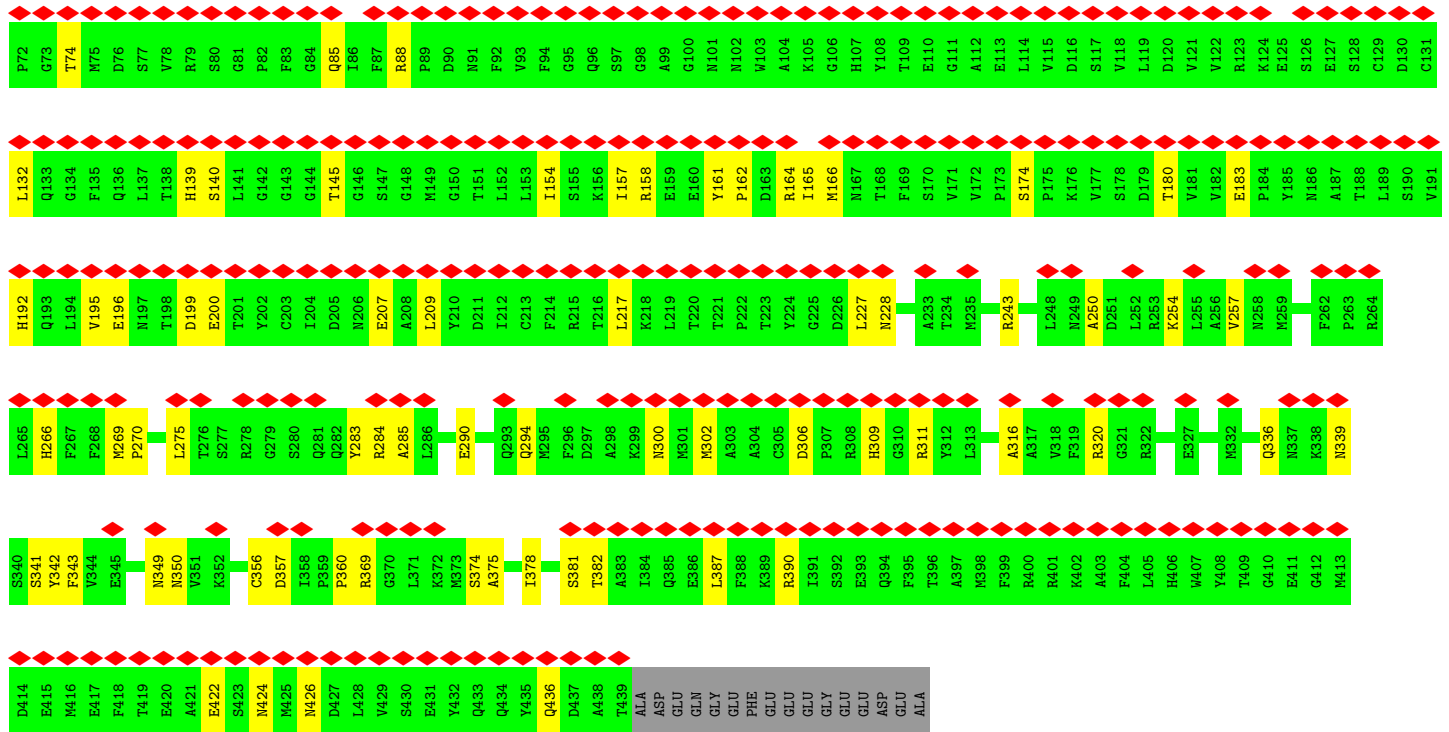

• Molecule 2: Tubulin beta chain

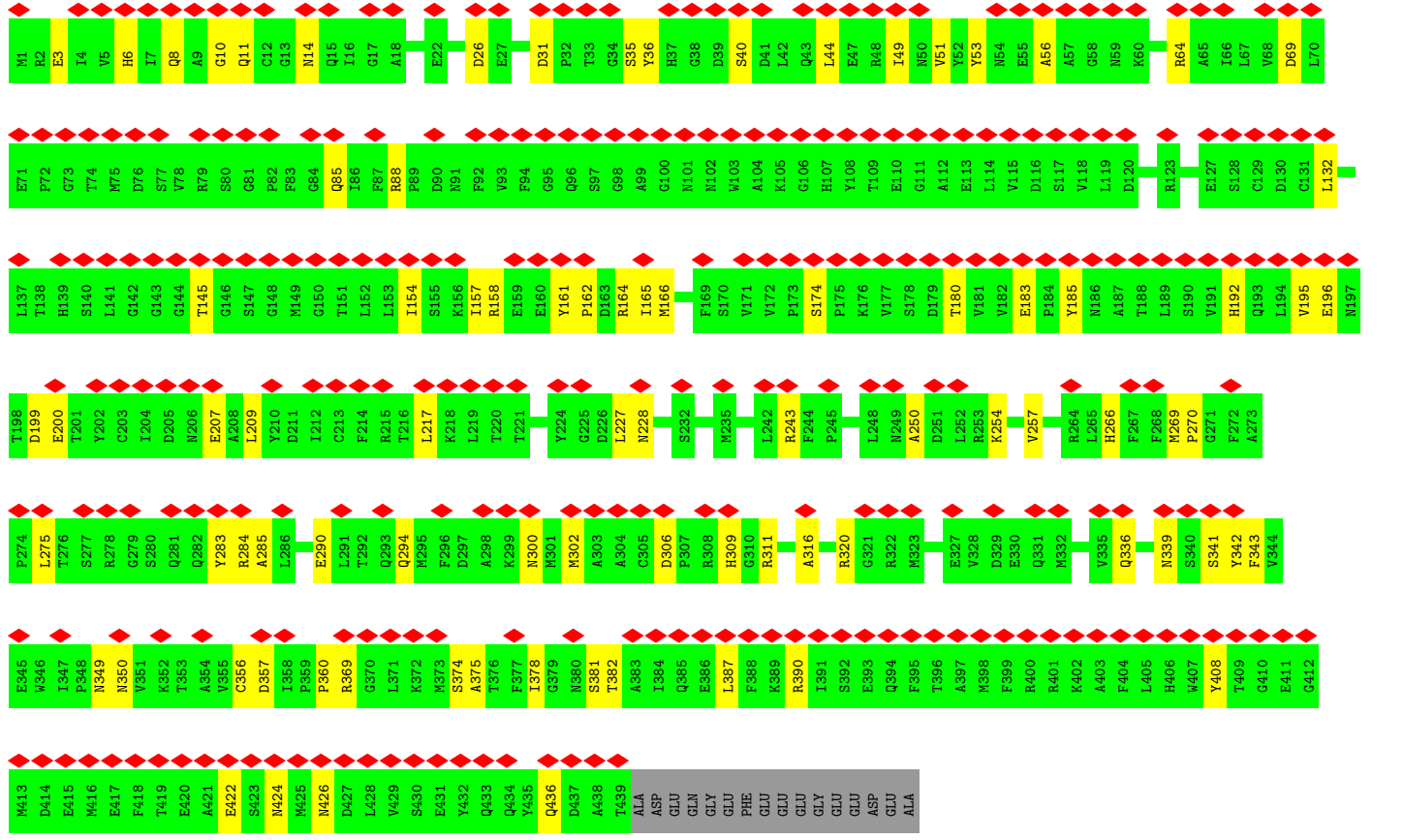
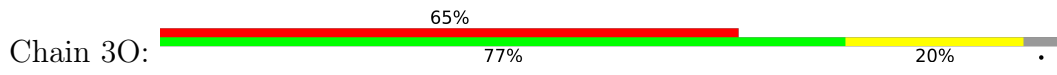

• Molecule 2: Tubulin beta chain

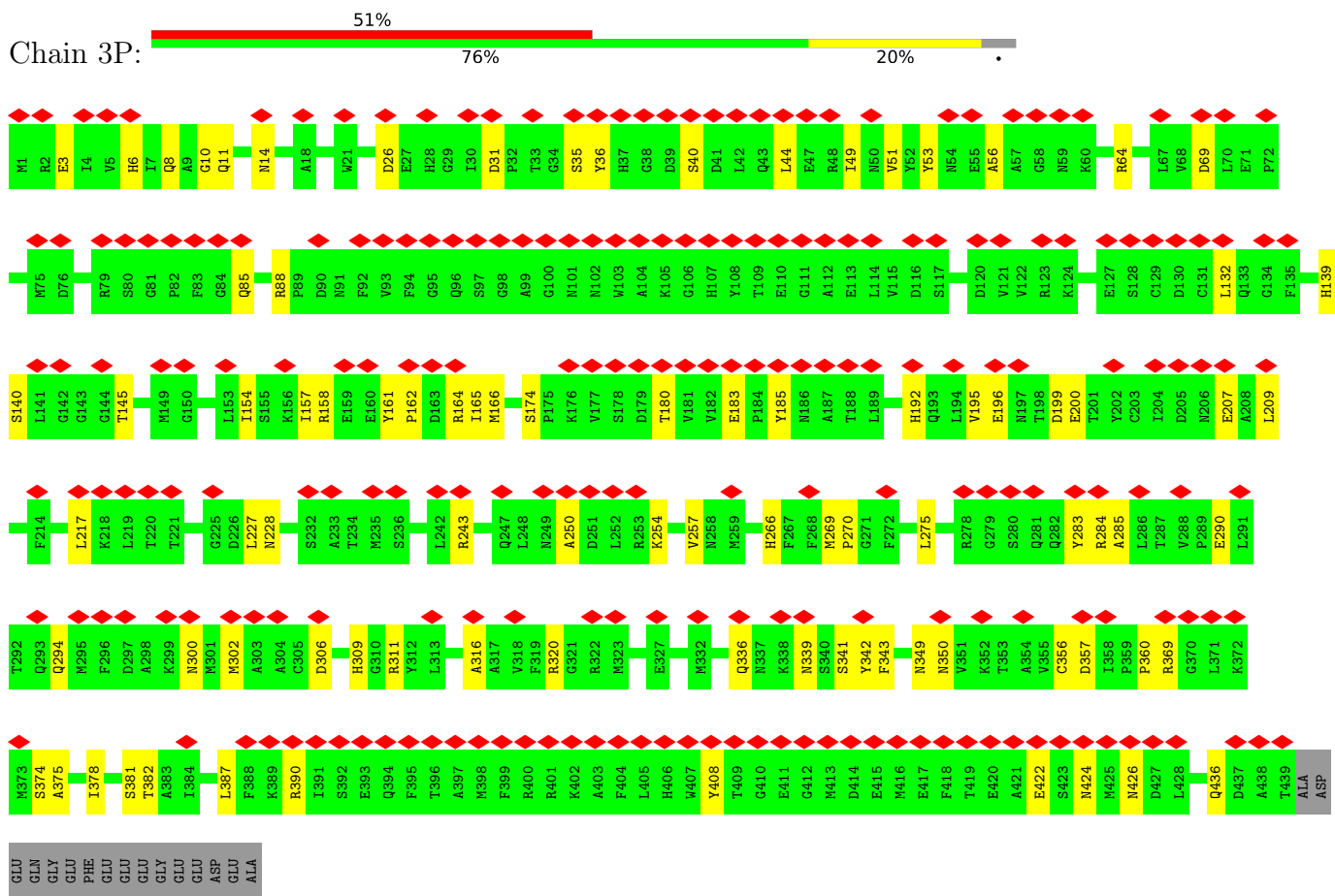

• Molecule 2: Tubulin beta chain

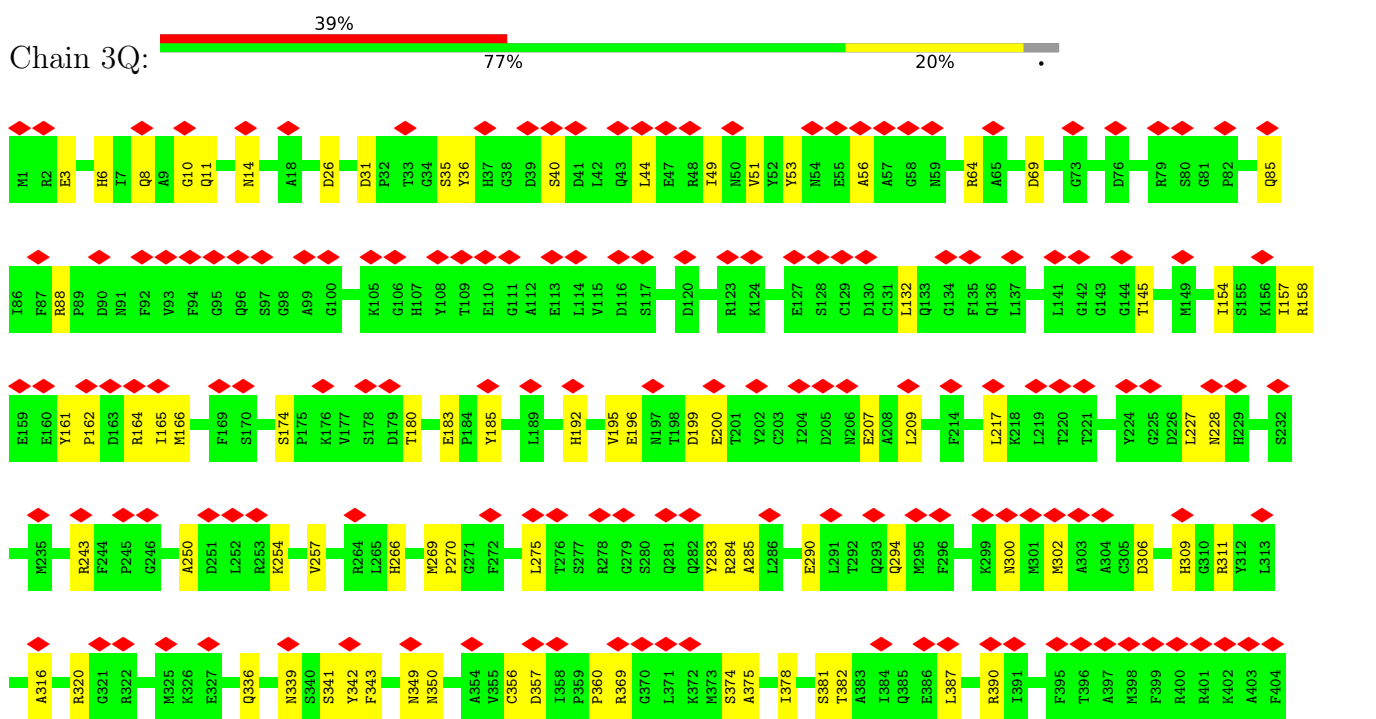



• Molecule 2: Tubulin beta chain

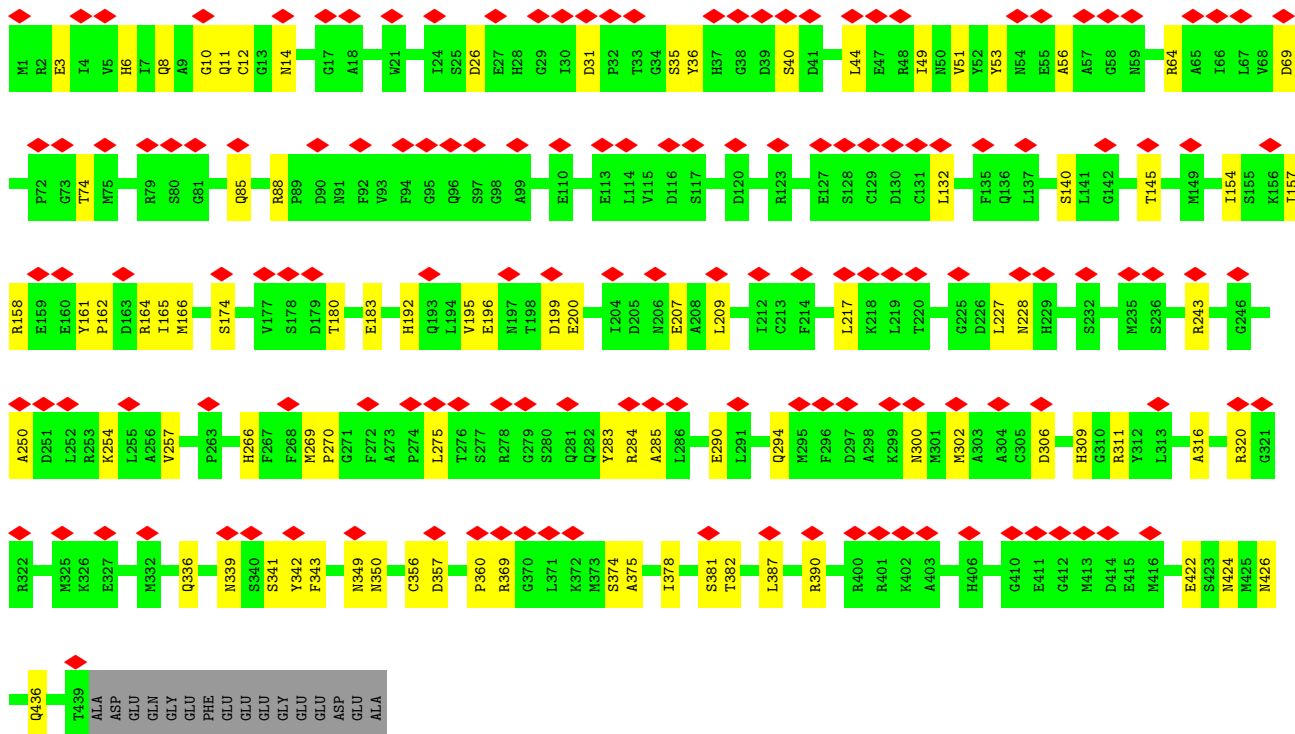
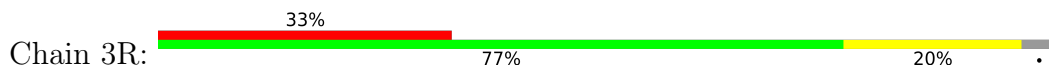

• Molecule 2: Tubulin beta chain

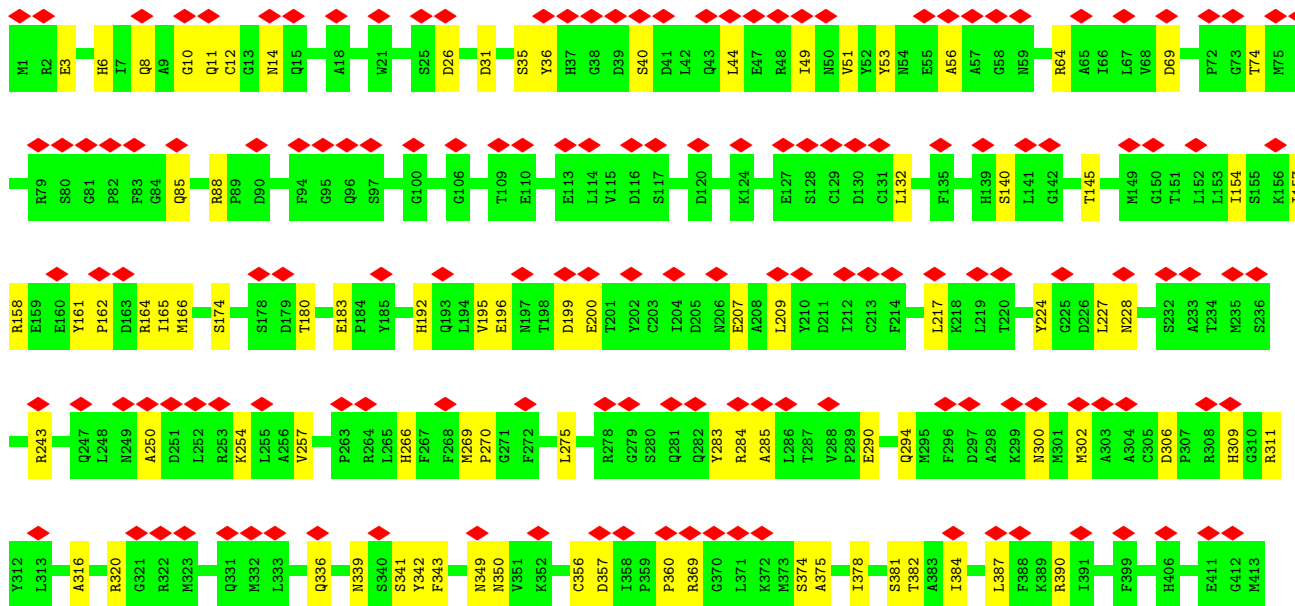
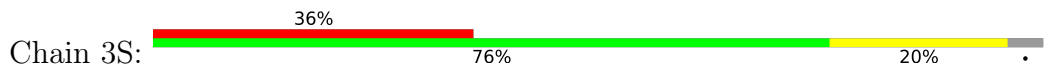

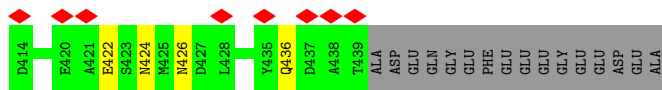

• Molecule 2: Tubulin beta chain

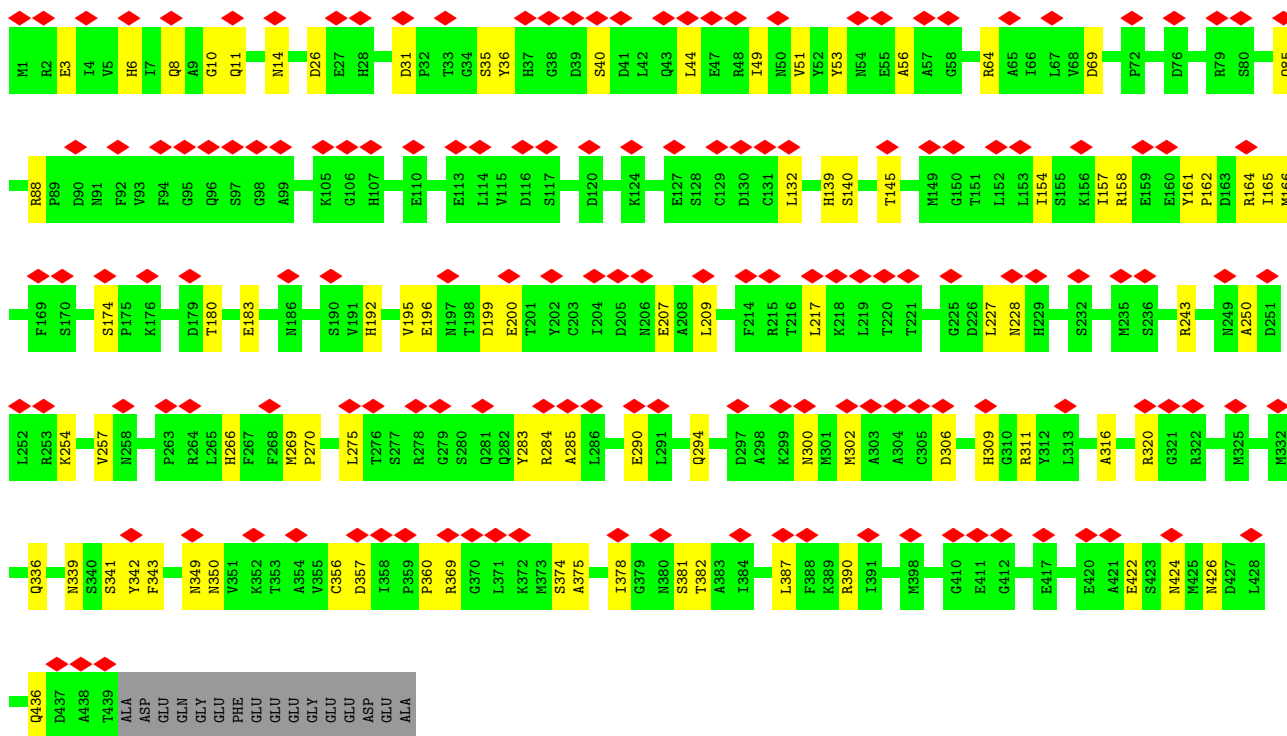
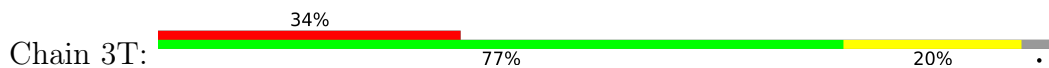

• Molecule 2: Tubulin beta chain

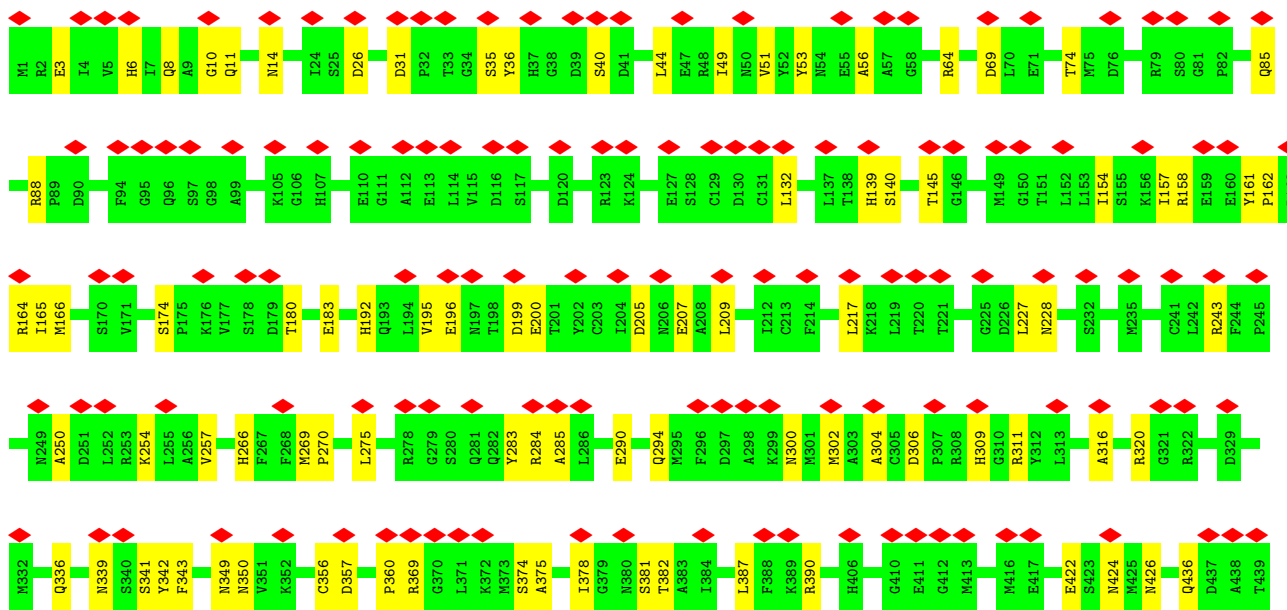
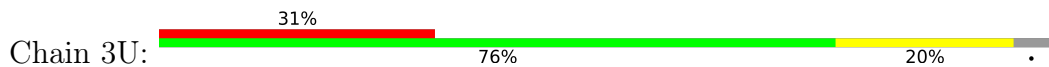

ALA
ASP
GLU
GLN
GLY
GLY
PHE
GLU
GLU
GLY
GLY
GLU
GLU
ASP
GLU
ALA

• Molecule 2: Tubulin beta chain

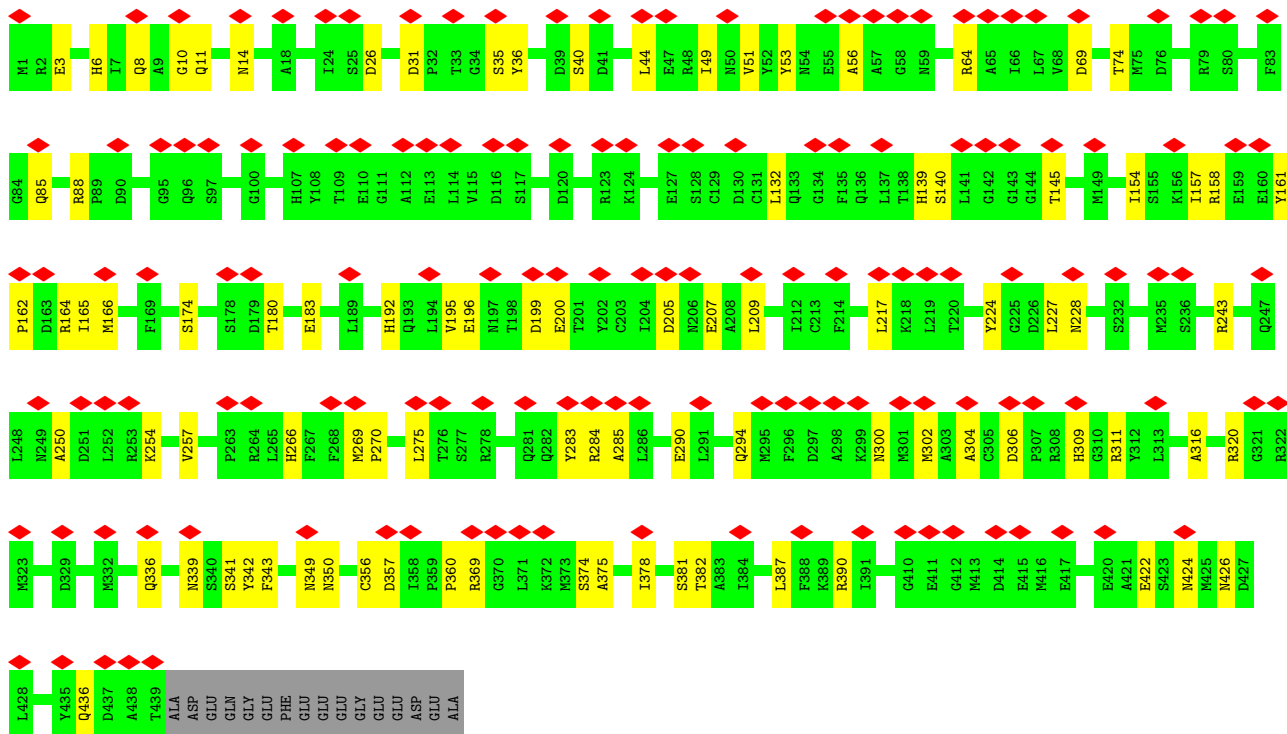
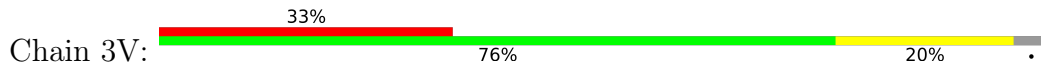

• Molecule 2: Tubulin beta chain

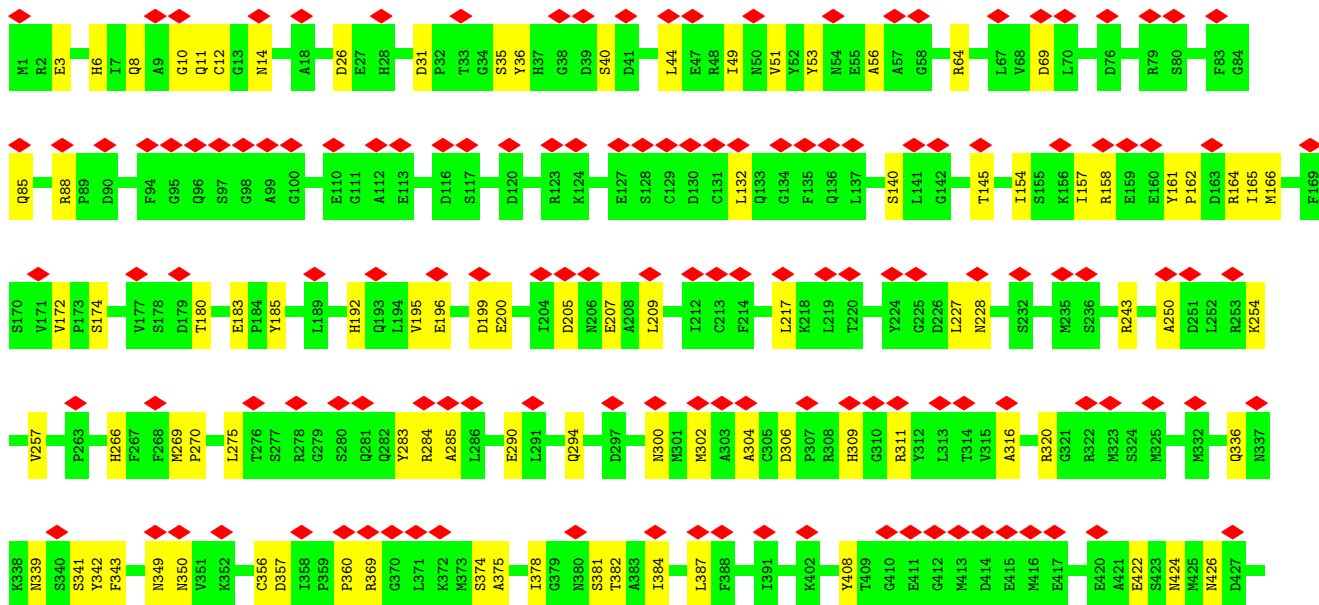
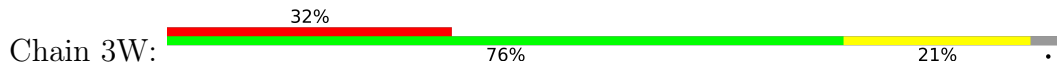

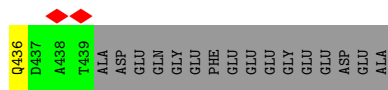

• Molecule 2: Tubulin beta chain

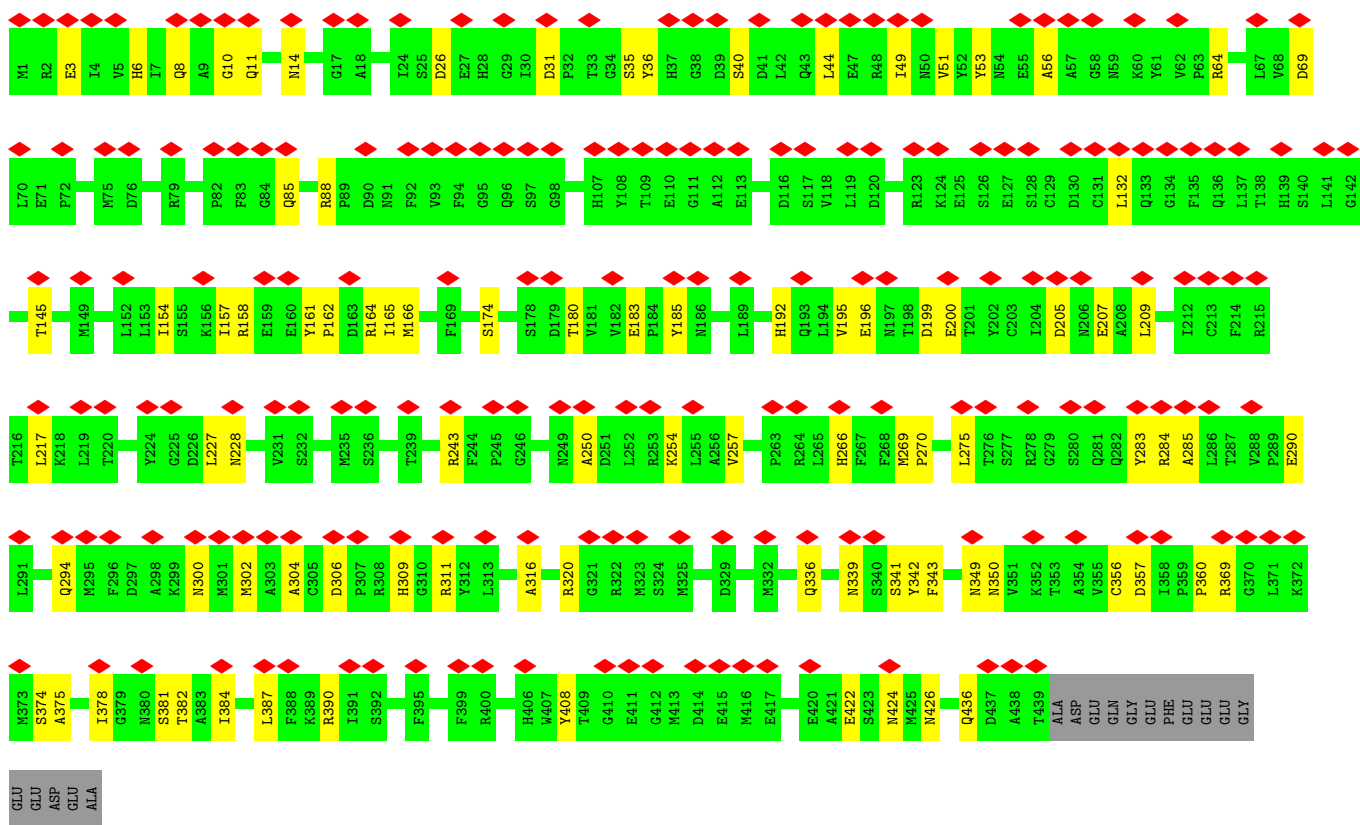
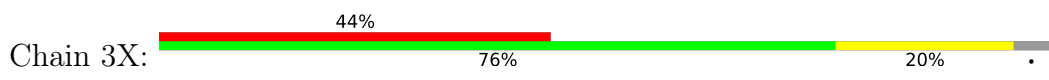

• Molecule 2: Tubulin beta chain

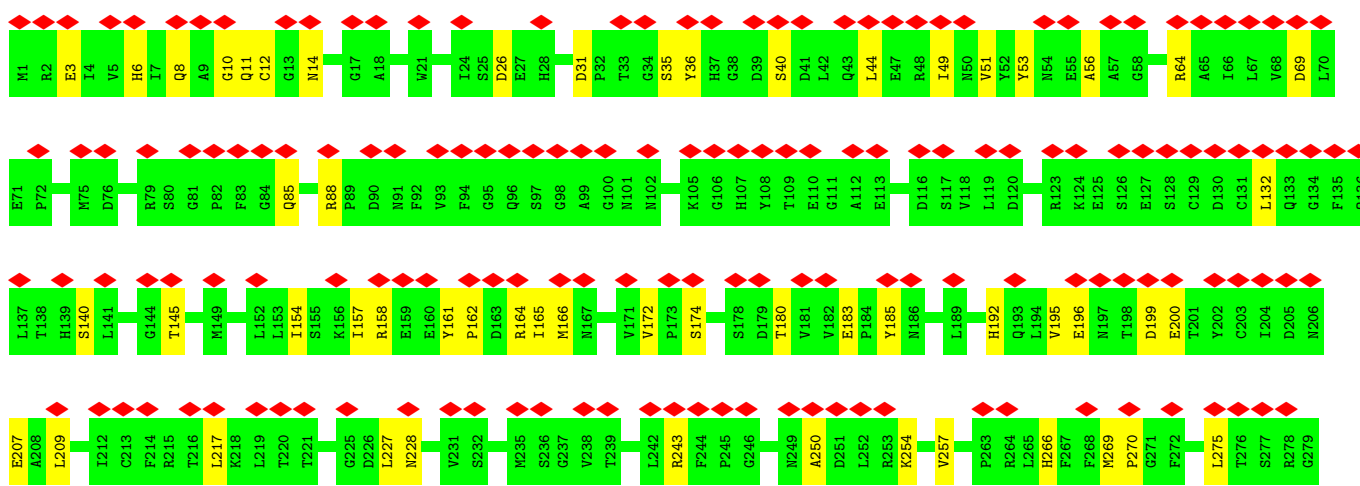
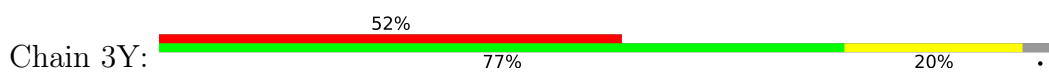

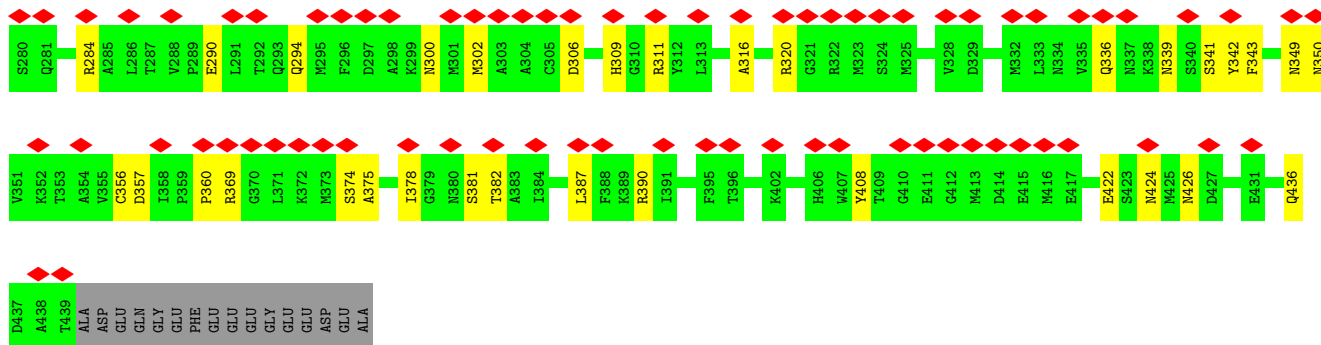

• Molecule 2: Tubulin beta chain

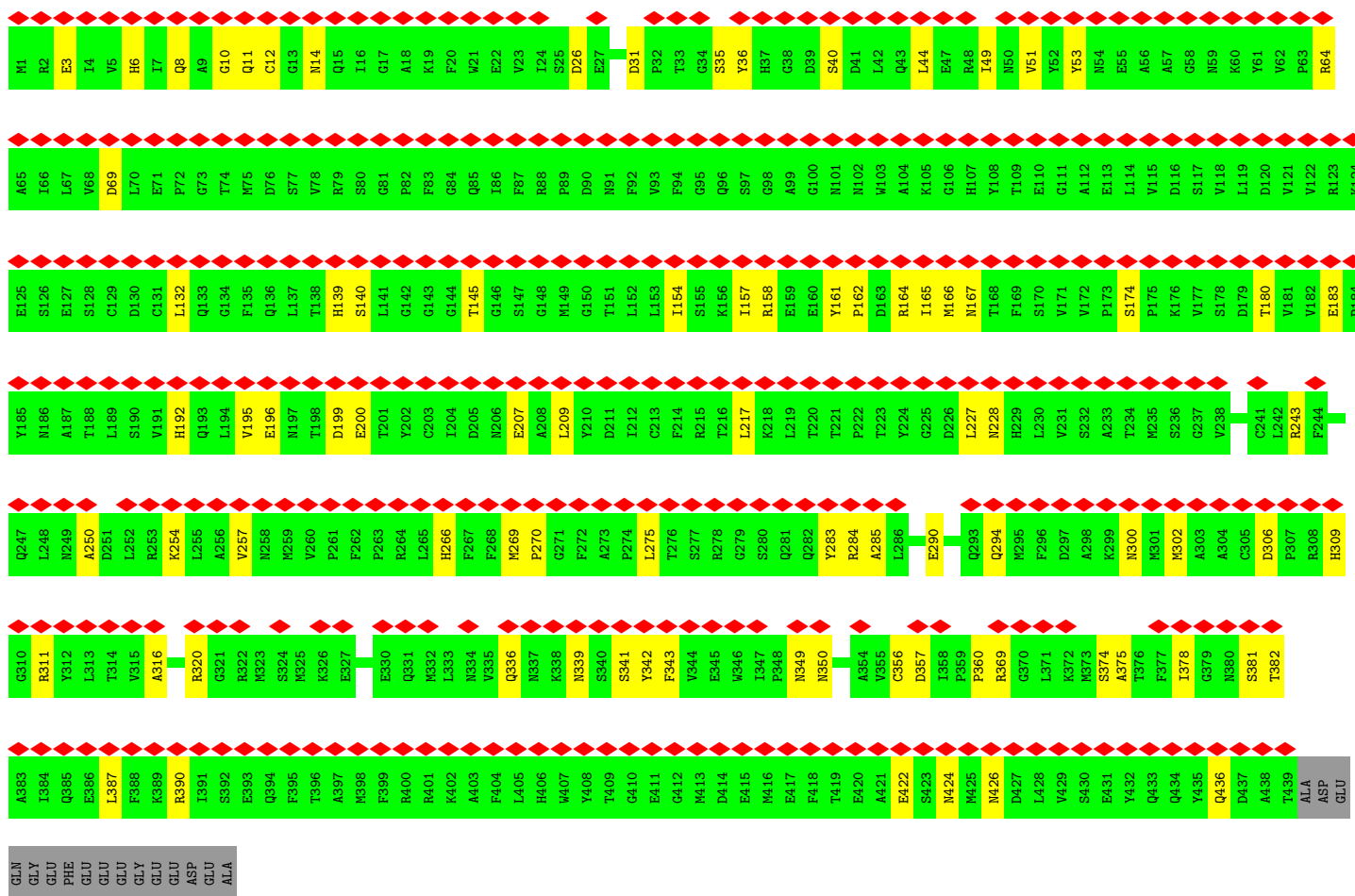
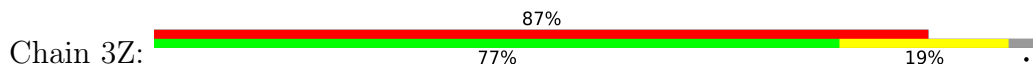

• Molecule 2: Tubulin beta chain



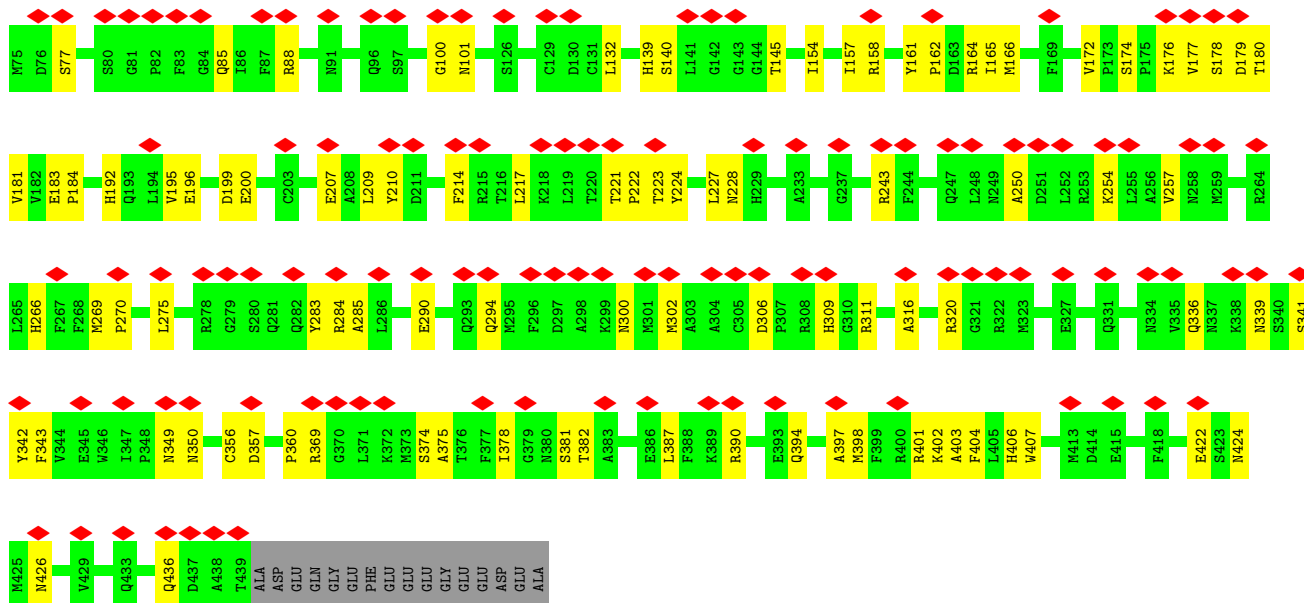

• Molecule 2: Tubulin beta chain

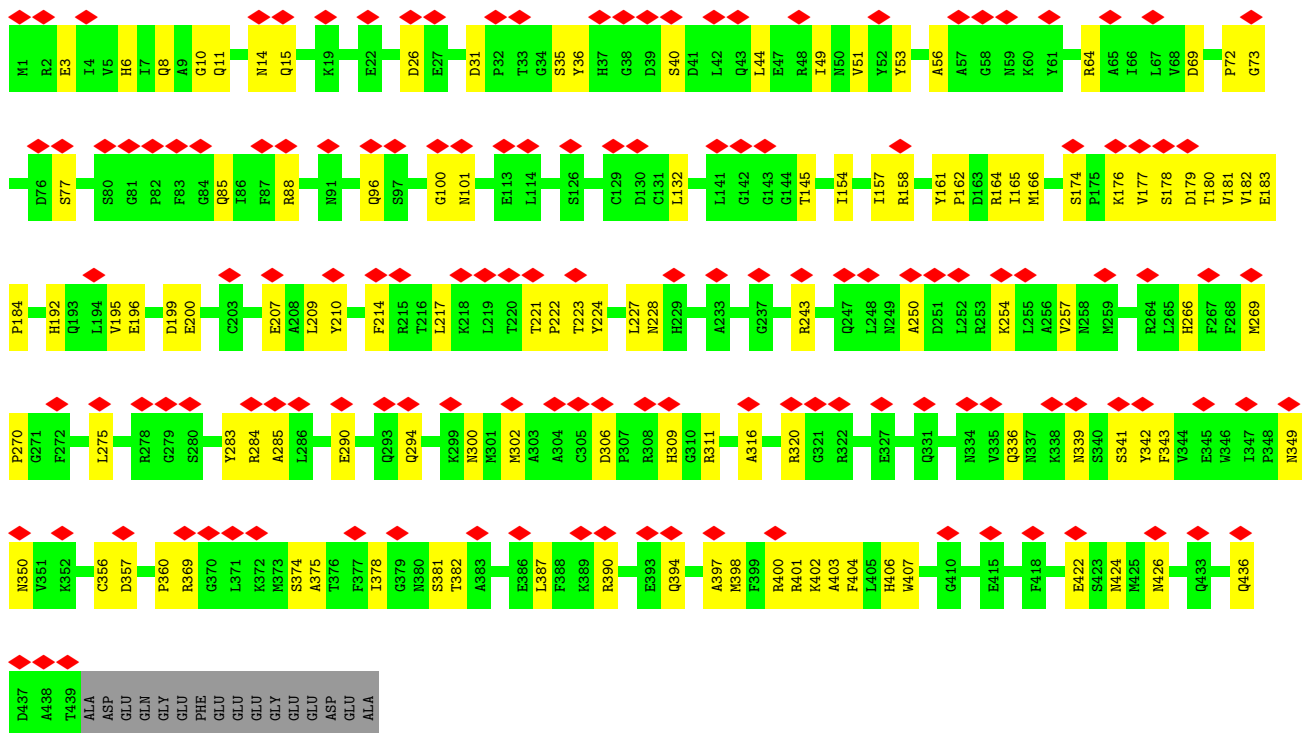
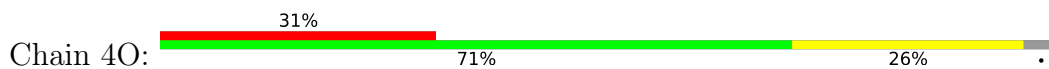

• Molecule 2: Tubulin beta chain

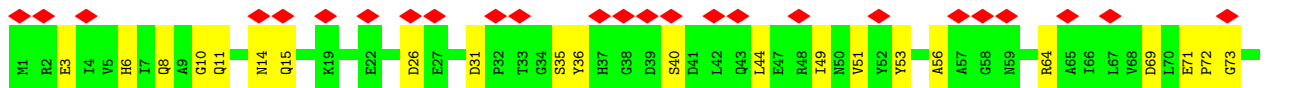

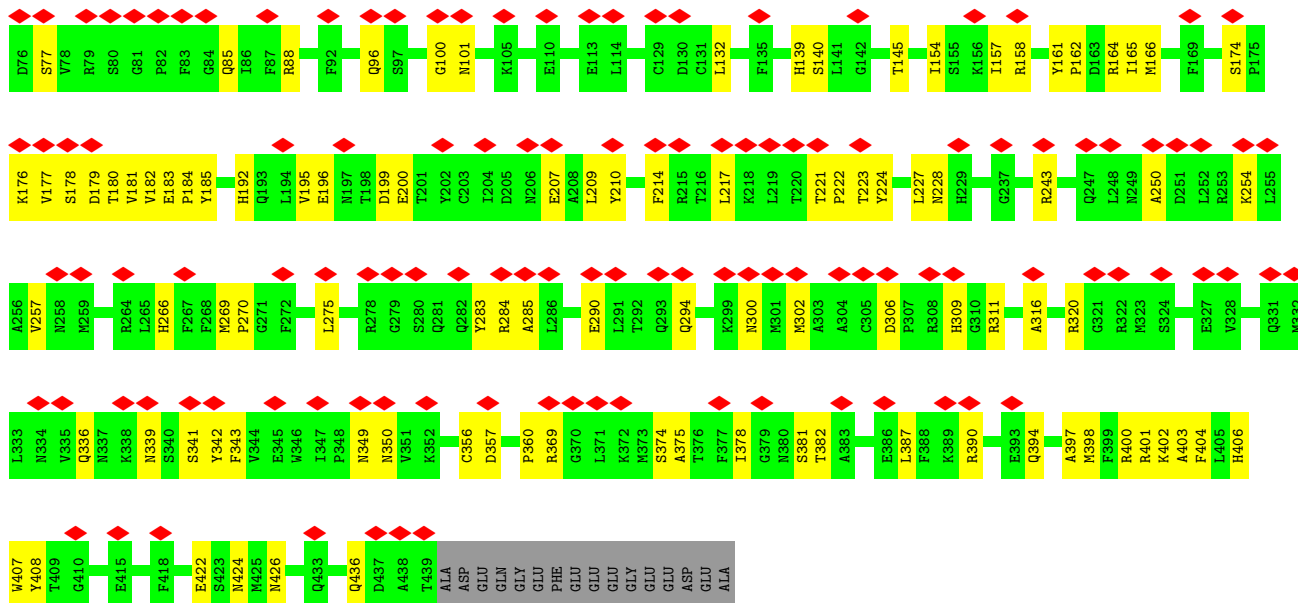

• Molecule 2: Tubulin beta chain

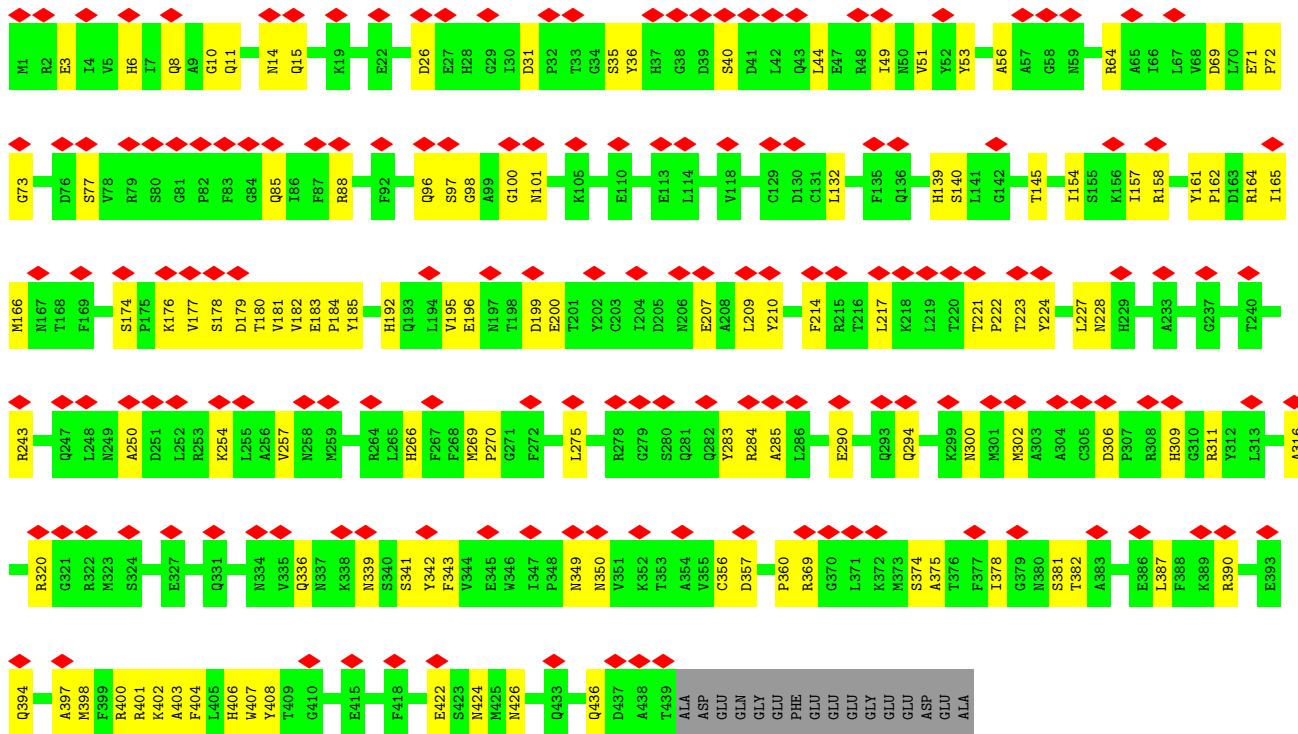

• Molecule 2: Tubulin beta chain



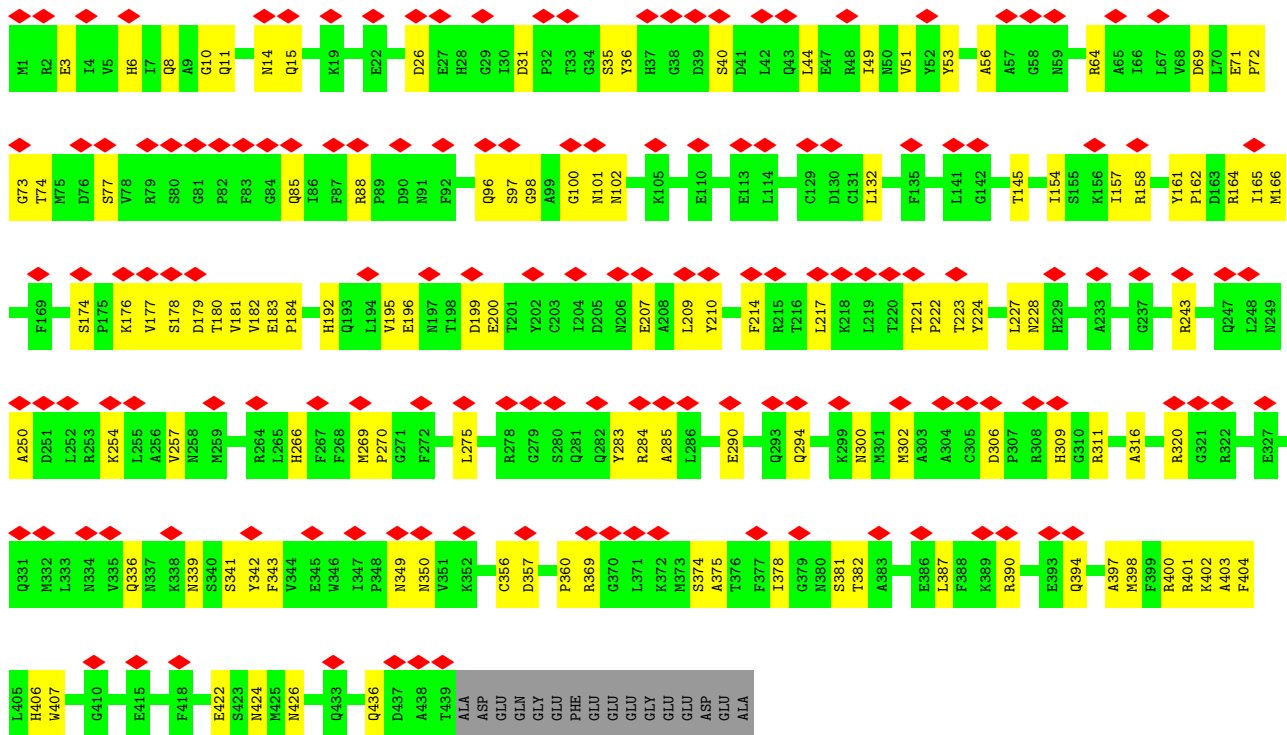

• Molecule 2: Tubulin beta chain

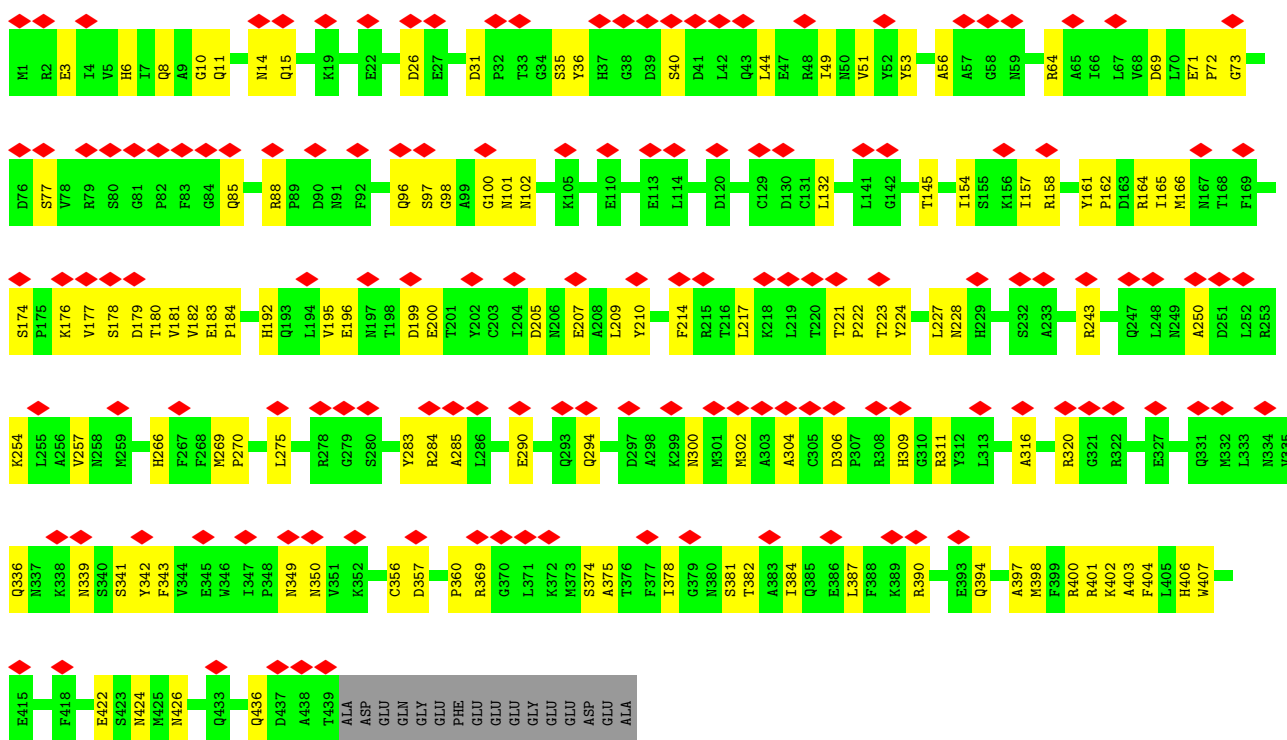

• Molecule 2: Tubulin beta chain



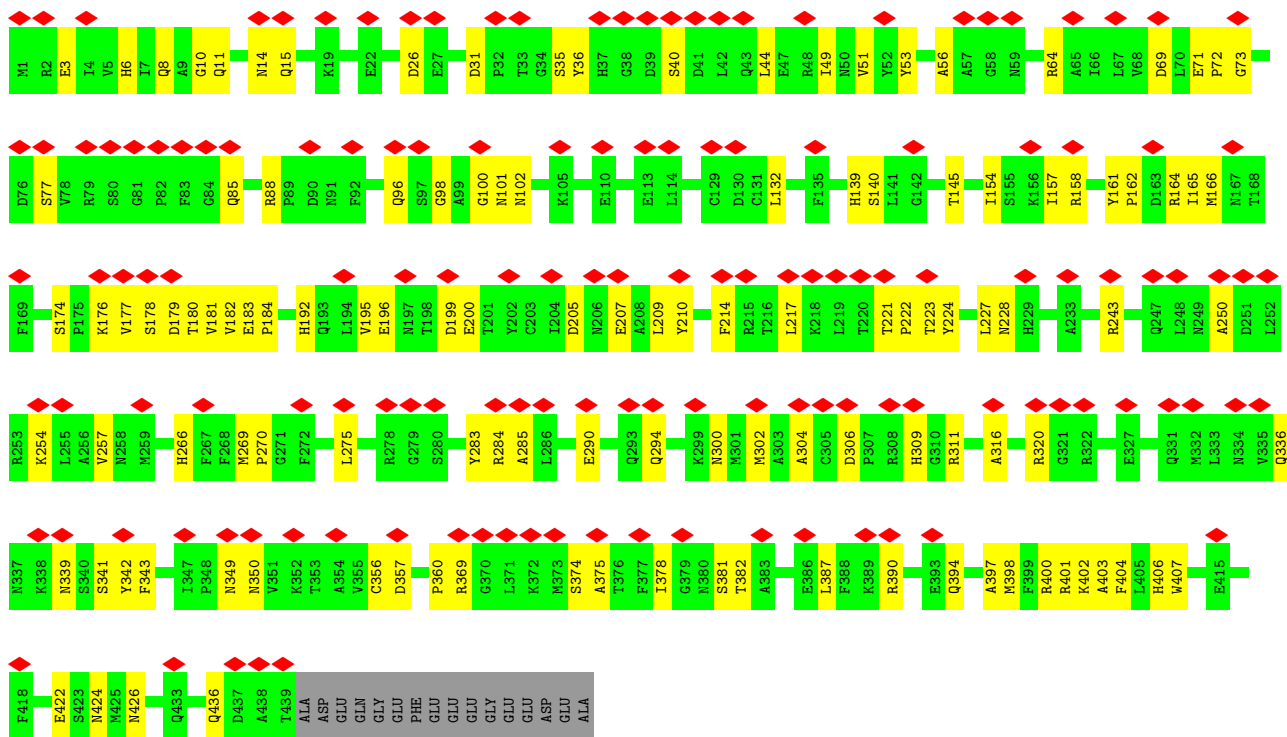

• Molecule 2: Tubulin beta chain

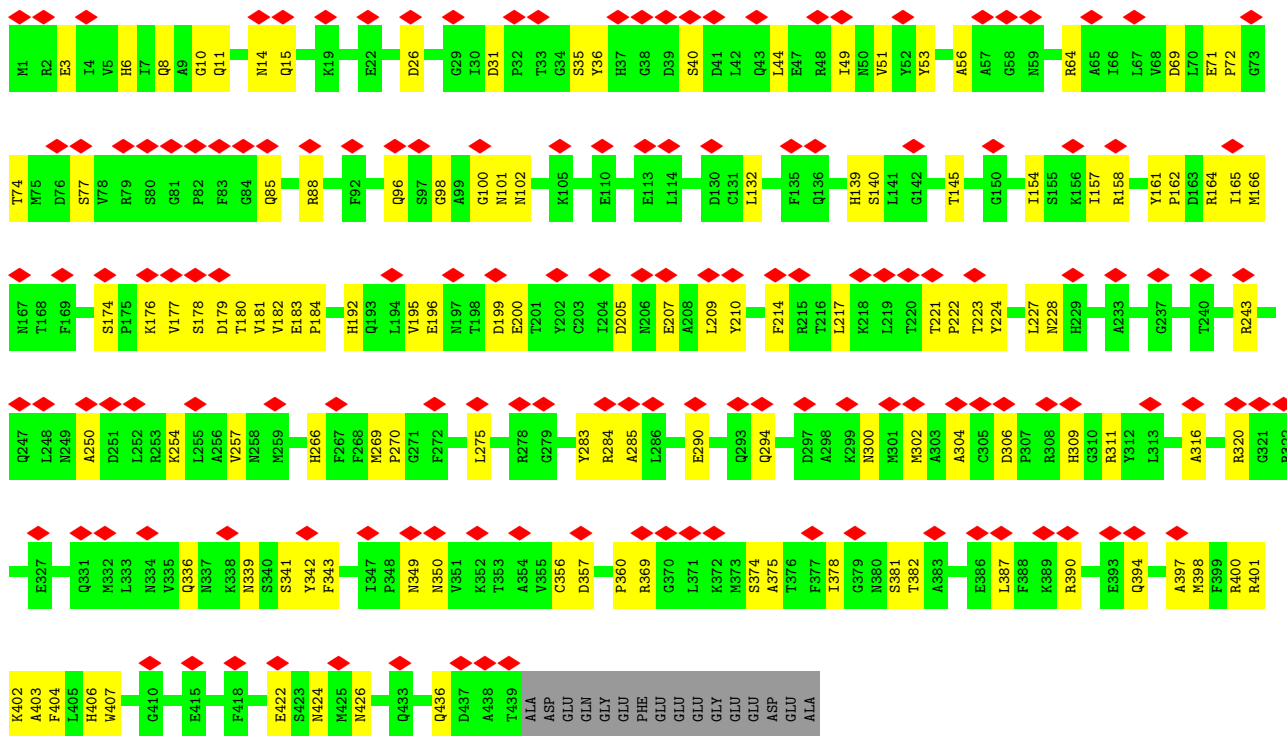

• Molecule 2: Tubulin beta chain



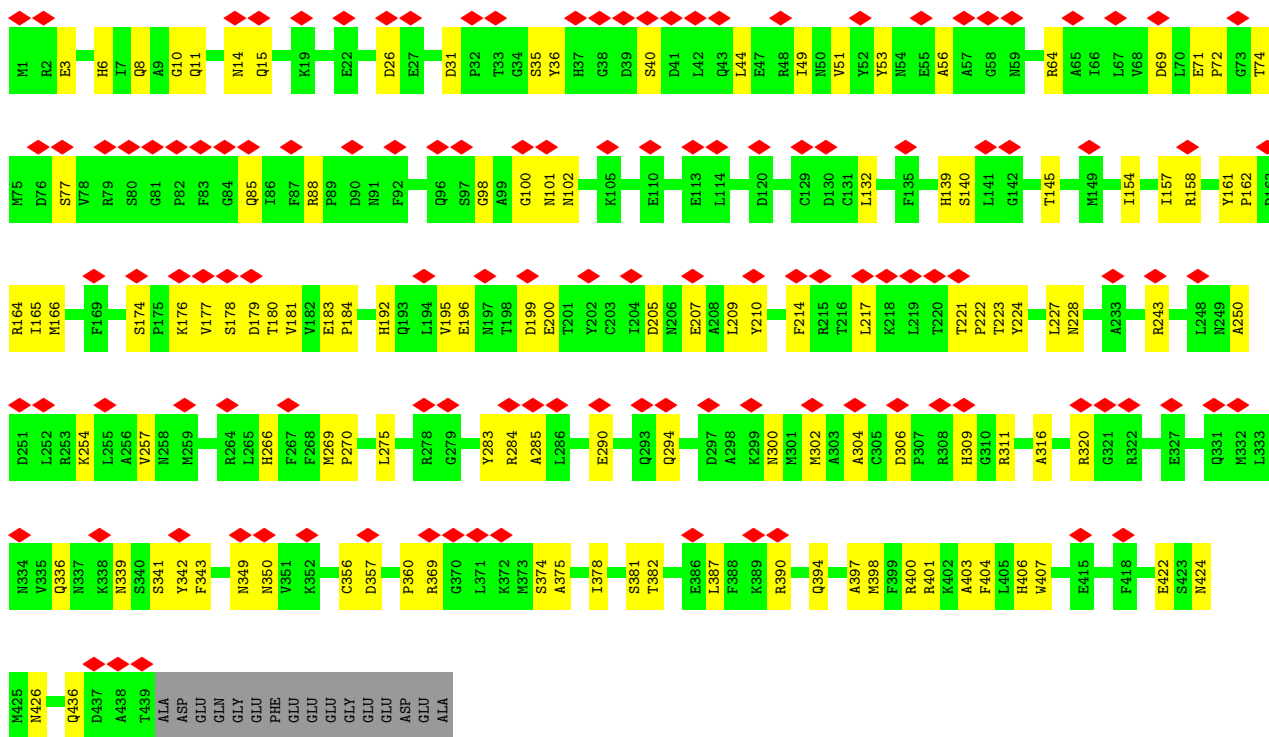

• Molecule 2: Tubulin beta chain

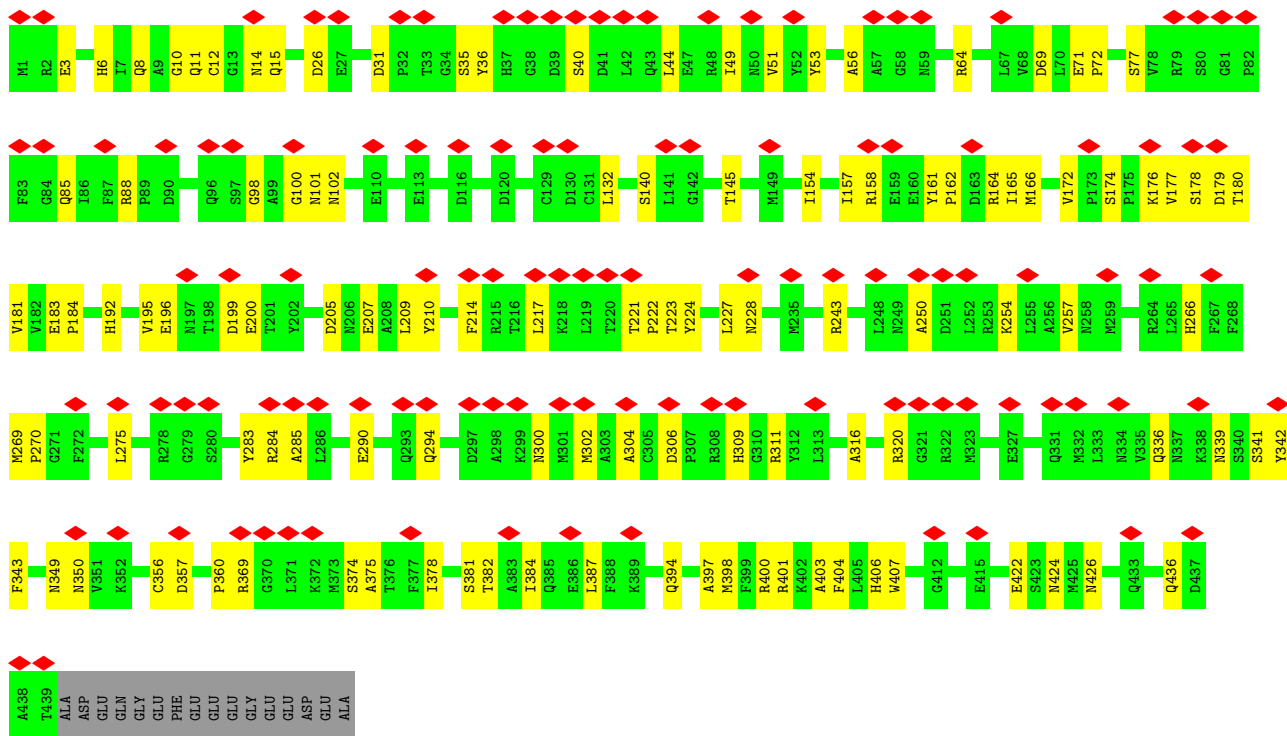

• Molecule 2: Tubulin beta chain

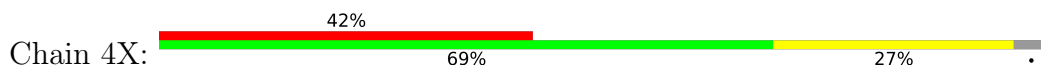

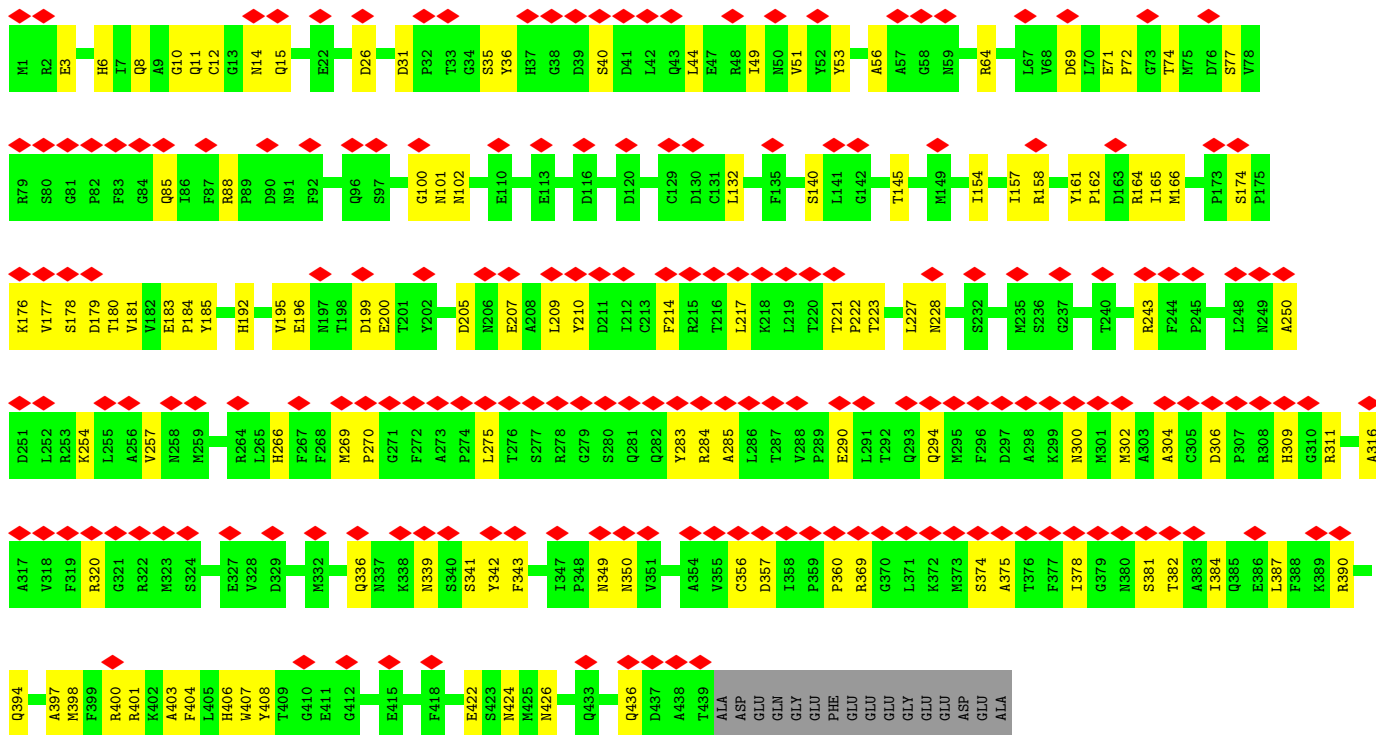

• Molecule 2: Tubulin beta chain

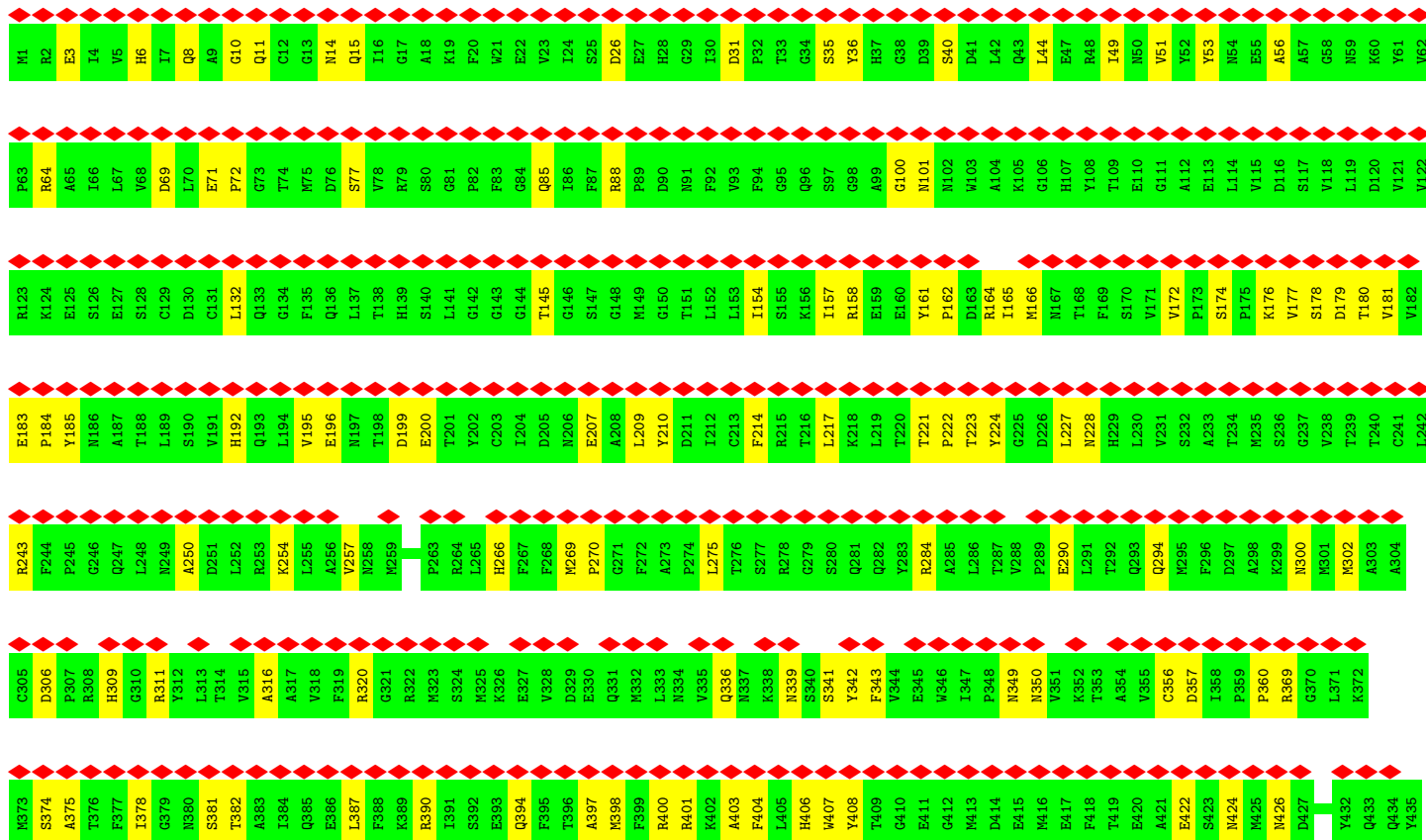
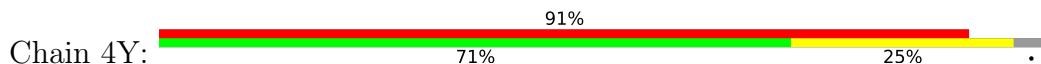

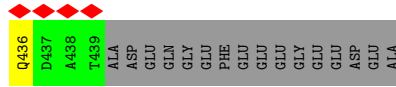

• Molecule 2: Tubulin beta chain

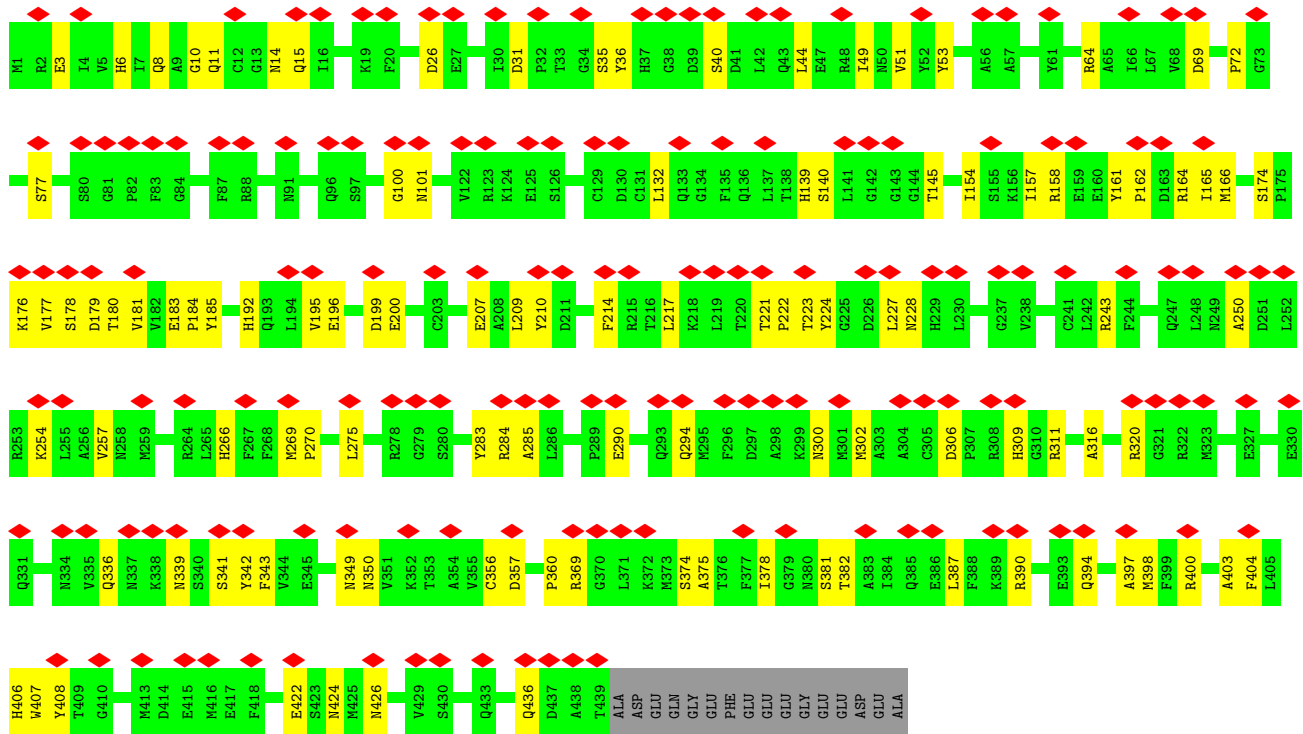
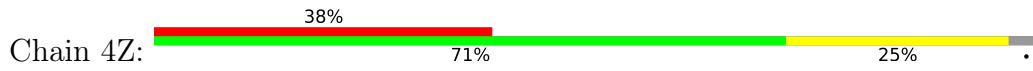

4 Experimental information

Property	Value	Source
EM reconstruction method	HELICAL	Depositor
Imposed symmetry	HELICAL, twist=-27.7°, rise=9.3 Å, axial sym=C1	Depositor
Number of segments used	24692	Depositor
Resolution determination method	FSC 0.143 CUT-OFF	Depositor
CTF correction method	PHASE FLIPPING AND AMPLITUDE CORRECTION; CTFFIND4	Depositor
Microscope	FEI TITAN KRIOS	Depositor
Voltage (kV)	300	Depositor
Electron dose ($e^-/\text{Å}^2$)	25	Depositor
Minimum defocus (nm)	1422.3	Depositor
Maximum defocus (nm)	2706.1	Depositor
Magnification	23364	Depositor
Image detector	GATAN K2 SUMMIT (4k x 4k)	Depositor
Maximum map value	13.938	Depositor
Minimum map value	-7.407	Depositor
Average map value	-0.000	Depositor
Map value standard deviation	0.938	Depositor
Recommended contour level	4.0	Depositor
Map size (Å)	548.91003, 548.91003, 548.91003	wwPDB
Map dimensions	513, 513, 513	wwPDB
Map angles (°)	90.0, 90.0, 90.0	wwPDB
Pixel spacing (Å)	1.07, 1.07, 1.07	Depositor

5 Model quality

5.1 Standard geometry

Bond lengths and bond angles in the following residue types are not validated in this section: GTP, GDP, MG

The Z score for a bond length (or angle) is the number of standard deviations the observed value is removed from the expected value. A bond length (or angle) with $|Z| > 5$ is considered an outlier worth inspection. RMSZ is the root-mean-square of all Z scores of the bond lengths (or angles).

Mol	Chain	Bond lengths		Bond angles	
		RMSZ	# Z >5	RMSZ	# Z >5
1	1A	0.33	0/3473	0.50	0/4716
1	1B	0.33	0/3473	0.50	0/4716
1	1C	0.33	0/3473	0.50	0/4716
1	1D	0.33	0/3473	0.50	0/4716
1	1E	0.33	0/3473	0.50	0/4716
1	1F	0.33	0/3473	0.50	0/4716
1	1G	0.33	0/3473	0.50	0/4716
1	1I	0.33	0/3473	0.50	0/4716
1	1J	0.33	0/3473	0.50	0/4716
1	1K	0.33	0/3473	0.50	0/4716
1	1L	0.33	0/3473	0.50	0/4716
1	1M	0.33	0/3473	0.50	0/4716
1	1N	0.33	0/3473	0.50	0/4716
1	2A	0.33	0/3473	0.50	0/4716
1	2B	0.33	0/3473	0.50	0/4716
1	2C	0.33	0/3473	0.50	0/4716
1	2D	0.33	0/3473	0.50	0/4716
1	2E	0.33	0/3473	0.50	0/4716
1	2F	0.33	0/3473	0.50	0/4716
1	2G	0.33	0/3473	0.50	0/4716
1	2I	0.33	0/3473	0.50	0/4716
1	2J	0.33	0/3473	0.50	0/4716
1	2K	0.33	0/3473	0.50	0/4716
1	2L	0.33	0/3473	0.50	0/4716
1	2M	0.33	0/3473	0.50	0/4716
1	2N	0.33	0/3473	0.50	0/4716
1	3A	0.33	0/3473	0.50	0/4716
1	3B	0.33	0/3473	0.50	0/4716
1	3C	0.33	0/3473	0.50	0/4716
1	3D	0.33	0/3473	0.51	0/4716
1	3E	0.33	0/3473	0.50	0/4716
1	3F	0.33	0/3473	0.50	0/4716

Mol	Chain	Bond lengths		Bond angles	
		RMSZ	# Z >5	RMSZ	# Z >5
1	3G	0.33	0/3473	0.50	0/4716
1	3I	0.33	0/3473	0.50	0/4716
1	3J	0.33	0/3473	0.50	0/4716
1	3K	0.33	0/3473	0.50	0/4716
1	3L	0.33	0/3473	0.50	0/4716
1	3M	0.33	0/3473	0.51	0/4716
1	3N	0.33	0/3473	0.50	0/4716
1	4A	0.33	0/3473	0.50	0/4716
1	4B	0.33	0/3473	0.50	0/4716
1	4C	0.33	0/3473	0.50	0/4716
1	4D	0.33	0/3473	0.50	0/4716
1	4E	0.33	0/3473	0.50	0/4716
1	4F	0.33	0/3473	0.51	0/4716
1	4G	0.33	0/3473	0.50	0/4716
1	4I	0.33	0/3473	0.50	0/4716
1	4J	0.33	0/3473	0.50	0/4716
1	4K	0.33	0/3473	0.50	0/4716
1	4L	0.33	0/3473	0.50	0/4716
1	4M	0.33	0/3473	0.50	0/4716
1	4N	0.33	0/3473	0.50	0/4716
2	1H	0.33	0/3443	0.52	0/4666
2	1O	0.33	0/3443	0.52	0/4666
2	1P	0.33	0/3443	0.52	0/4666
2	1Q	0.34	0/3443	0.52	0/4666
2	1R	0.33	0/3443	0.52	0/4666
2	1S	0.33	0/3443	0.52	0/4666
2	1T	0.33	0/3443	0.52	0/4666
2	1U	0.33	0/3443	0.52	0/4666
2	1V	0.33	0/3443	0.52	0/4666
2	1W	0.33	0/3443	0.52	0/4666
2	1X	0.33	0/3443	0.52	0/4666
2	1Y	0.33	0/3443	0.52	0/4666
2	1Z	0.33	0/3443	0.52	0/4666
2	2H	0.33	0/3443	0.52	0/4666
2	2O	0.33	0/3443	0.52	0/4666
2	2P	0.33	0/3443	0.52	0/4666
2	2Q	0.33	0/3443	0.52	0/4666
2	2R	0.33	0/3443	0.52	0/4666
2	2S	0.33	0/3443	0.52	0/4666
2	2T	0.34	0/3443	0.52	0/4666
2	2U	0.34	0/3443	0.52	0/4666
2	2V	0.34	0/3443	0.52	0/4666
2	2W	0.34	0/3443	0.52	0/4666

Mol	Chain	Bond lengths		Bond angles	
		RMSZ	# Z >5	RMSZ	# Z >5
2	2X	0.33	0/3443	0.52	0/4666
2	2Y	0.34	0/3443	0.52	0/4666
2	2Z	0.33	0/3443	0.52	0/4666
2	3H	0.34	0/3443	0.52	0/4666
2	3O	0.33	0/3443	0.52	0/4666
2	3P	0.33	0/3443	0.52	0/4666
2	3Q	0.33	0/3443	0.52	0/4666
2	3R	0.33	0/3443	0.52	0/4666
2	3S	0.33	0/3443	0.52	0/4666
2	3T	0.33	0/3443	0.52	0/4666
2	3U	0.33	0/3443	0.52	0/4666
2	3V	0.33	0/3443	0.52	0/4666
2	3W	0.33	0/3443	0.52	0/4666
2	3X	0.33	0/3443	0.52	0/4666
2	3Y	0.33	0/3443	0.52	0/4666
2	3Z	0.33	0/3443	0.52	0/4666
2	4H	0.34	0/3443	0.52	0/4666
2	4O	0.34	0/3443	0.52	0/4666
2	4P	0.34	0/3443	0.52	0/4666
2	4Q	0.33	0/3443	0.52	0/4666
2	4R	0.33	0/3443	0.52	0/4666
2	4S	0.33	0/3443	0.52	0/4666
2	4T	0.33	0/3443	0.52	0/4666
2	4U	0.33	0/3443	0.52	0/4666
2	4V	0.33	0/3443	0.52	0/4666
2	4W	0.33	0/3443	0.52	0/4666
2	4X	0.34	0/3443	0.52	0/4666
2	4Y	0.33	0/3443	0.52	0/4666
2	4Z	0.33	0/3443	0.52	0/4666
All	All	0.33	0/359632	0.51	0/487864

There are no bond length outliers.

There are no bond angle outliers.

There are no chirality outliers.

There are no planarity outliers.

5.2 Too-close contacts

In the following table, the Non-H and H(model) columns list the number of non-hydrogen atoms and hydrogen atoms in the chain respectively. The H(added) column lists the number of hydrogen

atoms added and optimized by MolProbity. The Clashes column lists the number of clashes within the asymmetric unit, whereas Symm-Clashes lists symmetry-related clashes.

Mol	Chain	Non-H	H(model)	H(added)	Clashes	Symm-Clashes
1	1A	3396	0	3301	252	0
1	1B	3396	0	3301	306	0
1	1C	3396	0	3301	350	0
1	1D	3396	0	3301	372	0
1	1E	3396	0	3301	387	0
1	1F	3396	0	3301	371	0
1	1G	3396	0	3301	341	0
1	1I	3396	0	3301	308	0
1	1J	3396	0	3301	260	0
1	1K	3396	0	3301	230	0
1	1L	3396	0	3301	214	0
1	1M	3396	0	3301	224	0
1	1N	3396	0	3301	223	0
1	2A	3396	0	3301	111	0
1	2B	3396	0	3301	98	0
1	2C	3396	0	3301	97	0
1	2D	3396	0	3301	110	0
1	2E	3396	0	3301	121	0
1	2F	3396	0	3301	145	0
1	2G	3396	0	3301	158	0
1	2I	3396	0	3301	180	0
1	2J	3396	0	3301	197	0
1	2K	3396	0	3300	199	0
1	2L	3396	0	3300	188	0
1	2M	3396	0	3300	179	0
1	2N	3396	0	3301	146	0
1	3A	3396	0	3301	204	0
1	3B	3396	0	3301	206	0
1	3C	3396	0	3301	207	0
1	3D	3396	0	3301	219	0
1	3E	3396	0	3301	224	0
1	3F	3396	0	3301	238	0
1	3G	3396	0	3301	233	0
1	3I	3396	0	3301	232	0
1	3J	3396	0	3301	226	0
1	3K	3396	0	3301	225	0
1	3L	3396	0	3301	212	0
1	3M	3396	0	3301	202	0
1	3N	3396	0	3301	197	0
1	4A	3396	0	3301	51	0
1	4B	3396	0	3301	50	0

Continued on next page...

Continued from previous page...

Mol	Chain	Non-H	H(model)	H(added)	Clashes	Symm-Clashes
1	4C	3396	0	3301	53	0
1	4D	3396	0	3301	53	0
1	4E	3396	0	3301	52	0
1	4F	3396	0	3301	51	0
1	4G	3396	0	3301	52	0
1	4I	3396	0	3301	53	0
1	4J	3396	0	3301	53	0
1	4K	3396	0	3301	54	0
1	4L	3396	0	3301	52	0
1	4M	3396	0	3301	46	0
1	4N	3396	0	3301	45	0
2	1H	3368	0	3246	112	0
2	1O	3368	0	3246	96	0
2	1P	3368	0	3246	94	0
2	1Q	3368	0	3246	107	0
2	1R	3368	0	3246	122	0
2	1S	3368	0	3246	148	0
2	1T	3368	0	3246	157	0
2	1U	3368	0	3246	179	0
2	1V	3368	0	3246	196	0
2	1W	3368	0	3245	199	0
2	1X	3368	0	3245	189	0
2	1Y	3368	0	3245	181	0
2	1Z	3368	0	3246	148	0
2	2H	3368	0	3246	204	0
2	2O	3368	0	3245	201	0
2	2P	3368	0	3245	203	0
2	2Q	3368	0	3245	214	0
2	2R	3368	0	3245	222	0
2	2S	3368	0	3245	238	0
2	2T	3368	0	3245	231	0
2	2U	3368	0	3245	229	0
2	2V	3368	0	3245	225	0
2	2W	3368	0	3245	223	0
2	2X	3368	0	3245	214	0
2	2Y	3368	0	3246	207	0
2	2Z	3368	0	3246	198	0
2	3H	3368	0	3246	51	0
2	3O	3368	0	3246	50	0
2	3P	3368	0	3246	51	0
2	3Q	3368	0	3246	50	0
2	3R	3368	0	3246	52	0

Continued on next page...

Continued from previous page...

Mol	Chain	Non-H	H(model)	H(added)	Clashes	Symm-Clashes
2	3S	3368	0	3246	54	0
2	3T	3368	0	3246	50	0
2	3U	3368	0	3246	52	0
2	3V	3368	0	3246	53	0
2	3W	3368	0	3246	53	0
2	3X	3368	0	3246	52	0
2	3Y	3368	0	3246	50	0
2	3Z	3368	0	3246	49	0
2	4H	3368	0	3243	250	0
2	4O	3368	0	3243	299	0
2	4P	3368	0	3243	343	0
2	4Q	3368	0	3243	367	0
2	4R	3368	0	3243	382	0
2	4S	3368	0	3243	370	0
2	4T	3368	0	3245	339	0
2	4U	3368	0	3246	307	0
2	4V	3368	0	3246	259	0
2	4W	3368	0	3246	227	0
2	4X	3368	0	3246	217	0
2	4Y	3368	0	3246	226	0
2	4Z	3368	0	3244	220	0
3	1A	32	0	12	2	0
3	1B	32	0	12	2	0
3	1C	32	0	12	2	0
3	1D	32	0	12	2	0
3	1E	32	0	12	2	0
3	1F	32	0	12	1	0
3	1G	32	0	12	2	0
3	1I	32	0	12	2	0
3	1J	32	0	12	2	0
3	1K	32	0	12	2	0
3	1L	32	0	12	2	0
3	1M	32	0	12	2	0
3	1N	32	0	12	1	0
3	2A	32	0	12	2	0
3	2B	32	0	12	2	0
3	2C	32	0	12	2	0
3	2D	32	0	12	2	0
3	2E	32	0	12	2	0
3	2F	32	0	12	2	0
3	2G	32	0	12	2	0
3	2I	32	0	12	2	0

Continued on next page...

Continued from previous page...

Mol	Chain	Non-H	H(model)	H(added)	Clashes	Symm-Clashes
3	2J	32	0	12	2	0
3	2K	32	0	12	2	0
3	2L	32	0	12	2	0
3	2M	32	0	12	2	0
3	2N	32	0	12	1	0
3	3A	32	0	12	2	0
3	3B	32	0	12	2	0
3	3C	32	0	12	2	0
3	3D	32	0	12	2	0
3	3E	32	0	12	2	0
3	3F	32	0	12	1	0
3	3G	32	0	12	2	0
3	3I	32	0	12	2	0
3	3J	32	0	12	2	0
3	3K	32	0	12	2	0
3	3L	32	0	12	2	0
3	3M	32	0	12	2	0
3	3N	32	0	12	1	0
3	4A	32	0	12	2	0
3	4B	32	0	12	2	0
3	4C	32	0	12	2	0
3	4D	32	0	12	2	0
3	4E	32	0	12	2	0
3	4F	32	0	12	2	0
3	4G	32	0	12	2	0
3	4I	32	0	12	2	0
3	4J	32	0	12	2	0
3	4K	32	0	12	2	0
3	4L	32	0	12	2	0
3	4M	32	0	12	2	0
3	4N	32	0	12	1	0
4	1A	1	0	0	0	0
4	1B	1	0	0	0	0
4	1C	1	0	0	0	0
4	1D	1	0	0	0	0
4	1E	1	0	0	0	0
4	1F	1	0	0	0	0
4	1G	1	0	0	0	0
4	1I	1	0	0	0	0
4	1J	1	0	0	0	0
4	1K	1	0	0	0	0
4	1L	1	0	0	0	0

Continued on next page...

Continued from previous page...

Mol	Chain	Non-H	H(model)	H(added)	Clashes	Symm-Clashes
4	1M	1	0	0	0	0
4	1N	1	0	0	0	0
4	2A	1	0	0	0	0
4	2B	1	0	0	0	0
4	2C	1	0	0	0	0
4	2D	1	0	0	0	0
4	2E	1	0	0	0	0
4	2F	1	0	0	0	0
4	2G	1	0	0	0	0
4	2I	1	0	0	0	0
4	2J	1	0	0	0	0
4	2K	1	0	0	0	0
4	2L	1	0	0	0	0
4	2M	1	0	0	0	0
4	2N	1	0	0	0	0
4	3A	1	0	0	0	0
4	3B	1	0	0	0	0
4	3C	1	0	0	0	0
4	3D	1	0	0	0	0
4	3E	1	0	0	0	0
4	3F	1	0	0	0	0
4	3G	1	0	0	0	0
4	3I	1	0	0	0	0
4	3J	1	0	0	0	0
4	3K	1	0	0	0	0
4	3L	1	0	0	0	0
4	3M	1	0	0	0	0
4	3N	1	0	0	0	0
4	4A	1	0	0	0	0
4	4B	1	0	0	0	0
4	4C	1	0	0	0	0
4	4D	1	0	0	0	0
4	4E	1	0	0	0	0
4	4F	1	0	0	0	0
4	4G	1	0	0	0	0
4	4I	1	0	0	0	0
4	4J	1	0	0	0	0
4	4K	1	0	0	0	0
4	4L	1	0	0	0	0
4	4M	1	0	0	0	0
4	4N	1	0	0	0	0
5	1H	28	0	12	2	0

Continued on next page...

Continued from previous page...

Mol	Chain	Non-H	H(model)	H(added)	Clashes	Symm-Clashes
5	1O	28	0	12	2	0
5	1P	28	0	12	2	0
5	1Q	28	0	12	2	0
5	1R	28	0	12	2	0
5	1S	28	0	12	2	0
5	1T	28	0	12	2	0
5	1U	28	0	12	2	0
5	1V	28	0	12	2	0
5	1W	28	0	12	2	0
5	1X	28	0	12	3	0
5	1Y	28	0	12	3	0
5	1Z	28	0	12	2	0
5	2H	28	0	12	3	0
5	2O	28	0	12	4	0
5	2P	28	0	12	5	0
5	2Q	28	0	12	5	0
5	2R	28	0	12	6	0
5	2S	28	0	12	6	0
5	2T	28	0	12	5	0
5	2U	28	0	12	5	0
5	2V	28	0	12	4	0
5	2W	28	0	12	4	0
5	2X	28	0	12	4	0
5	2Y	28	0	12	3	0
5	2Z	28	0	12	3	0
5	3H	28	0	12	2	0
5	3O	28	0	12	2	0
5	3P	28	0	12	2	0
5	3Q	28	0	12	2	0
5	3R	28	0	12	2	0
5	3S	28	0	12	2	0
5	3T	28	0	12	2	0
5	3U	28	0	12	2	0
5	3V	28	0	12	2	0
5	3W	28	0	12	2	0
5	3X	28	0	12	2	0
5	3Y	28	0	12	2	0
5	3Z	28	0	12	2	0
5	4H	28	0	12	5	0
5	4O	28	0	12	6	0
5	4P	28	0	12	7	0
5	4Q	28	0	12	6	0

Continued on next page...

Continued from previous page...

Mol	Chain	Non-H	H(model)	H(added)	Clashes	Symm-Clashes
5	4R	28	0	12	6	0
5	4S	28	0	12	6	0
5	4T	28	0	12	6	0
5	4U	28	0	12	4	0
5	4V	28	0	12	4	0
5	4W	28	0	12	4	0
5	4X	28	0	12	4	0
5	4Y	28	0	12	4	0
5	4Z	28	0	12	4	0
All	All	354900	0	341655	11466	0

The all-atom clashscore is defined as the number of clashes found per 1000 atoms (including hydrogen atoms). The all-atom clashscore for this structure is 16.

The worst 5 of 11466 close contacts within the same asymmetric unit are listed below, sorted by their clash magnitude.

Atom-1	Atom-2	Interatomic distance (Å)	Clash overlap (Å)
2:2W:406:HIS:CD2	1:3K:263:PRO:HD3	1.46	1.50
1:1G:262:TYR:HA	2:4T:406:HIS:CD2	1.47	1.49
2:2U:406:HIS:CD2	1:3I:263:PRO:HD3	1.47	1.49
2:2V:406:HIS:CD2	1:3J:263:PRO:HD3	1.45	1.49
1:1I:262:TYR:HA	2:4U:406:HIS:CD2	1.49	1.47

There are no symmetry-related clashes.

5.3 Torsion angles [i](#)

5.3.1 Protein backbone [i](#)

In the following table, the Percentiles column shows the percent Ramachandran outliers of the chain as a percentile score with respect to all PDB entries followed by that with respect to all EM entries.

The Analysed column shows the number of residues for which the backbone conformation was analysed, and the total number of residues.

Mol	Chain	Analysed	Favoured	Allowed	Outliers	Percentiles	
1	1A	430/451 (95%)	413 (96%)	17 (4%)	0	100	100
1	1B	430/451 (95%)	413 (96%)	17 (4%)	0	100	100

Continued on next page...

Continued from previous page...

Mol	Chain	Analysed	Favoured	Allowed	Outliers	Percentiles	
1	1C	430/451 (95%)	413 (96%)	17 (4%)	0	100	100
1	1D	430/451 (95%)	413 (96%)	17 (4%)	0	100	100
1	1E	430/451 (95%)	413 (96%)	17 (4%)	0	100	100
1	1F	430/451 (95%)	413 (96%)	17 (4%)	0	100	100
1	1G	430/451 (95%)	413 (96%)	17 (4%)	0	100	100
1	1I	430/451 (95%)	413 (96%)	17 (4%)	0	100	100
1	1J	430/451 (95%)	413 (96%)	17 (4%)	0	100	100
1	1K	430/451 (95%)	413 (96%)	17 (4%)	0	100	100
1	1L	430/451 (95%)	413 (96%)	17 (4%)	0	100	100
1	1M	430/451 (95%)	413 (96%)	17 (4%)	0	100	100
1	1N	430/451 (95%)	413 (96%)	17 (4%)	0	100	100
1	2A	430/451 (95%)	413 (96%)	17 (4%)	0	100	100
1	2B	430/451 (95%)	414 (96%)	16 (4%)	0	100	100
1	2C	430/451 (95%)	414 (96%)	16 (4%)	0	100	100
1	2D	430/451 (95%)	413 (96%)	17 (4%)	0	100	100
1	2E	430/451 (95%)	413 (96%)	17 (4%)	0	100	100
1	2F	430/451 (95%)	413 (96%)	17 (4%)	0	100	100
1	2G	430/451 (95%)	413 (96%)	17 (4%)	0	100	100
1	2I	430/451 (95%)	413 (96%)	17 (4%)	0	100	100
1	2J	430/451 (95%)	413 (96%)	17 (4%)	0	100	100
1	2K	430/451 (95%)	413 (96%)	17 (4%)	0	100	100
1	2L	430/451 (95%)	413 (96%)	17 (4%)	0	100	100
1	2M	430/451 (95%)	413 (96%)	17 (4%)	0	100	100
1	2N	430/451 (95%)	413 (96%)	17 (4%)	0	100	100
1	3A	430/451 (95%)	413 (96%)	17 (4%)	0	100	100
1	3B	430/451 (95%)	413 (96%)	17 (4%)	0	100	100
1	3C	430/451 (95%)	413 (96%)	17 (4%)	0	100	100
1	3D	430/451 (95%)	413 (96%)	17 (4%)	0	100	100
1	3E	430/451 (95%)	413 (96%)	17 (4%)	0	100	100
1	3F	430/451 (95%)	413 (96%)	17 (4%)	0	100	100
1	3G	430/451 (95%)	413 (96%)	17 (4%)	0	100	100

Continued on next page...

Continued from previous page...

Mol	Chain	Analysed	Favoured	Allowed	Outliers	Percentiles	
1	3I	430/451 (95%)	413 (96%)	17 (4%)	0	100	100
1	3J	430/451 (95%)	413 (96%)	17 (4%)	0	100	100
1	3K	430/451 (95%)	413 (96%)	17 (4%)	0	100	100
1	3L	430/451 (95%)	413 (96%)	17 (4%)	0	100	100
1	3M	430/451 (95%)	413 (96%)	17 (4%)	0	100	100
1	3N	430/451 (95%)	413 (96%)	17 (4%)	0	100	100
1	4A	430/451 (95%)	414 (96%)	16 (4%)	0	100	100
1	4B	430/451 (95%)	413 (96%)	17 (4%)	0	100	100
1	4C	430/451 (95%)	413 (96%)	17 (4%)	0	100	100
1	4D	430/451 (95%)	413 (96%)	17 (4%)	0	100	100
1	4E	430/451 (95%)	413 (96%)	17 (4%)	0	100	100
1	4F	430/451 (95%)	413 (96%)	17 (4%)	0	100	100
1	4G	430/451 (95%)	413 (96%)	17 (4%)	0	100	100
1	4I	430/451 (95%)	413 (96%)	17 (4%)	0	100	100
1	4J	430/451 (95%)	413 (96%)	17 (4%)	0	100	100
1	4K	430/451 (95%)	413 (96%)	17 (4%)	0	100	100
1	4L	430/451 (95%)	413 (96%)	17 (4%)	0	100	100
1	4M	430/451 (95%)	413 (96%)	17 (4%)	0	100	100
1	4N	430/451 (95%)	413 (96%)	17 (4%)	0	100	100
2	1H	427/445 (96%)	409 (96%)	18 (4%)	0	100	100
2	1O	427/445 (96%)	409 (96%)	18 (4%)	0	100	100
2	1P	427/445 (96%)	409 (96%)	18 (4%)	0	100	100
2	1Q	427/445 (96%)	409 (96%)	18 (4%)	0	100	100
2	1R	427/445 (96%)	409 (96%)	18 (4%)	0	100	100
2	1S	427/445 (96%)	409 (96%)	18 (4%)	0	100	100
2	1T	427/445 (96%)	409 (96%)	18 (4%)	0	100	100
2	1U	427/445 (96%)	409 (96%)	18 (4%)	0	100	100
2	1V	427/445 (96%)	409 (96%)	18 (4%)	0	100	100
2	1W	427/445 (96%)	409 (96%)	18 (4%)	0	100	100
2	1X	427/445 (96%)	409 (96%)	18 (4%)	0	100	100
2	1Y	427/445 (96%)	409 (96%)	18 (4%)	0	100	100

Continued on next page...

Continued from previous page...

Mol	Chain	Analysed	Favoured	Allowed	Outliers	Percentiles	
2	1Z	427/445 (96%)	409 (96%)	18 (4%)	0	100	100
2	2H	427/445 (96%)	409 (96%)	18 (4%)	0	100	100
2	2O	427/445 (96%)	409 (96%)	18 (4%)	0	100	100
2	2P	427/445 (96%)	409 (96%)	18 (4%)	0	100	100
2	2Q	427/445 (96%)	409 (96%)	18 (4%)	0	100	100
2	2R	427/445 (96%)	409 (96%)	18 (4%)	0	100	100
2	2S	427/445 (96%)	409 (96%)	18 (4%)	0	100	100
2	2T	427/445 (96%)	409 (96%)	18 (4%)	0	100	100
2	2U	427/445 (96%)	409 (96%)	18 (4%)	0	100	100
2	2V	427/445 (96%)	409 (96%)	18 (4%)	0	100	100
2	2W	427/445 (96%)	409 (96%)	18 (4%)	0	100	100
2	2X	427/445 (96%)	409 (96%)	18 (4%)	0	100	100
2	2Y	427/445 (96%)	409 (96%)	18 (4%)	0	100	100
2	2Z	427/445 (96%)	409 (96%)	18 (4%)	0	100	100
2	3H	427/445 (96%)	409 (96%)	18 (4%)	0	100	100
2	3O	427/445 (96%)	409 (96%)	18 (4%)	0	100	100
2	3P	427/445 (96%)	409 (96%)	18 (4%)	0	100	100
2	3Q	427/445 (96%)	409 (96%)	18 (4%)	0	100	100
2	3R	427/445 (96%)	409 (96%)	18 (4%)	0	100	100
2	3S	427/445 (96%)	409 (96%)	18 (4%)	0	100	100
2	3T	427/445 (96%)	409 (96%)	18 (4%)	0	100	100
2	3U	427/445 (96%)	409 (96%)	18 (4%)	0	100	100
2	3V	427/445 (96%)	409 (96%)	18 (4%)	0	100	100
2	3W	427/445 (96%)	409 (96%)	18 (4%)	0	100	100
2	3X	427/445 (96%)	409 (96%)	18 (4%)	0	100	100
2	3Y	427/445 (96%)	409 (96%)	18 (4%)	0	100	100
2	3Z	427/445 (96%)	409 (96%)	18 (4%)	0	100	100
2	4H	427/445 (96%)	409 (96%)	18 (4%)	0	100	100
2	4O	427/445 (96%)	409 (96%)	18 (4%)	0	100	100
2	4P	427/445 (96%)	409 (96%)	18 (4%)	0	100	100
2	4Q	427/445 (96%)	409 (96%)	18 (4%)	0	100	100

Continued on next page...

Continued from previous page...

Mol	Chain	Analysed	Favoured	Allowed	Outliers	Percentiles	
2	4R	427/445 (96%)	409 (96%)	18 (4%)	0	100	100
2	4S	427/445 (96%)	409 (96%)	18 (4%)	0	100	100
2	4T	427/445 (96%)	409 (96%)	18 (4%)	0	100	100
2	4U	427/445 (96%)	409 (96%)	18 (4%)	0	100	100
2	4V	427/445 (96%)	409 (96%)	18 (4%)	0	100	100
2	4W	427/445 (96%)	409 (96%)	18 (4%)	0	100	100
2	4X	427/445 (96%)	409 (96%)	18 (4%)	0	100	100
2	4Y	427/445 (96%)	409 (96%)	18 (4%)	0	100	100
2	4Z	427/445 (96%)	409 (96%)	18 (4%)	0	100	100
All	All	44564/46592 (96%)	42747 (96%)	1817 (4%)	0	100	100

There are no Ramachandran outliers to report.

5.3.2 Protein sidechains [i](#)

In the following table, the Percentiles column shows the percent sidechain outliers of the chain as a percentile score with respect to all PDB entries followed by that with respect to all EM entries.

The Analysed column shows the number of residues for which the sidechain conformation was analysed, and the total number of residues.

Mol	Chain	Analysed	Rotameric	Outliers	Percentiles	
1	1A	366/379 (97%)	365 (100%)	1 (0%)	92	95
1	1B	366/379 (97%)	365 (100%)	1 (0%)	92	95
1	1C	366/379 (97%)	365 (100%)	1 (0%)	92	95
1	1D	366/379 (97%)	365 (100%)	1 (0%)	92	95
1	1E	366/379 (97%)	365 (100%)	1 (0%)	92	95
1	1F	366/379 (97%)	365 (100%)	1 (0%)	92	95
1	1G	366/379 (97%)	365 (100%)	1 (0%)	92	95
1	1I	366/379 (97%)	365 (100%)	1 (0%)	92	95
1	1J	366/379 (97%)	365 (100%)	1 (0%)	92	95
1	1K	366/379 (97%)	365 (100%)	1 (0%)	92	95
1	1L	366/379 (97%)	365 (100%)	1 (0%)	92	95
1	1M	366/379 (97%)	365 (100%)	1 (0%)	92	95

Continued on next page...

Continued from previous page...

Mol	Chain	Analysed	Rotameric	Outliers	Percentiles	
1	1N	366/379 (97%)	365 (100%)	1 (0%)	92	95
1	2A	366/379 (97%)	365 (100%)	1 (0%)	92	95
1	2B	366/379 (97%)	365 (100%)	1 (0%)	92	95
1	2C	366/379 (97%)	365 (100%)	1 (0%)	92	95
1	2D	366/379 (97%)	365 (100%)	1 (0%)	92	95
1	2E	366/379 (97%)	365 (100%)	1 (0%)	92	95
1	2F	366/379 (97%)	365 (100%)	1 (0%)	92	95
1	2G	366/379 (97%)	365 (100%)	1 (0%)	92	95
1	2I	366/379 (97%)	365 (100%)	1 (0%)	92	95
1	2J	366/379 (97%)	365 (100%)	1 (0%)	92	95
1	2K	366/379 (97%)	365 (100%)	1 (0%)	92	95
1	2L	366/379 (97%)	365 (100%)	1 (0%)	92	95
1	2M	366/379 (97%)	365 (100%)	1 (0%)	92	95
1	2N	366/379 (97%)	365 (100%)	1 (0%)	92	95
1	3A	366/379 (97%)	365 (100%)	1 (0%)	92	95
1	3B	366/379 (97%)	365 (100%)	1 (0%)	92	95
1	3C	366/379 (97%)	365 (100%)	1 (0%)	92	95
1	3D	366/379 (97%)	365 (100%)	1 (0%)	92	95
1	3E	366/379 (97%)	365 (100%)	1 (0%)	92	95
1	3F	366/379 (97%)	365 (100%)	1 (0%)	92	95
1	3G	366/379 (97%)	365 (100%)	1 (0%)	92	95
1	3I	366/379 (97%)	365 (100%)	1 (0%)	92	95
1	3J	366/379 (97%)	365 (100%)	1 (0%)	92	95
1	3K	366/379 (97%)	365 (100%)	1 (0%)	92	95
1	3L	366/379 (97%)	365 (100%)	1 (0%)	92	95
1	3M	366/379 (97%)	365 (100%)	1 (0%)	92	95
1	3N	366/379 (97%)	365 (100%)	1 (0%)	92	95
1	4A	366/379 (97%)	365 (100%)	1 (0%)	92	95
1	4B	366/379 (97%)	365 (100%)	1 (0%)	92	95
1	4C	366/379 (97%)	365 (100%)	1 (0%)	92	95
1	4D	366/379 (97%)	365 (100%)	1 (0%)	92	95

Continued on next page...

Continued from previous page...

Mol	Chain	Analysed	Rotameric	Outliers	Percentiles	
1	4E	366/379 (97%)	365 (100%)	1 (0%)	92	95
1	4F	366/379 (97%)	365 (100%)	1 (0%)	92	95
1	4G	366/379 (97%)	365 (100%)	1 (0%)	92	95
1	4I	366/379 (97%)	365 (100%)	1 (0%)	92	95
1	4J	366/379 (97%)	365 (100%)	1 (0%)	92	95
1	4K	366/379 (97%)	365 (100%)	1 (0%)	92	95
1	4L	366/379 (97%)	365 (100%)	1 (0%)	92	95
1	4M	366/379 (97%)	365 (100%)	1 (0%)	92	95
1	4N	366/379 (97%)	365 (100%)	1 (0%)	92	95
2	1H	368/381 (97%)	367 (100%)	1 (0%)	92	95
2	1O	368/381 (97%)	367 (100%)	1 (0%)	92	95
2	1P	368/381 (97%)	367 (100%)	1 (0%)	92	95
2	1Q	368/381 (97%)	367 (100%)	1 (0%)	92	95
2	1R	368/381 (97%)	367 (100%)	1 (0%)	92	95
2	1S	368/381 (97%)	367 (100%)	1 (0%)	92	95
2	1T	368/381 (97%)	367 (100%)	1 (0%)	92	95
2	1U	368/381 (97%)	367 (100%)	1 (0%)	92	95
2	1V	368/381 (97%)	367 (100%)	1 (0%)	92	95
2	1W	368/381 (97%)	367 (100%)	1 (0%)	92	95
2	1X	368/381 (97%)	367 (100%)	1 (0%)	92	95
2	1Y	368/381 (97%)	367 (100%)	1 (0%)	92	95
2	1Z	368/381 (97%)	367 (100%)	1 (0%)	92	95
2	2H	368/381 (97%)	367 (100%)	1 (0%)	92	95
2	2O	368/381 (97%)	367 (100%)	1 (0%)	92	95
2	2P	368/381 (97%)	367 (100%)	1 (0%)	92	95
2	2Q	368/381 (97%)	367 (100%)	1 (0%)	92	95
2	2R	368/381 (97%)	367 (100%)	1 (0%)	92	95
2	2S	368/381 (97%)	367 (100%)	1 (0%)	92	95
2	2T	368/381 (97%)	367 (100%)	1 (0%)	92	95
2	2U	368/381 (97%)	367 (100%)	1 (0%)	92	95
2	2V	368/381 (97%)	367 (100%)	1 (0%)	92	95

Continued on next page...

Continued from previous page...

Mol	Chain	Analysed	Rotameric	Outliers	Percentiles	
2	2W	368/381 (97%)	367 (100%)	1 (0%)	92	95
2	2X	368/381 (97%)	367 (100%)	1 (0%)	92	95
2	2Y	368/381 (97%)	367 (100%)	1 (0%)	92	95
2	2Z	368/381 (97%)	367 (100%)	1 (0%)	92	95
2	3H	368/381 (97%)	367 (100%)	1 (0%)	92	95
2	3O	368/381 (97%)	367 (100%)	1 (0%)	92	95
2	3P	368/381 (97%)	367 (100%)	1 (0%)	92	95
2	3Q	368/381 (97%)	367 (100%)	1 (0%)	92	95
2	3R	368/381 (97%)	367 (100%)	1 (0%)	92	95
2	3S	368/381 (97%)	367 (100%)	1 (0%)	92	95
2	3T	368/381 (97%)	367 (100%)	1 (0%)	92	95
2	3U	368/381 (97%)	367 (100%)	1 (0%)	92	95
2	3V	368/381 (97%)	367 (100%)	1 (0%)	92	95
2	3W	368/381 (97%)	367 (100%)	1 (0%)	92	95
2	3X	368/381 (97%)	367 (100%)	1 (0%)	92	95
2	3Y	368/381 (97%)	367 (100%)	1 (0%)	92	95
2	3Z	368/381 (97%)	367 (100%)	1 (0%)	92	95
2	4H	368/381 (97%)	367 (100%)	1 (0%)	92	95
2	4O	368/381 (97%)	367 (100%)	1 (0%)	92	95
2	4P	368/381 (97%)	367 (100%)	1 (0%)	92	95
2	4Q	368/381 (97%)	367 (100%)	1 (0%)	92	95
2	4R	368/381 (97%)	367 (100%)	1 (0%)	92	95
2	4S	368/381 (97%)	367 (100%)	1 (0%)	92	95
2	4T	368/381 (97%)	367 (100%)	1 (0%)	92	95
2	4U	368/381 (97%)	367 (100%)	1 (0%)	92	95
2	4V	368/381 (97%)	367 (100%)	1 (0%)	92	95
2	4W	368/381 (97%)	367 (100%)	1 (0%)	92	95
2	4X	368/381 (97%)	367 (100%)	1 (0%)	92	95
2	4Y	368/381 (97%)	367 (100%)	1 (0%)	92	95
2	4Z	368/381 (97%)	367 (100%)	1 (0%)	92	95
All	All	38168/39520 (97%)	38064 (100%)	104 (0%)	92	95

5 of 104 residues with a non-rotameric sidechain are listed below:

Mol	Chain	Res	Type
1	3F	339	ARG
2	3T	300	ASN
2	4V	300	ASN
1	3I	339	ARG
2	3H	300	ASN

Sometimes sidechains can be flipped to improve hydrogen bonding and reduce clashes. 5 of 794 such sidechains are listed below:

Mol	Chain	Res	Type
1	3J	15	GLN
2	3W	192	HIS
1	3L	8	HIS
1	3J	8	HIS
2	3P	336	GLN

5.3.3 RNA [i](#)

There are no RNA molecules in this entry.

5.4 Non-standard residues in protein, DNA, RNA chains [i](#)

There are no non-standard protein/DNA/RNA residues in this entry.

5.5 Carbohydrates [i](#)

There are no monosaccharides in this entry.

5.6 Ligand geometry [i](#)

Of 156 ligands modelled in this entry, 52 are monoatomic - leaving 104 for Mogul analysis.

In the following table, the Counts columns list the number of bonds (or angles) for which Mogul statistics could be retrieved, the number of bonds (or angles) that are observed in the model and the number of bonds (or angles) that are defined in the Chemical Component Dictionary. The Link column lists molecule types, if any, to which the group is linked. The Z score for a bond length (or angle) is the number of standard deviations the observed value is removed from the expected value. A bond length (or angle) with $|Z| > 2$ is considered an outlier worth inspection. RMSZ is the root-mean-square of all Z scores of the bond lengths (or angles).

Mol	Type	Chain	Res	Link	Bond lengths			Bond angles		
					Counts	RMSZ	# Z > 2	Counts	RMSZ	# Z > 2
5	GDP	3X	501	-	24,30,30	1.00	1 (4%)	30,47,47	1.22	4 (13%)
5	GDP	1R	501	-	24,30,30	1.00	1 (4%)	30,47,47	1.22	4 (13%)
3	GTP	2I	501	4	26,34,34	1.20	1 (3%)	32,54,54	1.65	6 (18%)
5	GDP	2S	501	-	24,30,30	1.00	1 (4%)	30,47,47	1.22	4 (13%)
3	GTP	4J	501	4	26,34,34	1.21	1 (3%)	32,54,54	1.65	6 (18%)
3	GTP	2M	501	4	26,34,34	1.20	1 (3%)	32,54,54	1.66	7 (21%)
5	GDP	4X	501	-	24,30,30	0.99	1 (4%)	30,47,47	1.22	4 (13%)
5	GDP	1X	501	-	24,30,30	0.99	1 (4%)	30,47,47	1.22	4 (13%)
5	GDP	2T	501	-	24,30,30	1.00	1 (4%)	30,47,47	1.22	4 (13%)
3	GTP	2A	501	4	26,34,34	1.20	1 (3%)	32,54,54	1.65	7 (21%)
3	GTP	2C	501	4	26,34,34	1.19	1 (3%)	32,54,54	1.65	7 (21%)
3	GTP	4D	501	4	26,34,34	1.20	1 (3%)	32,54,54	1.66	7 (21%)
3	GTP	2D	501	4	26,34,34	1.20	1 (3%)	32,54,54	1.65	6 (18%)
5	GDP	1V	501	-	24,30,30	1.00	1 (4%)	30,47,47	1.22	4 (13%)
3	GTP	3C	501	4	26,34,34	1.20	1 (3%)	32,54,54	1.65	6 (18%)
5	GDP	2O	501	-	24,30,30	0.99	1 (4%)	30,47,47	1.22	4 (13%)
3	GTP	4L	501	4	26,34,34	1.20	1 (3%)	32,54,54	1.65	6 (18%)
5	GDP	3P	501	-	24,30,30	1.00	1 (4%)	30,47,47	1.22	4 (13%)
3	GTP	4E	501	4	26,34,34	1.19	1 (3%)	32,54,54	1.65	7 (21%)
3	GTP	3M	501	4	26,34,34	1.20	1 (3%)	32,54,54	1.65	7 (21%)
3	GTP	1N	501	4	26,34,34	1.20	1 (3%)	32,54,54	1.65	7 (21%)
5	GDP	3W	501	-	24,30,30	1.00	1 (4%)	30,47,47	1.22	4 (13%)
5	GDP	4W	501	-	24,30,30	1.00	1 (4%)	30,47,47	1.22	4 (13%)
5	GDP	4R	501	-	24,30,30	1.00	1 (4%)	30,47,47	1.22	4 (13%)
5	GDP	4U	501	-	24,30,30	1.01	1 (4%)	30,47,47	1.22	4 (13%)
3	GTP	3I	501	4	26,34,34	1.20	1 (3%)	32,54,54	1.66	7 (21%)
5	GDP	1O	501	-	24,30,30	1.00	1 (4%)	30,47,47	1.23	4 (13%)
5	GDP	1H	501	-	24,30,30	1.00	1 (4%)	30,47,47	1.22	4 (13%)
5	GDP	4Y	501	-	24,30,30	1.00	1 (4%)	30,47,47	1.22	4 (13%)
5	GDP	1U	501	-	24,30,30	1.01	1 (4%)	30,47,47	1.22	4 (13%)
3	GTP	1F	501	4	26,34,34	1.20	1 (3%)	32,54,54	1.65	7 (21%)
3	GTP	4F	501	4	26,34,34	1.20	1 (3%)	32,54,54	1.65	7 (21%)
3	GTP	3G	501	4	26,34,34	1.20	1 (3%)	32,54,54	1.65	7 (21%)
3	GTP	1K	501	4	26,34,34	1.20	1 (3%)	32,54,54	1.65	7 (21%)
3	GTP	4A	501	4	26,34,34	1.21	1 (3%)	32,54,54	1.65	7 (21%)

Mol	Type	Chain	Res	Link	Bond lengths			Bond angles		
					Counts	RMSZ	# Z > 2	Counts	RMSZ	# Z > 2
3	GTP	3E	501	4	26,34,34	1.20	1 (3%)	32,54,54	1.65	7 (21%)
5	GDP	2P	501	-	24,30,30	1.00	1 (4%)	30,47,47	1.22	4 (13%)
5	GDP	1S	501	-	24,30,30	1.00	1 (4%)	30,47,47	1.22	4 (13%)
3	GTP	4G	501	4	26,34,34	1.21	1 (3%)	32,54,54	1.66	6 (18%)
5	GDP	1Y	501	-	24,30,30	1.00	1 (4%)	30,47,47	1.22	4 (13%)
5	GDP	3T	501	-	24,30,30	0.99	1 (4%)	30,47,47	1.22	4 (13%)
3	GTP	2E	501	4	26,34,34	1.20	1 (3%)	32,54,54	1.65	7 (21%)
3	GTP	4C	501	4	26,34,34	1.20	1 (3%)	32,54,54	1.65	7 (21%)
5	GDP	2Y	501	-	24,30,30	1.00	1 (4%)	30,47,47	1.22	4 (13%)
3	GTP	1M	501	4	26,34,34	1.20	1 (3%)	32,54,54	1.65	7 (21%)
5	GDP	3V	501	-	24,30,30	1.00	1 (4%)	30,47,47	1.23	4 (13%)
5	GDP	2X	501	-	24,30,30	1.00	1 (4%)	30,47,47	1.22	4 (13%)
3	GTP	3F	501	4	26,34,34	1.20	1 (3%)	32,54,54	1.65	6 (18%)
3	GTP	3K	501	4	26,34,34	1.20	1 (3%)	32,54,54	1.65	7 (21%)
5	GDP	4P	501	-	24,30,30	1.00	1 (4%)	30,47,47	1.22	4 (13%)
3	GTP	3A	501	4	26,34,34	1.20	1 (3%)	32,54,54	1.65	6 (18%)
3	GTP	3J	501	4	26,34,34	1.19	1 (3%)	32,54,54	1.66	7 (21%)
5	GDP	1Q	501	-	24,30,30	0.99	1 (4%)	30,47,47	1.22	4 (13%)
5	GDP	2U	501	-	24,30,30	1.00	1 (4%)	30,47,47	1.22	4 (13%)
5	GDP	3O	501	-	24,30,30	1.01	1 (4%)	30,47,47	1.23	4 (13%)
3	GTP	2F	501	4	26,34,34	1.20	1 (3%)	32,54,54	1.66	7 (21%)
3	GTP	2G	501	4	26,34,34	1.20	1 (3%)	32,54,54	1.66	6 (18%)
3	GTP	3L	501	4	26,34,34	1.20	1 (3%)	32,54,54	1.65	7 (21%)
3	GTP	1J	501	4	26,34,34	1.20	1 (3%)	32,54,54	1.65	6 (18%)
5	GDP	2Z	501	-	24,30,30	1.00	1 (4%)	30,47,47	1.22	4 (13%)
5	GDP	3H	501	-	24,30,30	1.00	1 (4%)	30,47,47	1.22	4 (13%)
5	GDP	3U	501	-	24,30,30	1.01	1 (4%)	30,47,47	1.23	4 (13%)
3	GTP	4B	501	4	26,34,34	1.21	1 (3%)	32,54,54	1.65	6 (18%)
3	GTP	1A	501	4	26,34,34	1.20	1 (3%)	32,54,54	1.65	7 (21%)
5	GDP	4Q	501	-	24,30,30	1.00	1 (4%)	30,47,47	1.22	4 (13%)
5	GDP	2Q	501	-	24,30,30	1.00	1 (4%)	30,47,47	1.23	4 (13%)
5	GDP	3Z	501	-	24,30,30	0.99	1 (4%)	30,47,47	1.22	4 (13%)
3	GTP	1G	501	4	26,34,34	1.21	1 (3%)	32,54,54	1.65	6 (18%)
3	GTP	3D	501	4	26,34,34	1.21	1 (3%)	32,54,54	1.65	7 (21%)
3	GTP	1C	501	4	26,34,34	1.19	1 (3%)	32,54,54	1.65	6 (18%)

Mol	Type	Chain	Res	Link	Bond lengths			Bond angles		
					Counts	RMSZ	# Z > 2	Counts	RMSZ	# Z > 2
5	GDP	1Z	501	-	24,30,30	1.00	1 (4%)	30,47,47	1.22	4 (13%)
5	GDP	1W	501	-	24,30,30	1.00	1 (4%)	30,47,47	1.22	4 (13%)
5	GDP	4Z	501	-	24,30,30	1.00	1 (4%)	30,47,47	1.22	4 (13%)
3	GTP	1B	501	4	26,34,34	1.20	1 (3%)	32,54,54	1.66	7 (21%)
3	GTP	4I	501	4	26,34,34	1.20	1 (3%)	32,54,54	1.65	7 (21%)
3	GTP	4K	501	4	26,34,34	1.20	1 (3%)	32,54,54	1.65	7 (21%)
3	GTP	2J	501	4	26,34,34	1.21	1 (3%)	32,54,54	1.66	7 (21%)
5	GDP	3Q	501	-	24,30,30	0.99	1 (4%)	30,47,47	1.22	4 (13%)
5	GDP	2H	501	-	24,30,30	0.99	1 (4%)	30,47,47	1.22	4 (13%)
3	GTP	2B	501	4	26,34,34	1.20	1 (3%)	32,54,54	1.65	6 (18%)
5	GDP	4V	501	-	24,30,30	1.01	1 (4%)	30,47,47	1.22	4 (13%)
5	GDP	1T	501	-	24,30,30	1.00	1 (4%)	30,47,47	1.22	4 (13%)
5	GDP	4H	501	-	24,30,30	1.00	1 (4%)	30,47,47	1.22	4 (13%)
5	GDP	2W	501	-	24,30,30	1.00	1 (4%)	30,47,47	1.22	4 (13%)
3	GTP	3B	501	4	26,34,34	1.20	1 (3%)	32,54,54	1.65	6 (18%)
5	GDP	2R	501	-	24,30,30	1.00	1 (4%)	30,47,47	1.23	4 (13%)
5	GDP	3Y	501	-	24,30,30	1.00	1 (4%)	30,47,47	1.22	4 (13%)
5	GDP	3R	501	-	24,30,30	1.00	1 (4%)	30,47,47	1.22	4 (13%)
3	GTP	4N	501	4	26,34,34	1.20	1 (3%)	32,54,54	1.66	7 (21%)
3	GTP	2K	501	4	26,34,34	1.20	1 (3%)	32,54,54	1.65	7 (21%)
3	GTP	4M	501	4	26,34,34	1.21	1 (3%)	32,54,54	1.65	6 (18%)
3	GTP	2L	501	4	26,34,34	1.20	1 (3%)	32,54,54	1.65	7 (21%)
3	GTP	1I	501	4	26,34,34	1.20	1 (3%)	32,54,54	1.65	6 (18%)
5	GDP	4S	501	-	24,30,30	1.01	1 (4%)	30,47,47	1.23	4 (13%)
5	GDP	2V	501	-	24,30,30	1.02	1 (4%)	30,47,47	1.22	4 (13%)
3	GTP	1L	501	4	26,34,34	1.21	1 (3%)	32,54,54	1.65	6 (18%)
3	GTP	3N	501	4	26,34,34	1.20	1 (3%)	32,54,54	1.65	7 (21%)
5	GDP	4O	501	-	24,30,30	1.00	1 (4%)	30,47,47	1.22	4 (13%)
3	GTP	1E	501	4	26,34,34	1.20	1 (3%)	32,54,54	1.65	7 (21%)
5	GDP	1P	501	-	24,30,30	1.00	1 (4%)	30,47,47	1.22	4 (13%)
5	GDP	4T	501	-	24,30,30	0.99	1 (4%)	30,47,47	1.22	4 (13%)
3	GTP	1D	501	4	26,34,34	1.20	1 (3%)	32,54,54	1.65	7 (21%)
5	GDP	3S	501	-	24,30,30	1.00	1 (4%)	30,47,47	1.22	4 (13%)
3	GTP	2N	501	4	26,34,34	1.21	1 (3%)	32,54,54	1.65	6 (18%)

In the following table, the Chirals column lists the number of chiral outliers, the number of chiral centers analysed, the number of these observed in the model and the number defined in the Chemical Component Dictionary. Similar counts are reported in the Torsion and Rings columns. '-' means no outliers of that kind were identified.

Mol	Type	Chain	Res	Link	Chirals	Torsions	Rings
5	GDP	3X	501	-	-	3/12/32/32	0/3/3/3
5	GDP	1R	501	-	-	3/12/32/32	0/3/3/3
3	GTP	2I	501	4	-	7/18/38/38	0/3/3/3
5	GDP	2S	501	-	-	3/12/32/32	0/3/3/3
3	GTP	4J	501	4	-	7/18/38/38	0/3/3/3
3	GTP	2M	501	4	-	7/18/38/38	0/3/3/3
5	GDP	4X	501	-	-	3/12/32/32	0/3/3/3
5	GDP	1X	501	-	-	3/12/32/32	0/3/3/3
5	GDP	2T	501	-	-	3/12/32/32	0/3/3/3
3	GTP	2A	501	4	-	7/18/38/38	0/3/3/3
3	GTP	2C	501	4	-	7/18/38/38	0/3/3/3
3	GTP	4D	501	4	-	7/18/38/38	0/3/3/3
3	GTP	2D	501	4	-	7/18/38/38	0/3/3/3
5	GDP	1V	501	-	-	3/12/32/32	0/3/3/3
3	GTP	3C	501	4	-	7/18/38/38	0/3/3/3
5	GDP	2O	501	-	-	3/12/32/32	0/3/3/3
3	GTP	4L	501	4	-	7/18/38/38	0/3/3/3
5	GDP	3P	501	-	-	3/12/32/32	0/3/3/3
3	GTP	4E	501	4	-	7/18/38/38	0/3/3/3
3	GTP	3M	501	4	-	7/18/38/38	0/3/3/3
3	GTP	1N	501	4	-	7/18/38/38	0/3/3/3
5	GDP	3W	501	-	-	3/12/32/32	0/3/3/3
5	GDP	4W	501	-	-	3/12/32/32	0/3/3/3
5	GDP	4R	501	-	-	3/12/32/32	0/3/3/3
5	GDP	4U	501	-	-	3/12/32/32	0/3/3/3
3	GTP	3I	501	4	-	7/18/38/38	0/3/3/3
5	GDP	1O	501	-	-	3/12/32/32	0/3/3/3
5	GDP	1H	501	-	-	3/12/32/32	0/3/3/3
5	GDP	4Y	501	-	-	3/12/32/32	0/3/3/3
5	GDP	1U	501	-	-	3/12/32/32	0/3/3/3
3	GTP	1F	501	4	-	7/18/38/38	0/3/3/3

Continued on next page...

Continued from previous page...

Mol	Type	Chain	Res	Link	Chirals	Torsions	Rings
3	GTP	4F	501	4	-	7/18/38/38	0/3/3/3
3	GTP	3G	501	4	-	7/18/38/38	0/3/3/3
3	GTP	1K	501	4	-	7/18/38/38	0/3/3/3
3	GTP	4A	501	4	-	7/18/38/38	0/3/3/3
3	GTP	3E	501	4	-	7/18/38/38	0/3/3/3
5	GDP	2P	501	-	-	3/12/32/32	0/3/3/3
5	GDP	1S	501	-	-	3/12/32/32	0/3/3/3
3	GTP	4G	501	4	-	7/18/38/38	0/3/3/3
5	GDP	1Y	501	-	-	3/12/32/32	0/3/3/3
5	GDP	3T	501	-	-	3/12/32/32	0/3/3/3
3	GTP	2E	501	4	-	7/18/38/38	0/3/3/3
3	GTP	4C	501	4	-	7/18/38/38	0/3/3/3
5	GDP	2Y	501	-	-	3/12/32/32	0/3/3/3
3	GTP	1M	501	4	-	7/18/38/38	0/3/3/3
5	GDP	3V	501	-	-	3/12/32/32	0/3/3/3
5	GDP	2X	501	-	-	3/12/32/32	0/3/3/3
3	GTP	3F	501	4	-	7/18/38/38	0/3/3/3
3	GTP	3K	501	4	-	7/18/38/38	0/3/3/3
5	GDP	4P	501	-	-	3/12/32/32	0/3/3/3
3	GTP	3A	501	4	-	7/18/38/38	0/3/3/3
3	GTP	3J	501	4	-	7/18/38/38	0/3/3/3
5	GDP	1Q	501	-	-	3/12/32/32	0/3/3/3
5	GDP	2U	501	-	-	3/12/32/32	0/3/3/3
5	GDP	3O	501	-	-	3/12/32/32	0/3/3/3
3	GTP	2F	501	4	-	7/18/38/38	0/3/3/3
3	GTP	2G	501	4	-	7/18/38/38	0/3/3/3
3	GTP	3L	501	4	-	7/18/38/38	0/3/3/3
3	GTP	1J	501	4	-	7/18/38/38	0/3/3/3
5	GDP	2Z	501	-	-	3/12/32/32	0/3/3/3
5	GDP	3H	501	-	-	3/12/32/32	0/3/3/3
5	GDP	3U	501	-	-	3/12/32/32	0/3/3/3
3	GTP	4B	501	4	-	7/18/38/38	0/3/3/3
3	GTP	1A	501	4	-	7/18/38/38	0/3/3/3
5	GDP	4Q	501	-	-	3/12/32/32	0/3/3/3

Continued on next page...

Continued from previous page...

Mol	Type	Chain	Res	Link	Chirals	Torsions	Rings
5	GDP	2Q	501	-	-	3/12/32/32	0/3/3/3
5	GDP	3Z	501	-	-	3/12/32/32	0/3/3/3
3	GTP	1G	501	4	-	7/18/38/38	0/3/3/3
3	GTP	3D	501	4	-	7/18/38/38	0/3/3/3
3	GTP	1C	501	4	-	7/18/38/38	0/3/3/3
5	GDP	1Z	501	-	-	3/12/32/32	0/3/3/3
5	GDP	1W	501	-	-	3/12/32/32	0/3/3/3
5	GDP	4Z	501	-	-	3/12/32/32	0/3/3/3
3	GTP	1B	501	4	-	7/18/38/38	0/3/3/3
3	GTP	4I	501	4	-	7/18/38/38	0/3/3/3
3	GTP	4K	501	4	-	7/18/38/38	0/3/3/3
3	GTP	2J	501	4	-	7/18/38/38	0/3/3/3
5	GDP	3Q	501	-	-	3/12/32/32	0/3/3/3
5	GDP	2H	501	-	-	3/12/32/32	0/3/3/3
3	GTP	2B	501	4	-	7/18/38/38	0/3/3/3
5	GDP	4V	501	-	-	3/12/32/32	0/3/3/3
5	GDP	1T	501	-	-	3/12/32/32	0/3/3/3
5	GDP	4H	501	-	-	3/12/32/32	0/3/3/3
5	GDP	2W	501	-	-	3/12/32/32	0/3/3/3
3	GTP	3B	501	4	-	7/18/38/38	0/3/3/3
5	GDP	2R	501	-	-	3/12/32/32	0/3/3/3
5	GDP	3Y	501	-	-	3/12/32/32	0/3/3/3
5	GDP	3R	501	-	-	3/12/32/32	0/3/3/3
3	GTP	4N	501	4	-	7/18/38/38	0/3/3/3
3	GTP	2K	501	4	-	7/18/38/38	0/3/3/3
3	GTP	4M	501	4	-	7/18/38/38	0/3/3/3
3	GTP	2L	501	4	-	7/18/38/38	0/3/3/3
3	GTP	1I	501	4	-	7/18/38/38	0/3/3/3
5	GDP	4S	501	-	-	3/12/32/32	0/3/3/3
5	GDP	2V	501	-	-	3/12/32/32	0/3/3/3
3	GTP	1L	501	4	-	7/18/38/38	0/3/3/3
3	GTP	3N	501	4	-	7/18/38/38	0/3/3/3
5	GDP	4O	501	-	-	3/12/32/32	0/3/3/3
3	GTP	1E	501	4	-	7/18/38/38	0/3/3/3

Continued on next page...

Continued from previous page...

Mol	Type	Chain	Res	Link	Chirals	Torsions	Rings
5	GDP	1P	501	-	-	3/12/32/32	0/3/3/3
5	GDP	4T	501	-	-	3/12/32/32	0/3/3/3
3	GTP	1D	501	4	-	7/18/38/38	0/3/3/3
5	GDP	3S	501	-	-	3/12/32/32	0/3/3/3
3	GTP	2N	501	4	-	7/18/38/38	0/3/3/3

The worst 5 of 104 bond length outliers are listed below:

Mol	Chain	Res	Type	Atoms	Z	Observed(Å)	Ideal(Å)
3	4J	501	GTP	C5-C6	-4.23	1.38	1.47
3	2G	501	GTP	C5-C6	-4.22	1.38	1.47
3	1G	501	GTP	C5-C6	-4.22	1.38	1.47
3	4G	501	GTP	C5-C6	-4.22	1.38	1.47
3	2J	501	GTP	C5-C6	-4.22	1.38	1.47

The worst 5 of 553 bond angle outliers are listed below:

Mol	Chain	Res	Type	Atoms	Z	Observed(°)	Ideal(°)
3	1E	501	GTP	PB-O3B-PG	-3.79	119.81	132.83
3	3K	501	GTP	PB-O3B-PG	-3.79	119.81	132.83
3	1M	501	GTP	PB-O3B-PG	-3.79	119.81	132.83
3	4N	501	GTP	PB-O3B-PG	-3.79	119.81	132.83
3	2E	501	GTP	PB-O3B-PG	-3.79	119.81	132.83

There are no chirality outliers.

5 of 520 torsion outliers are listed below:

Mol	Chain	Res	Type	Atoms
3	1A	501	GTP	C5'-O5'-PA-O1A
3	1B	501	GTP	C5'-O5'-PA-O1A
3	1C	501	GTP	C5'-O5'-PA-O1A
3	1D	501	GTP	C5'-O5'-PA-O1A
3	1E	501	GTP	C5'-O5'-PA-O1A

There are no ring outliers.

104 monomers are involved in 275 short contacts:

Mol	Chain	Res	Type	Clashes	Symm-Clashes
5	3X	501	GDP	2	0
5	1R	501	GDP	2	0

Continued on next page...

Continued from previous page...

Mol	Chain	Res	Type	Clashes	Symm-Clashes
3	2I	501	GTP	2	0
5	2S	501	GDP	6	0
3	4J	501	GTP	2	0
3	2M	501	GTP	2	0
5	4X	501	GDP	4	0
5	1X	501	GDP	3	0
5	2T	501	GDP	5	0
3	2A	501	GTP	2	0
3	2C	501	GTP	2	0
3	4D	501	GTP	2	0
3	2D	501	GTP	2	0
5	1V	501	GDP	2	0
3	3C	501	GTP	2	0
5	2O	501	GDP	4	0
3	4L	501	GTP	2	0
5	3P	501	GDP	2	0
3	4E	501	GTP	2	0
3	3M	501	GTP	2	0
3	1N	501	GTP	1	0
5	3W	501	GDP	2	0
5	4W	501	GDP	4	0
5	4R	501	GDP	6	0
5	4U	501	GDP	4	0
3	3I	501	GTP	2	0
5	1O	501	GDP	2	0
5	1H	501	GDP	2	0
5	4Y	501	GDP	4	0
5	1U	501	GDP	2	0
3	1F	501	GTP	1	0
3	4F	501	GTP	2	0
3	3G	501	GTP	2	0
3	1K	501	GTP	2	0
3	4A	501	GTP	2	0
3	3E	501	GTP	2	0
5	2P	501	GDP	5	0
5	1S	501	GDP	2	0
3	4G	501	GTP	2	0
5	1Y	501	GDP	3	0
5	3T	501	GDP	2	0
3	2E	501	GTP	2	0
3	4C	501	GTP	2	0
5	2Y	501	GDP	3	0

Continued on next page...

Continued from previous page...

Mol	Chain	Res	Type	Clashes	Symm-Clashes
3	1M	501	GTP	2	0
5	3V	501	GDP	2	0
5	2X	501	GDP	4	0
3	3F	501	GTP	1	0
3	3K	501	GTP	2	0
5	4P	501	GDP	7	0
3	3A	501	GTP	2	0
3	3J	501	GTP	2	0
5	1Q	501	GDP	2	0
5	2U	501	GDP	5	0
5	3O	501	GDP	2	0
3	2F	501	GTP	2	0
3	2G	501	GTP	2	0
3	3L	501	GTP	2	0
3	1J	501	GTP	2	0
5	2Z	501	GDP	3	0
5	3H	501	GDP	2	0
5	3U	501	GDP	2	0
3	4B	501	GTP	2	0
3	1A	501	GTP	2	0
5	4Q	501	GDP	6	0
5	2Q	501	GDP	5	0
5	3Z	501	GDP	2	0
3	1G	501	GTP	2	0
3	3D	501	GTP	2	0
3	1C	501	GTP	2	0
5	1Z	501	GDP	2	0
5	1W	501	GDP	2	0
5	4Z	501	GDP	4	0
3	1B	501	GTP	2	0
3	4I	501	GTP	2	0
3	4K	501	GTP	2	0
3	2J	501	GTP	2	0
5	3Q	501	GDP	2	0
5	2H	501	GDP	3	0
3	2B	501	GTP	2	0
5	4V	501	GDP	4	0
5	1T	501	GDP	2	0
5	4H	501	GDP	5	0
5	2W	501	GDP	4	0
3	3B	501	GTP	2	0
5	2R	501	GDP	6	0

Continued on next page...

Continued from previous page...

Mol	Chain	Res	Type	Clashes	Symm-Clashes
5	3Y	501	GDP	2	0
5	3R	501	GDP	2	0
3	4N	501	GTP	1	0
3	2K	501	GTP	2	0
3	4M	501	GTP	2	0
3	2L	501	GTP	2	0
3	1I	501	GTP	2	0
5	4S	501	GDP	6	0
5	2V	501	GDP	4	0
3	1L	501	GTP	2	0
3	3N	501	GTP	1	0
5	4O	501	GDP	6	0
3	1E	501	GTP	2	0
5	1P	501	GDP	2	0
5	4T	501	GDP	6	0
3	1D	501	GTP	2	0
5	3S	501	GDP	2	0
3	2N	501	GTP	1	0

The following is a two-dimensional graphical depiction of Mogul quality analysis of bond lengths, bond angles, torsion angles, and ring geometry for all instances of the Ligand of Interest. In addition, ligands with molecular weight > 250 and outliers as shown on the validation Tables will also be included. For torsion angles, if less than 5% of the Mogul distribution of torsion angles is within 10 degrees of the torsion angle in question, then that torsion angle is considered an outlier. Any bond that is central to one or more torsion angles identified as an outlier by Mogul will be highlighted in the graph. For rings, the root-mean-square deviation (RMSD) between the ring in question and similar rings identified by Mogul is calculated over all ring torsion angles. If the average RMSD is greater than 60 degrees and the minimal RMSD between the ring in question and any Mogul-identified rings is also greater than 60 degrees, then that ring is considered an outlier. The outliers are highlighted in purple. The color gray indicates Mogul did not find sufficient equivalents in the CSD to analyse the geometry.

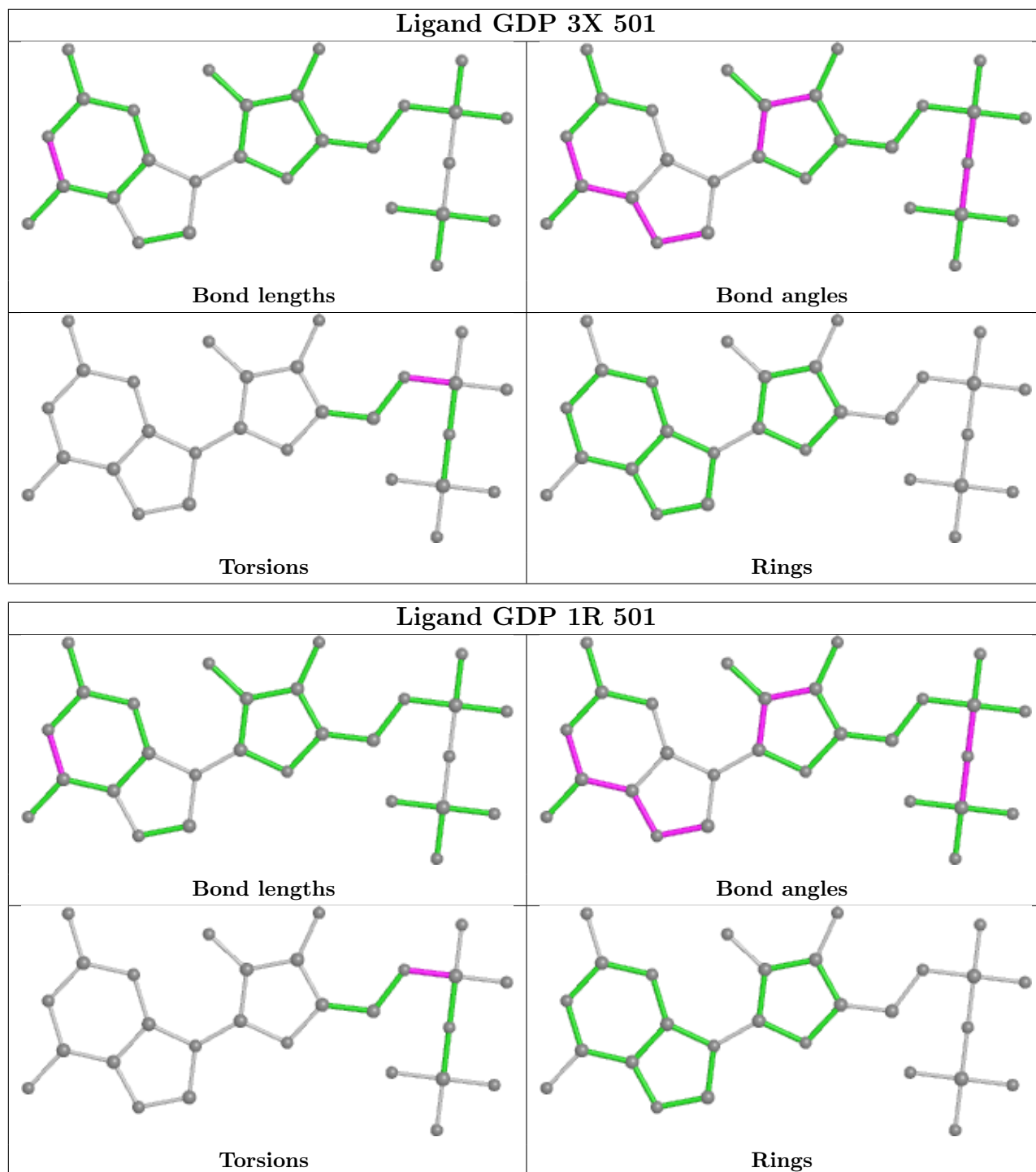

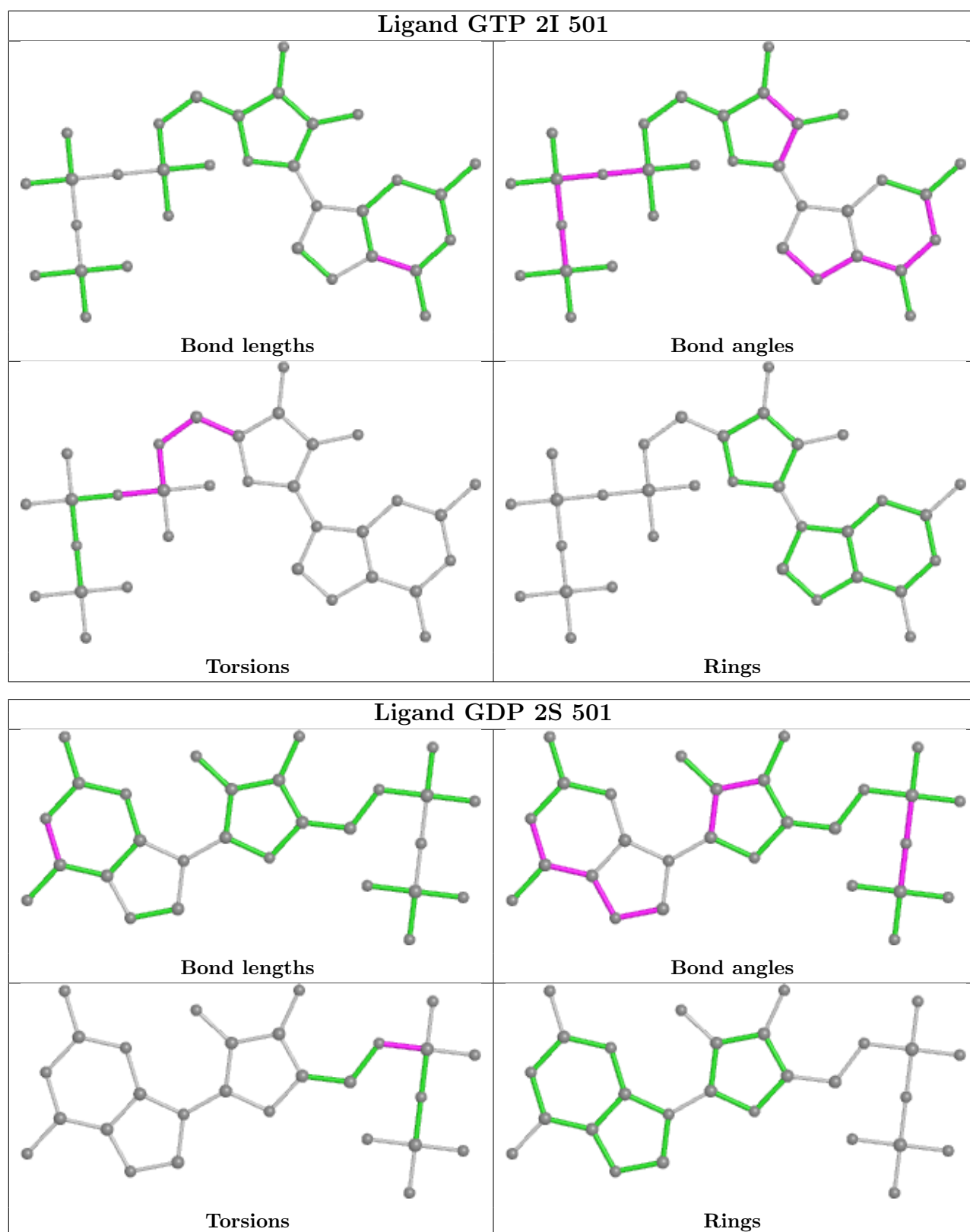

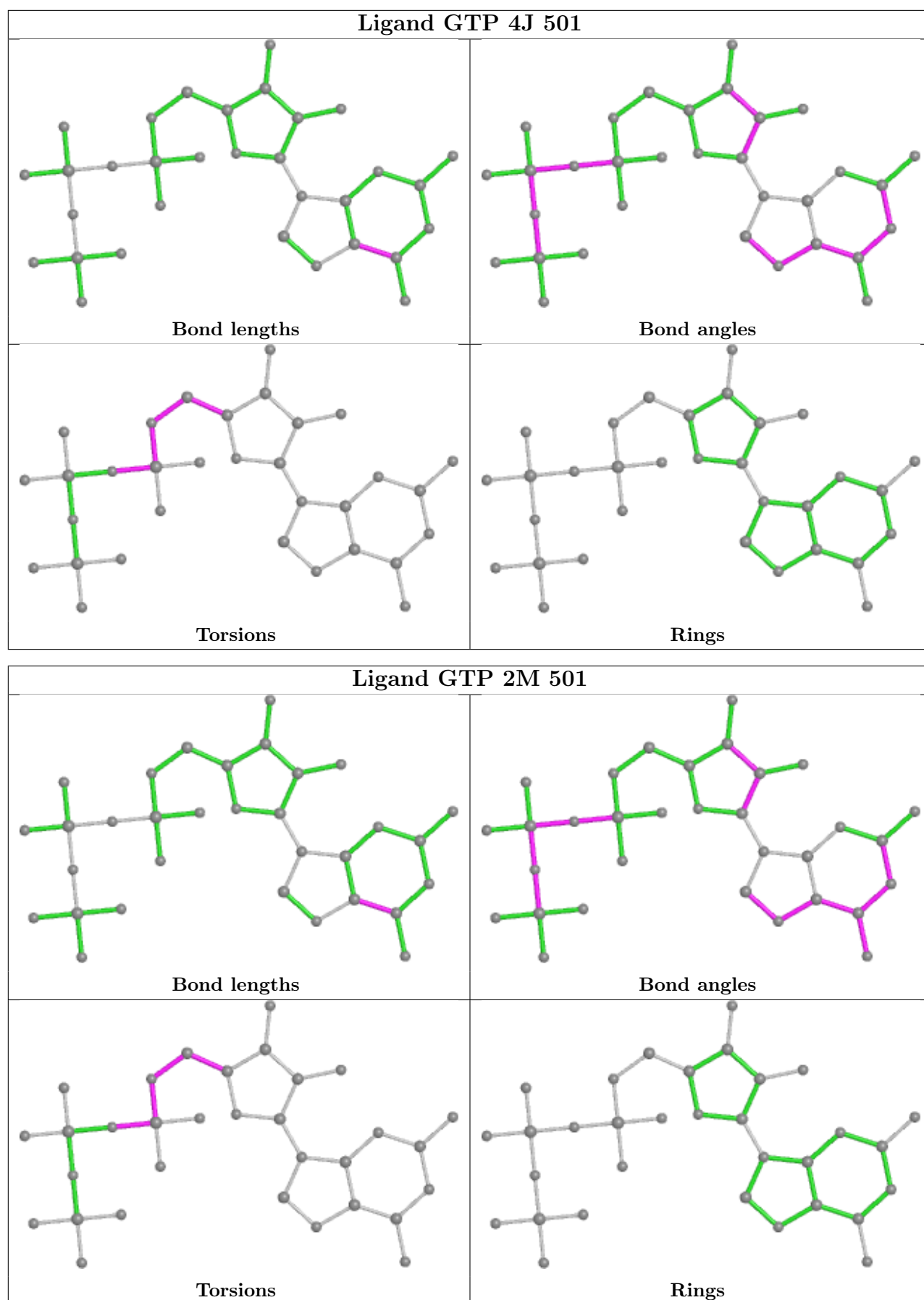

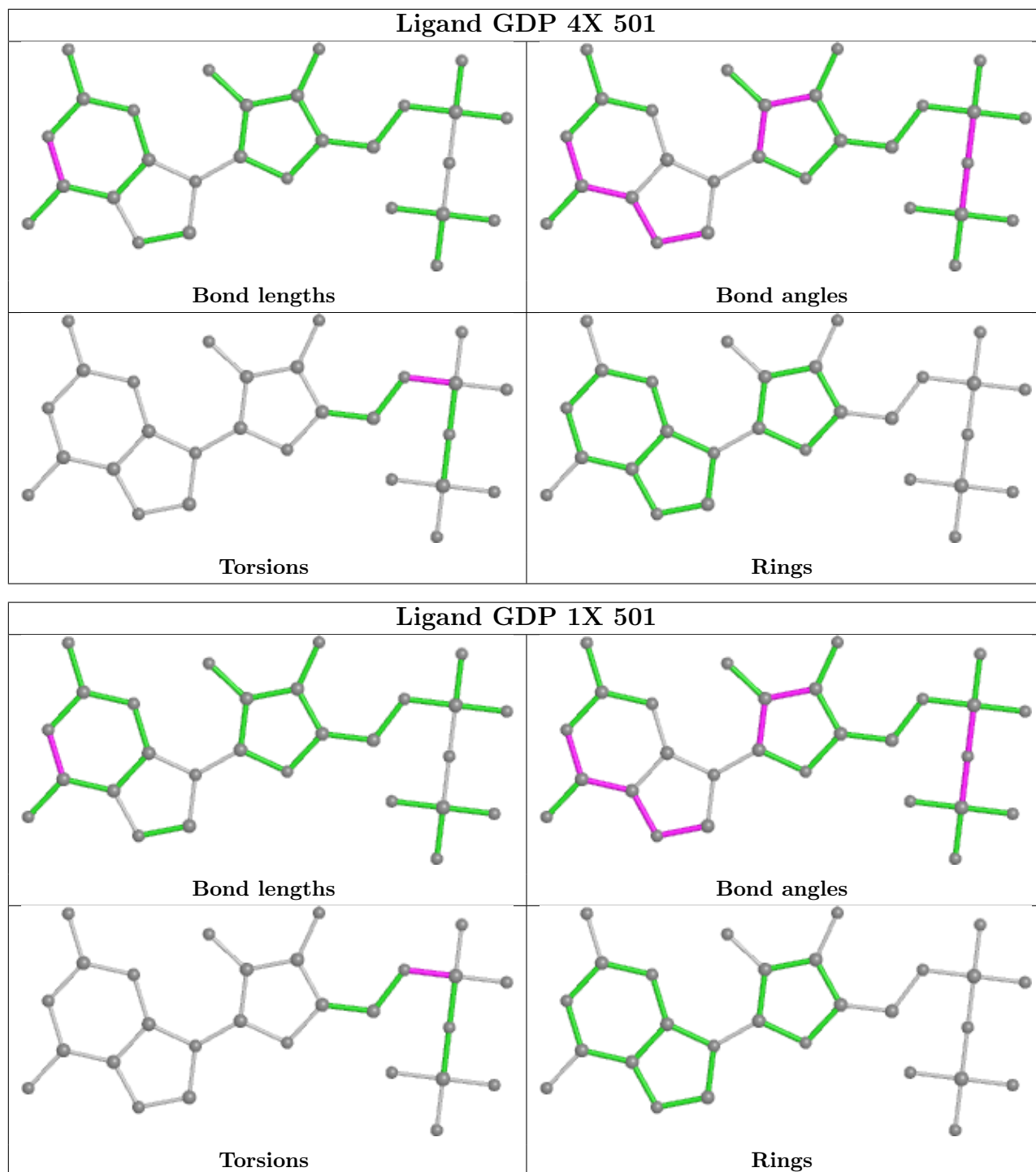

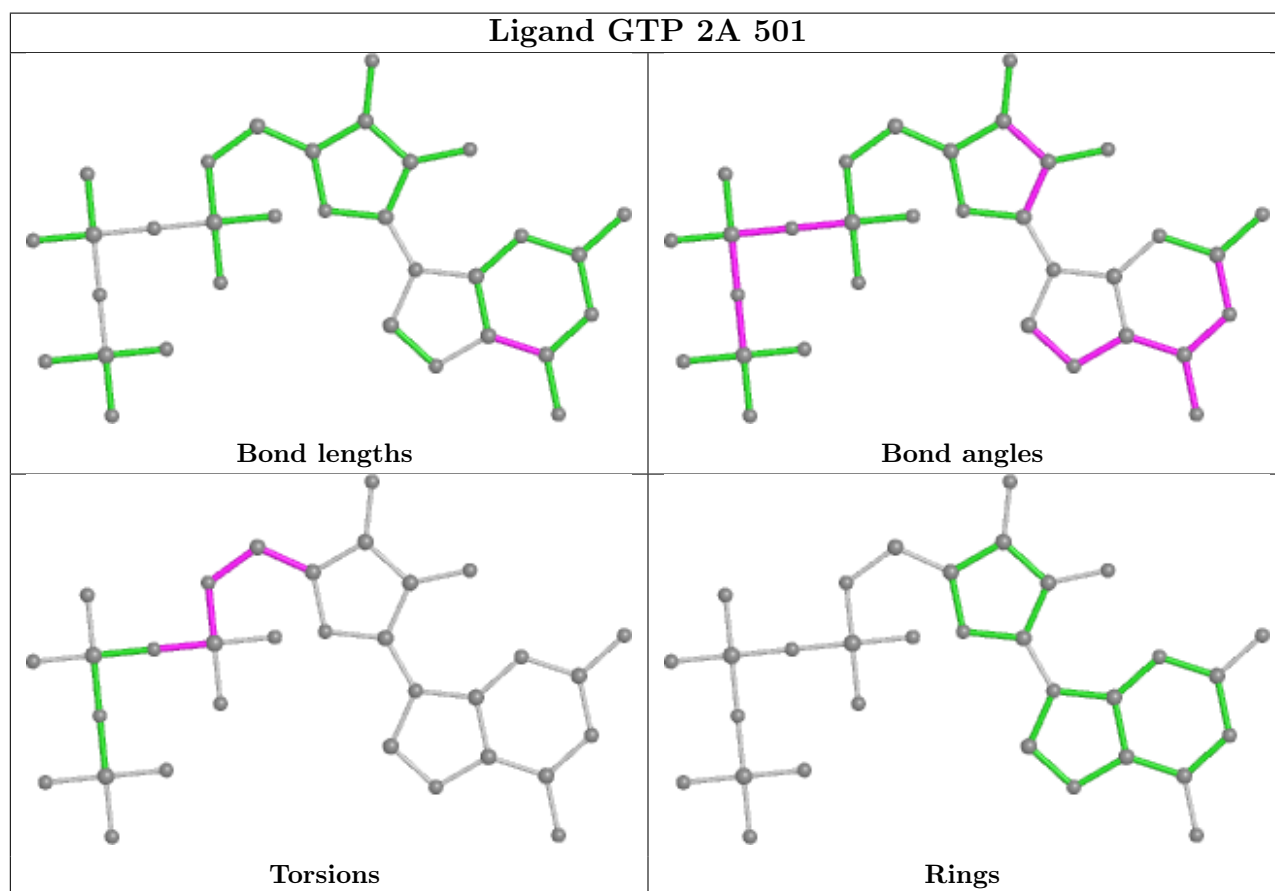
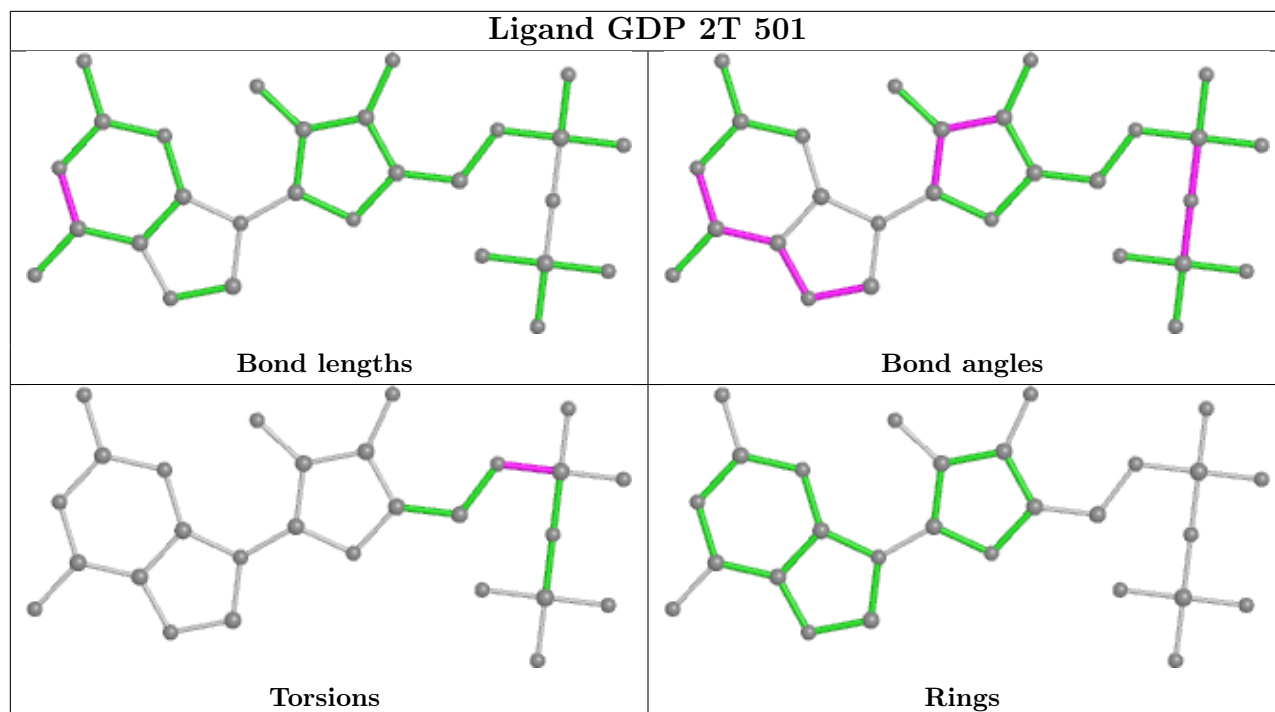

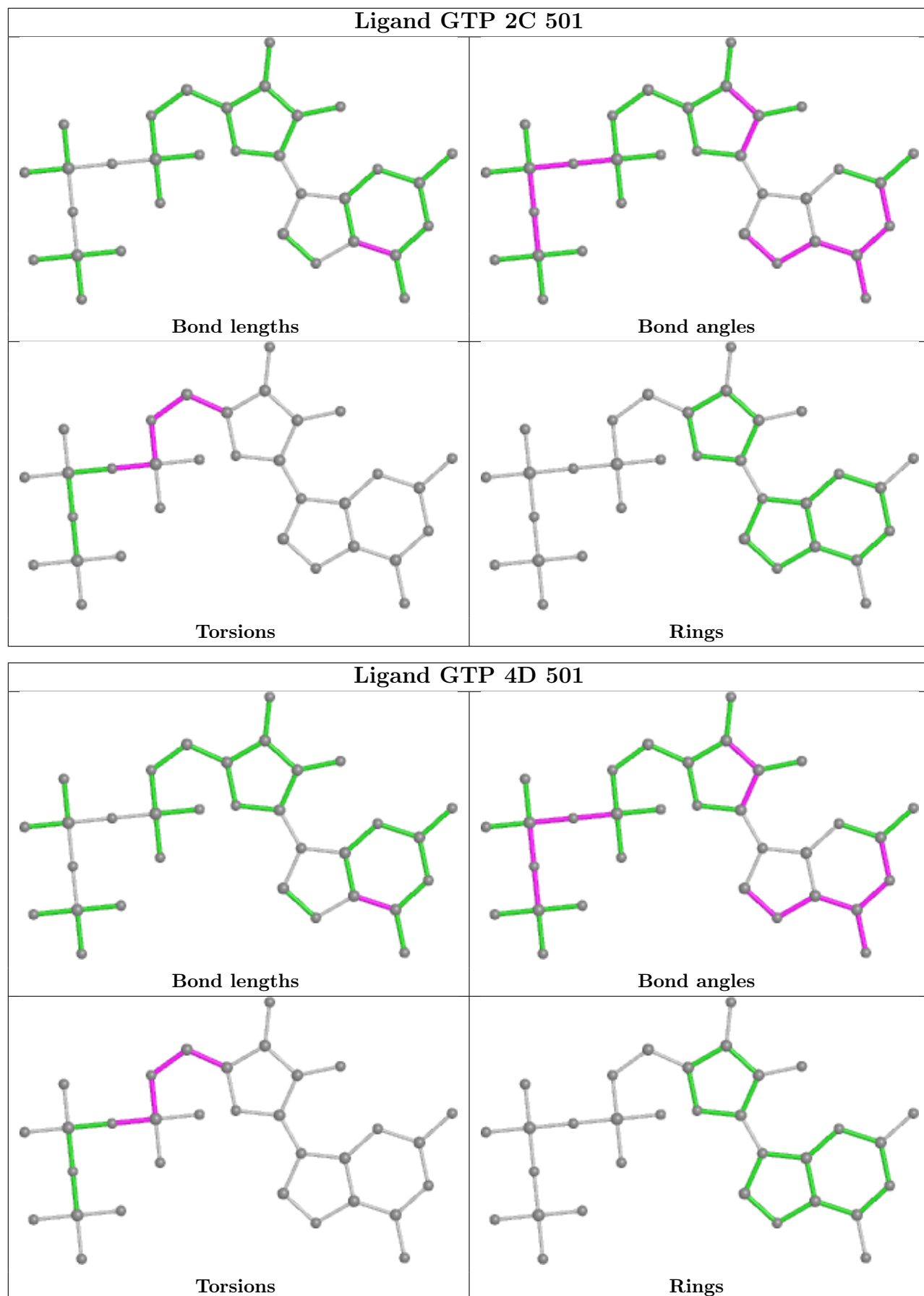

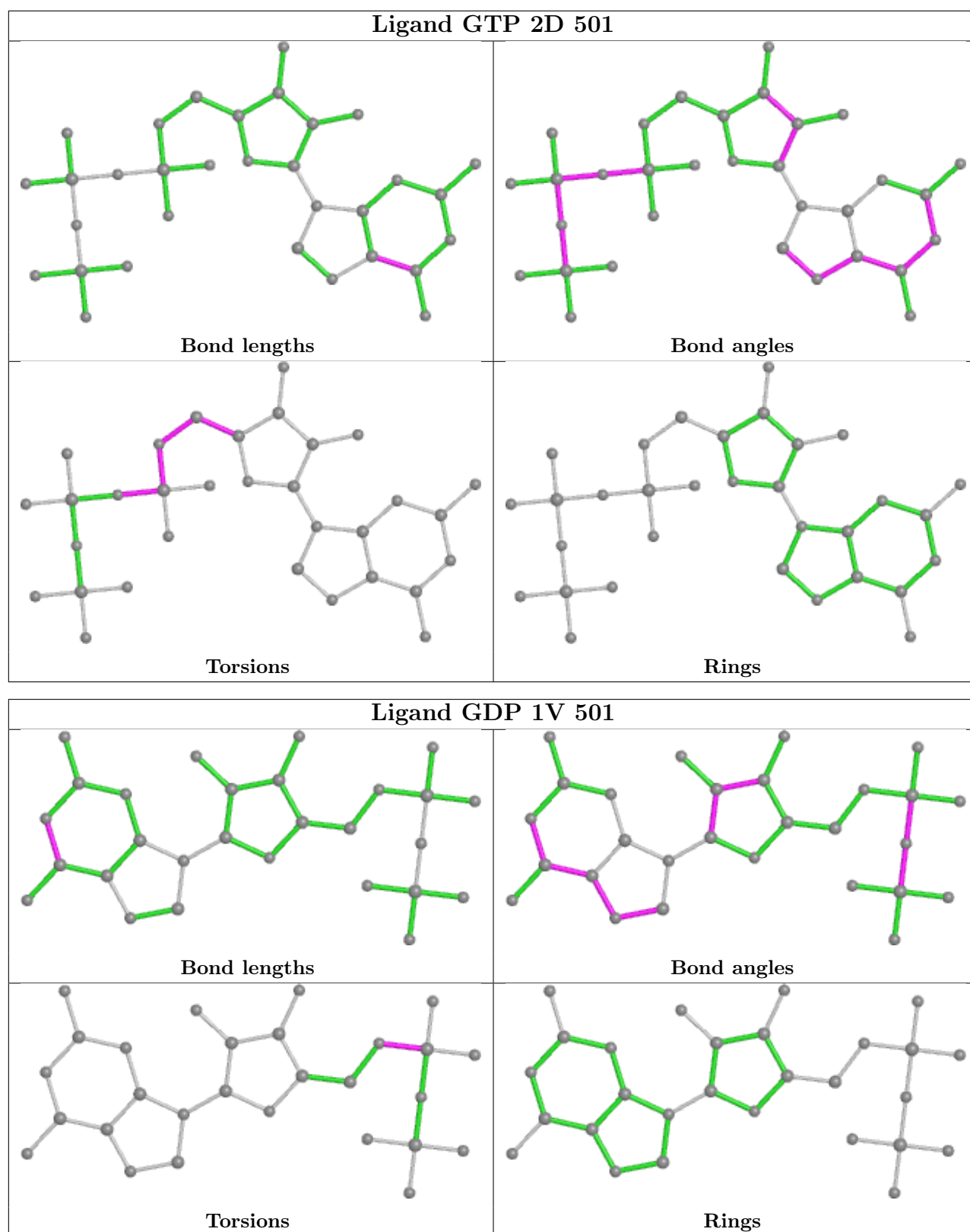

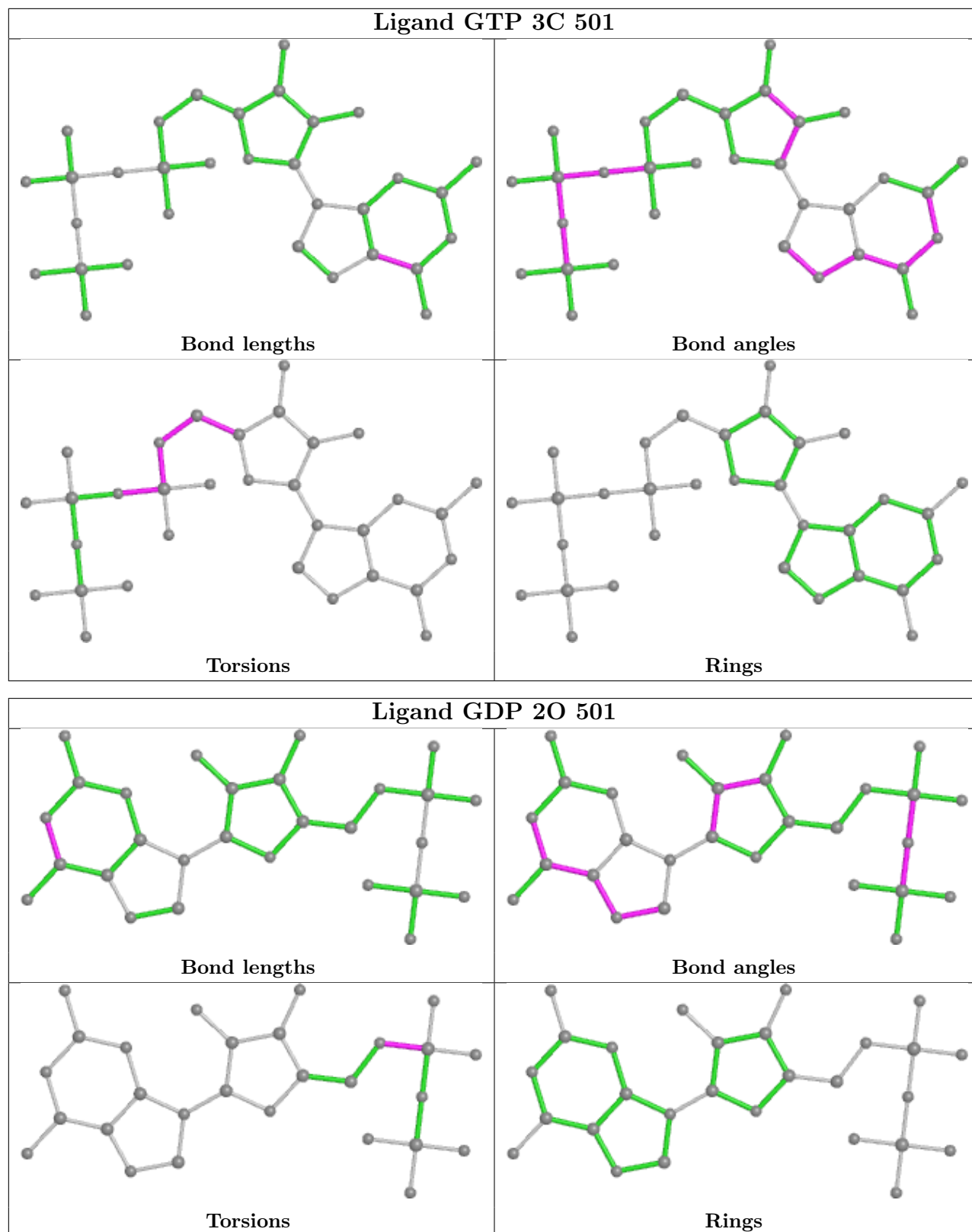

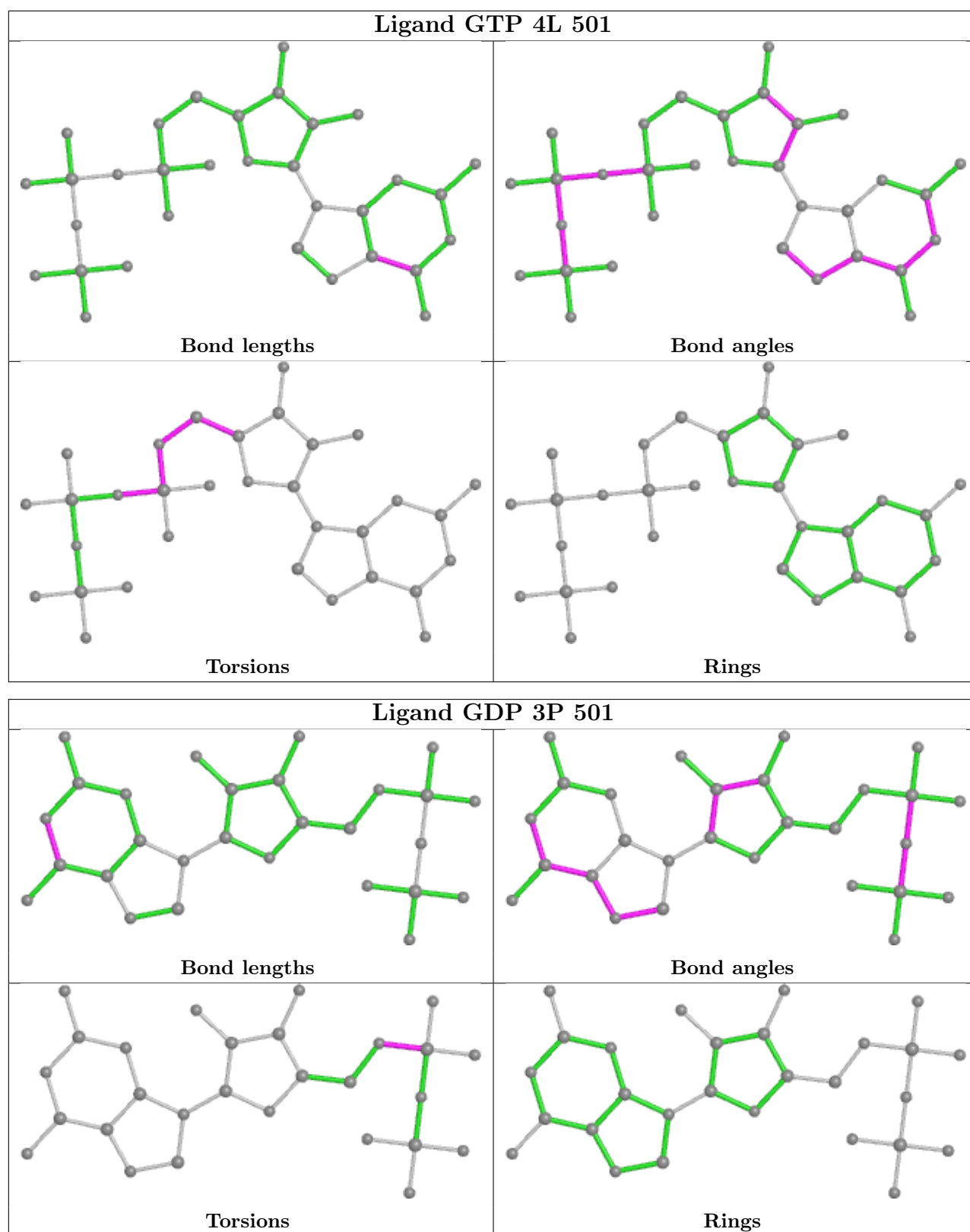

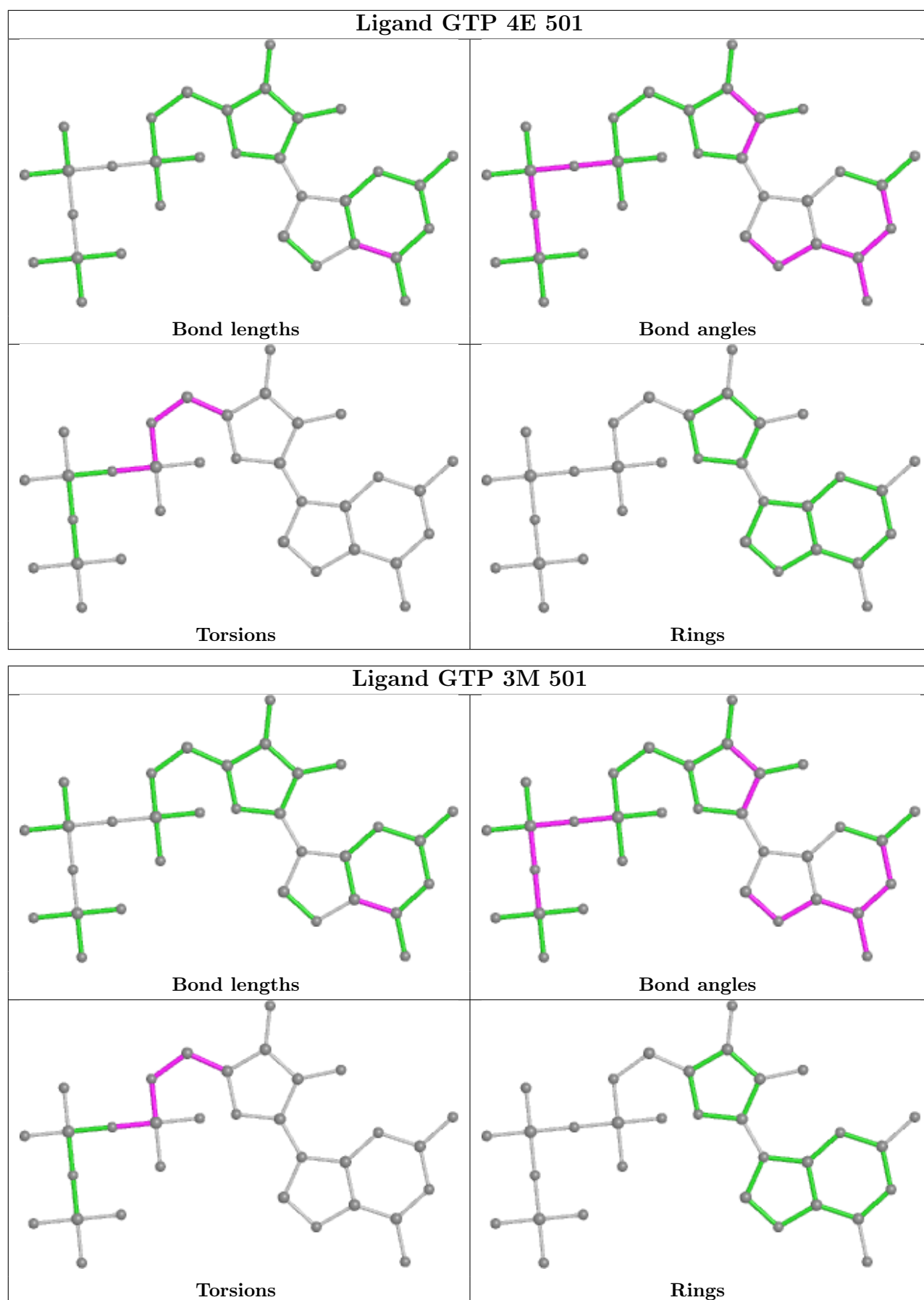

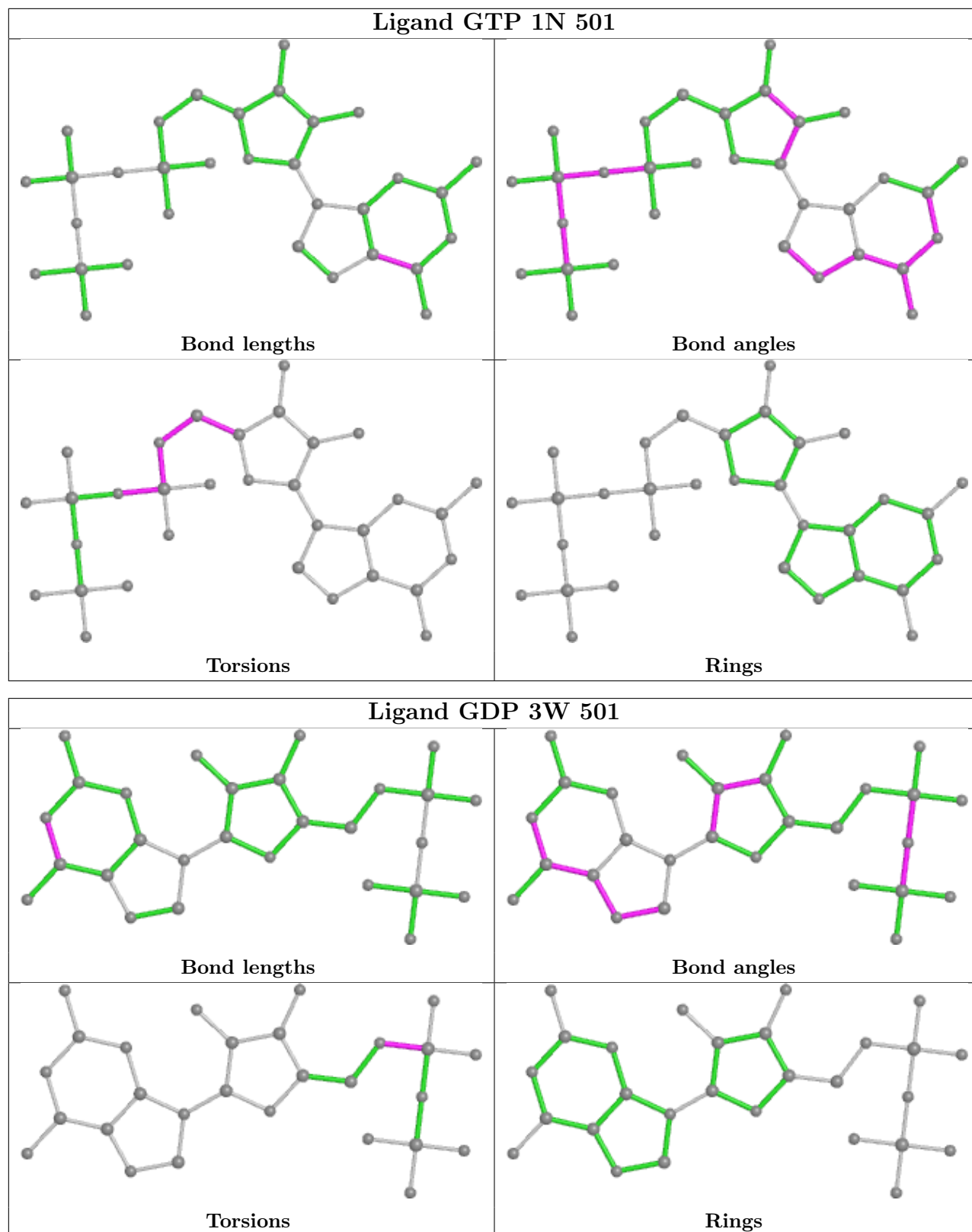

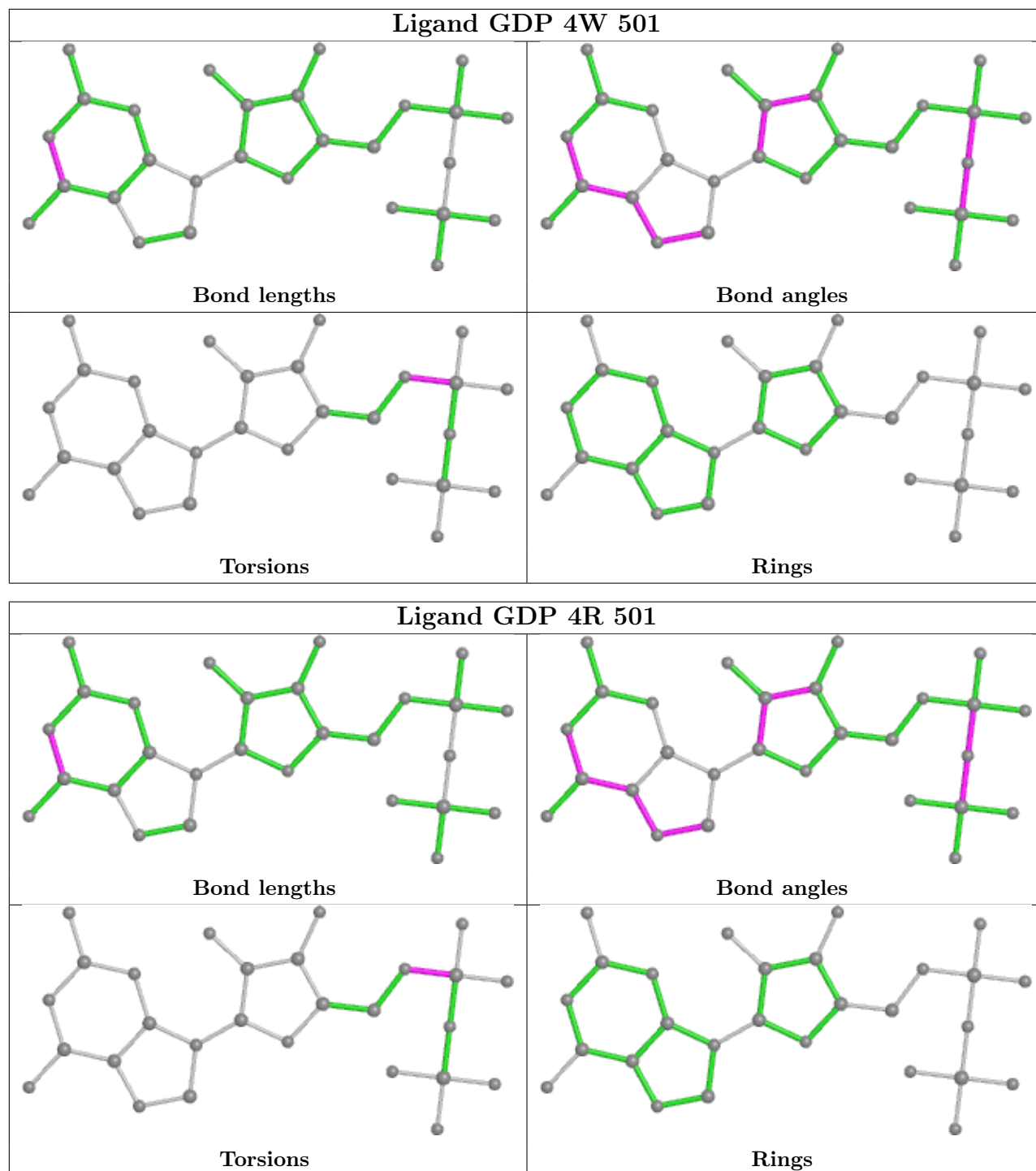

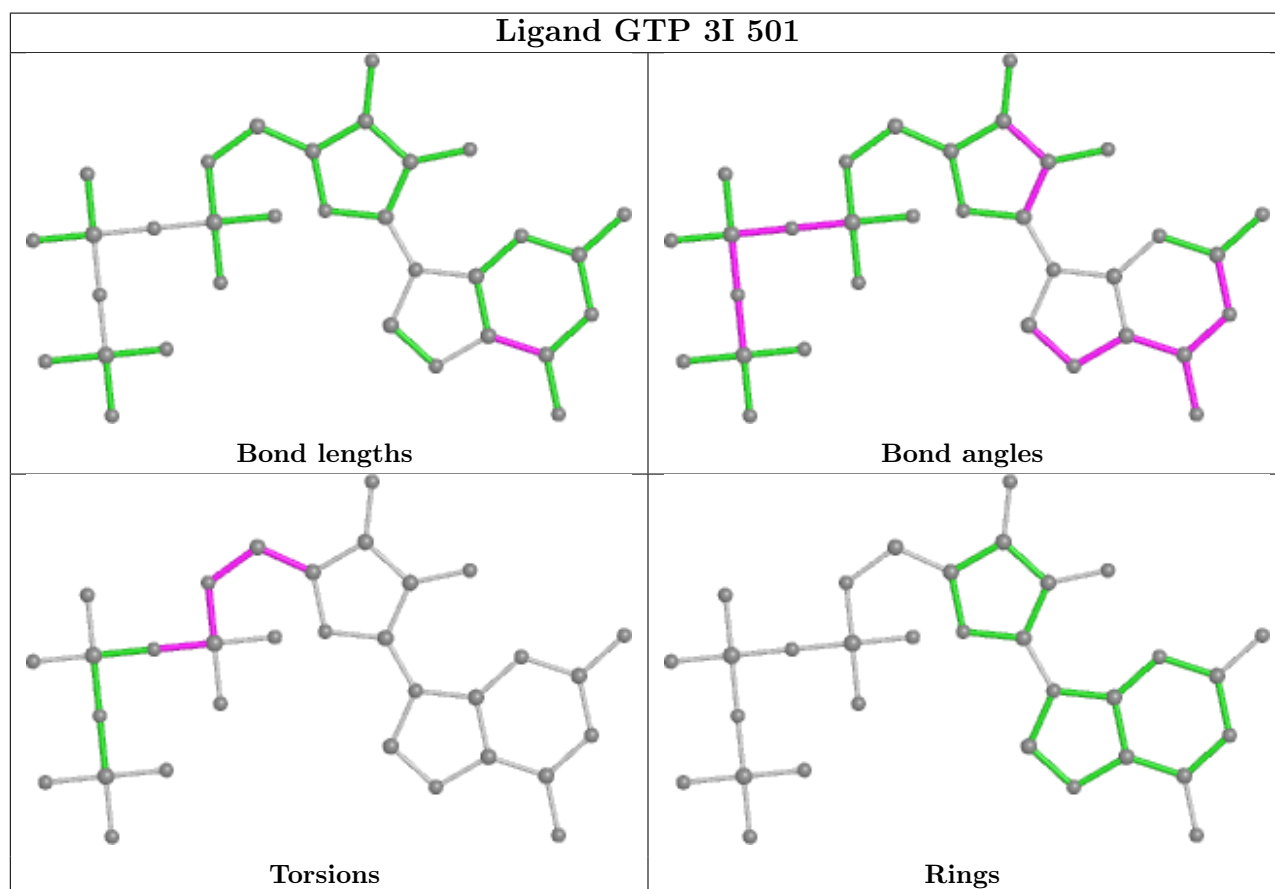
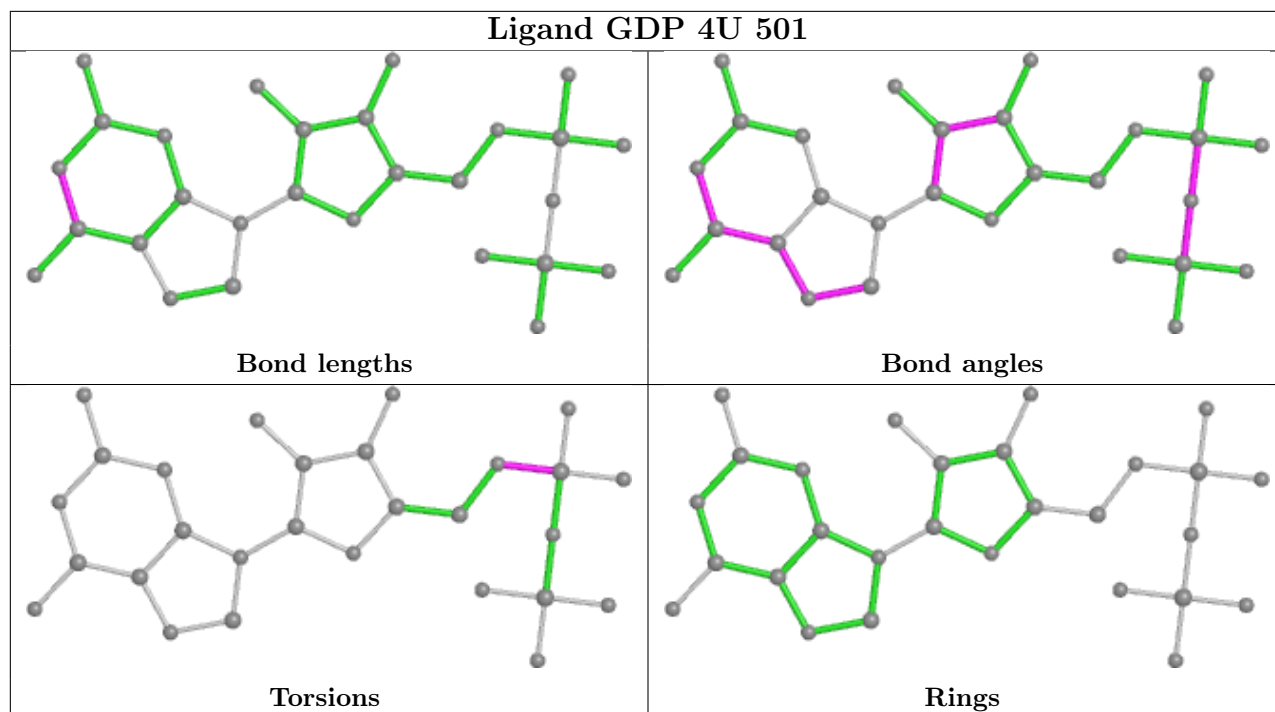

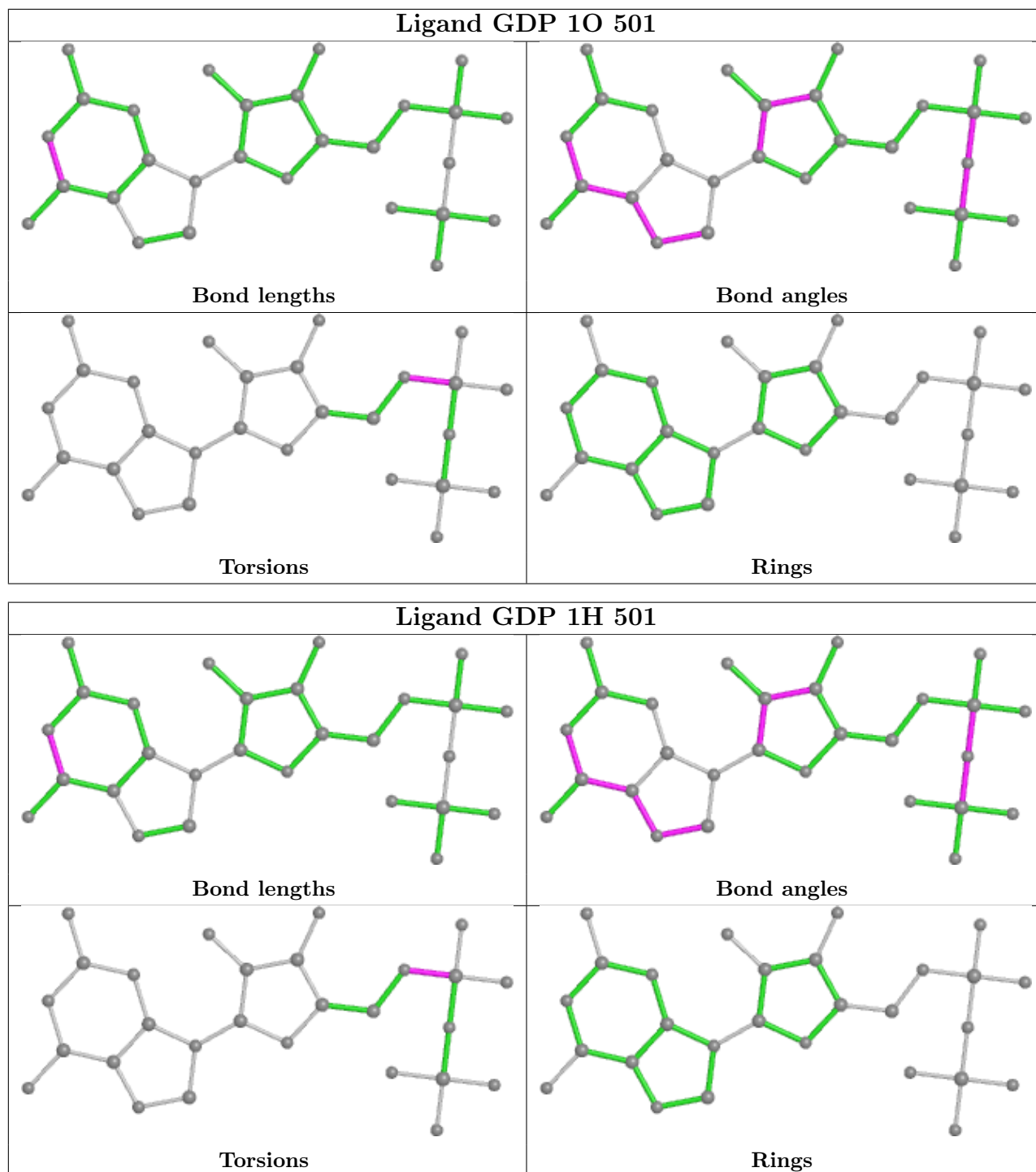

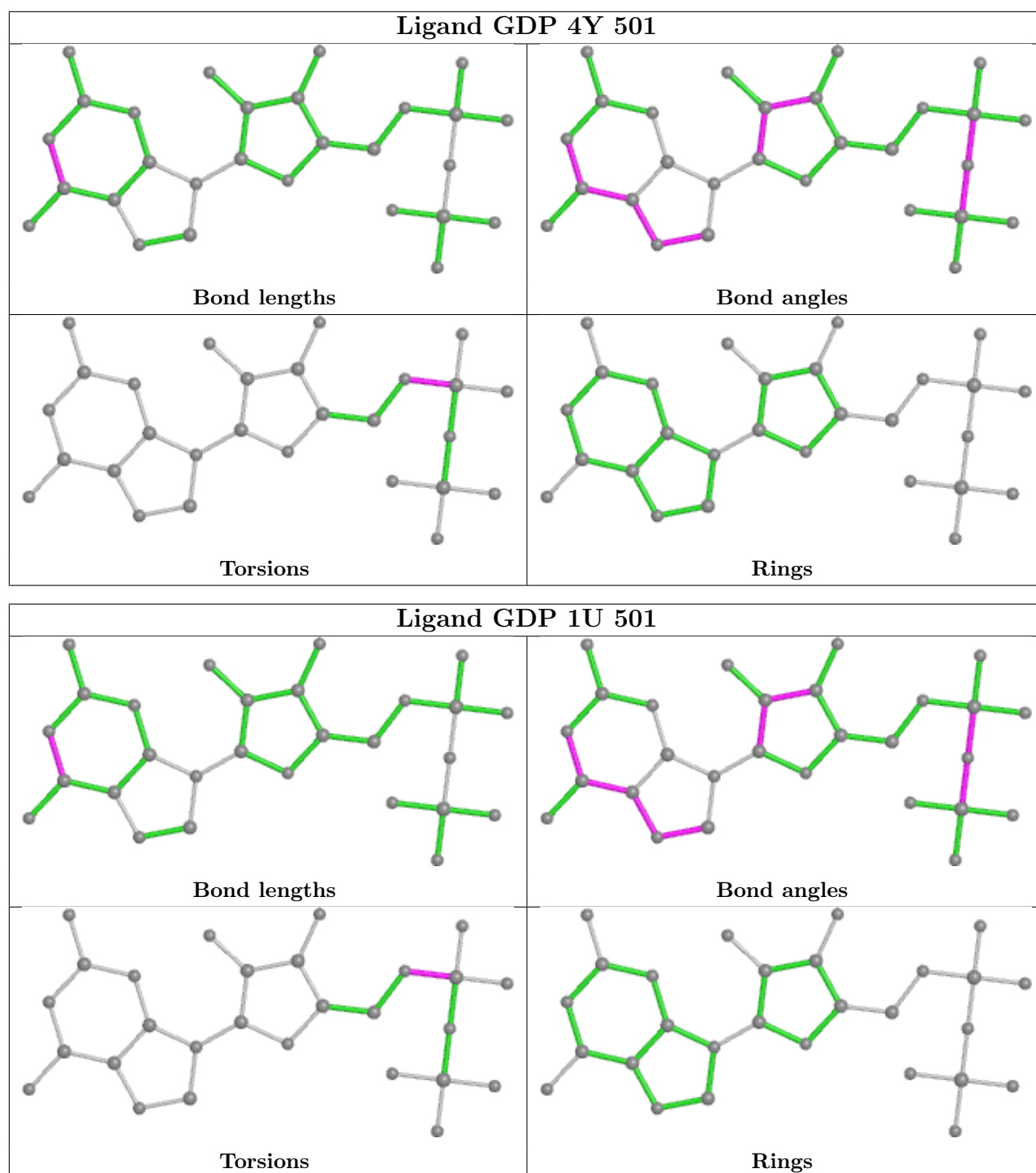

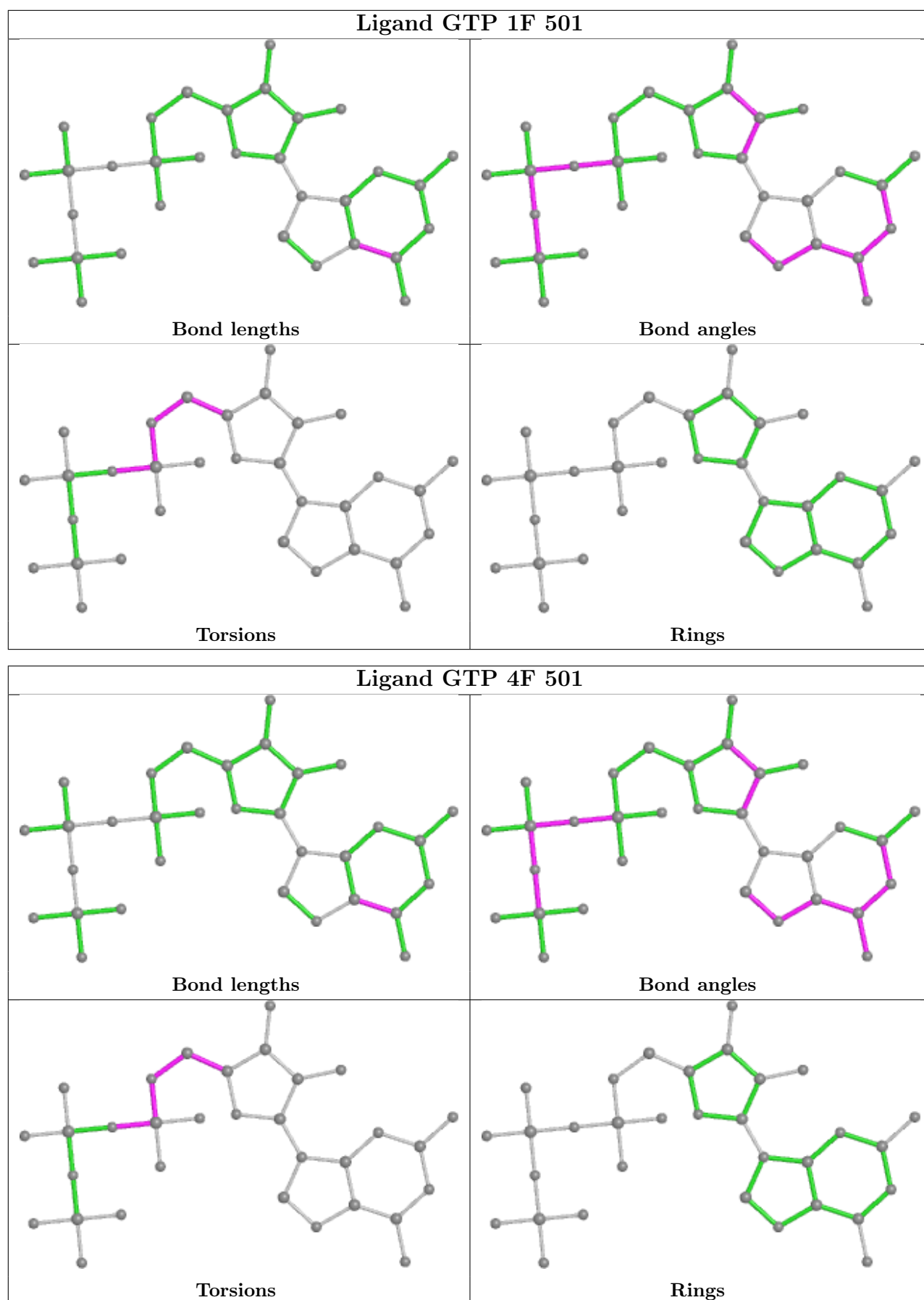

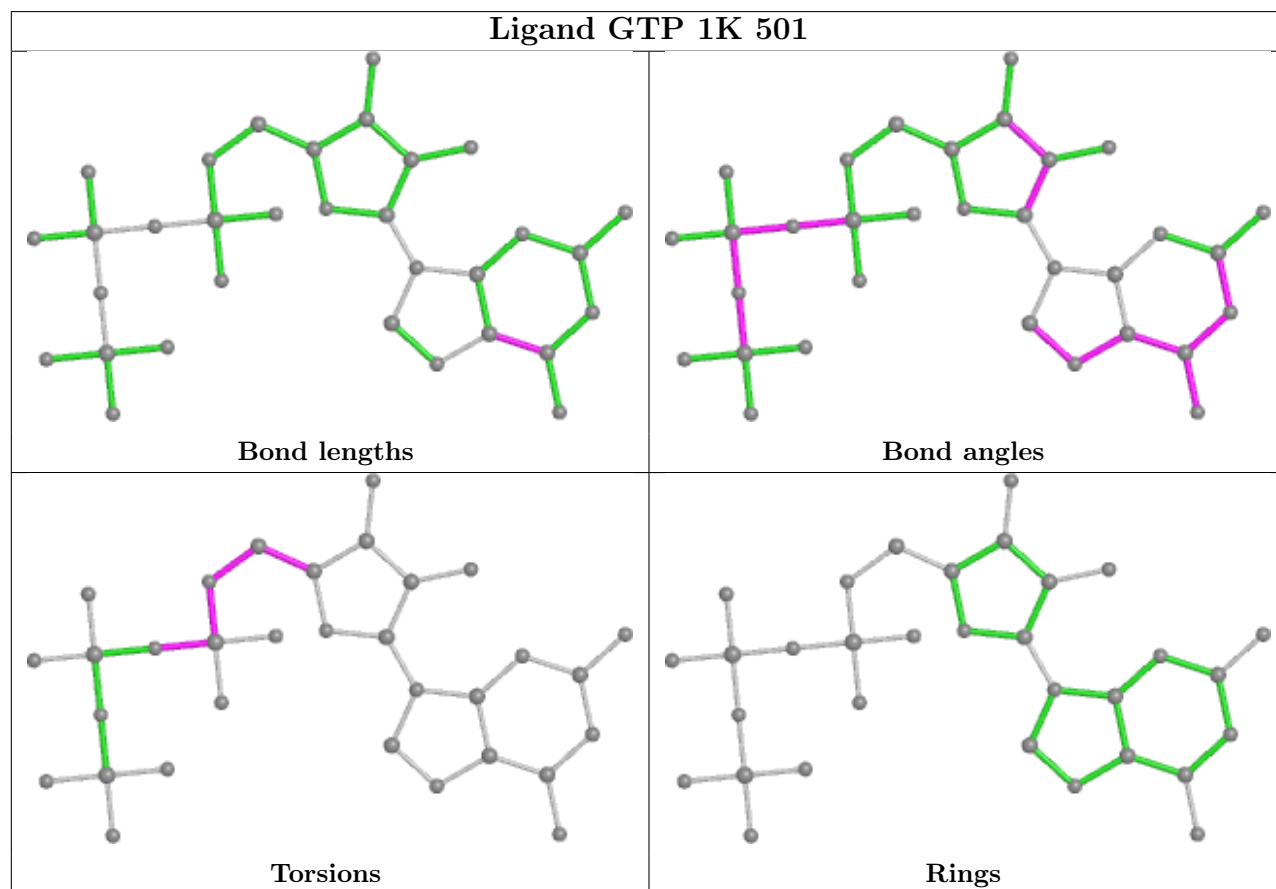
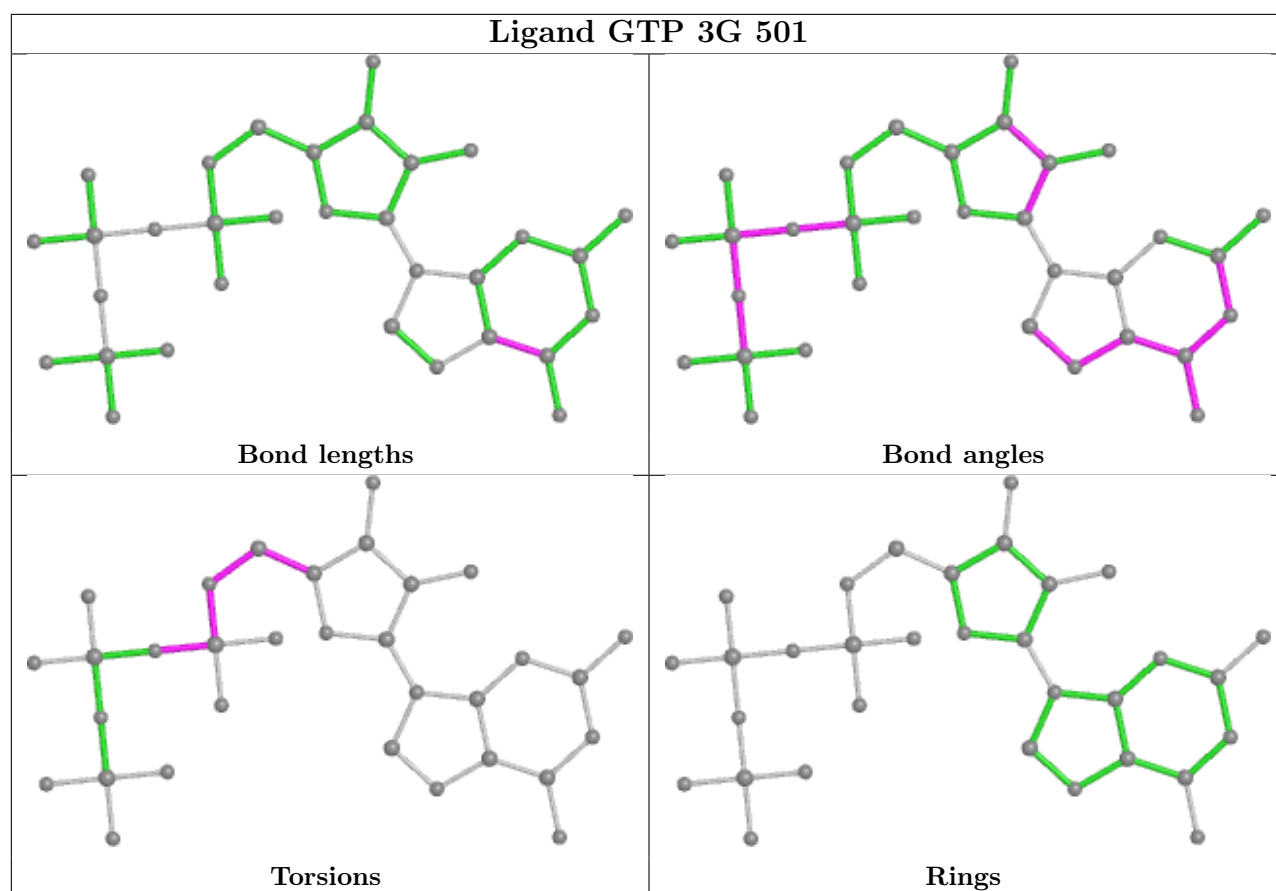

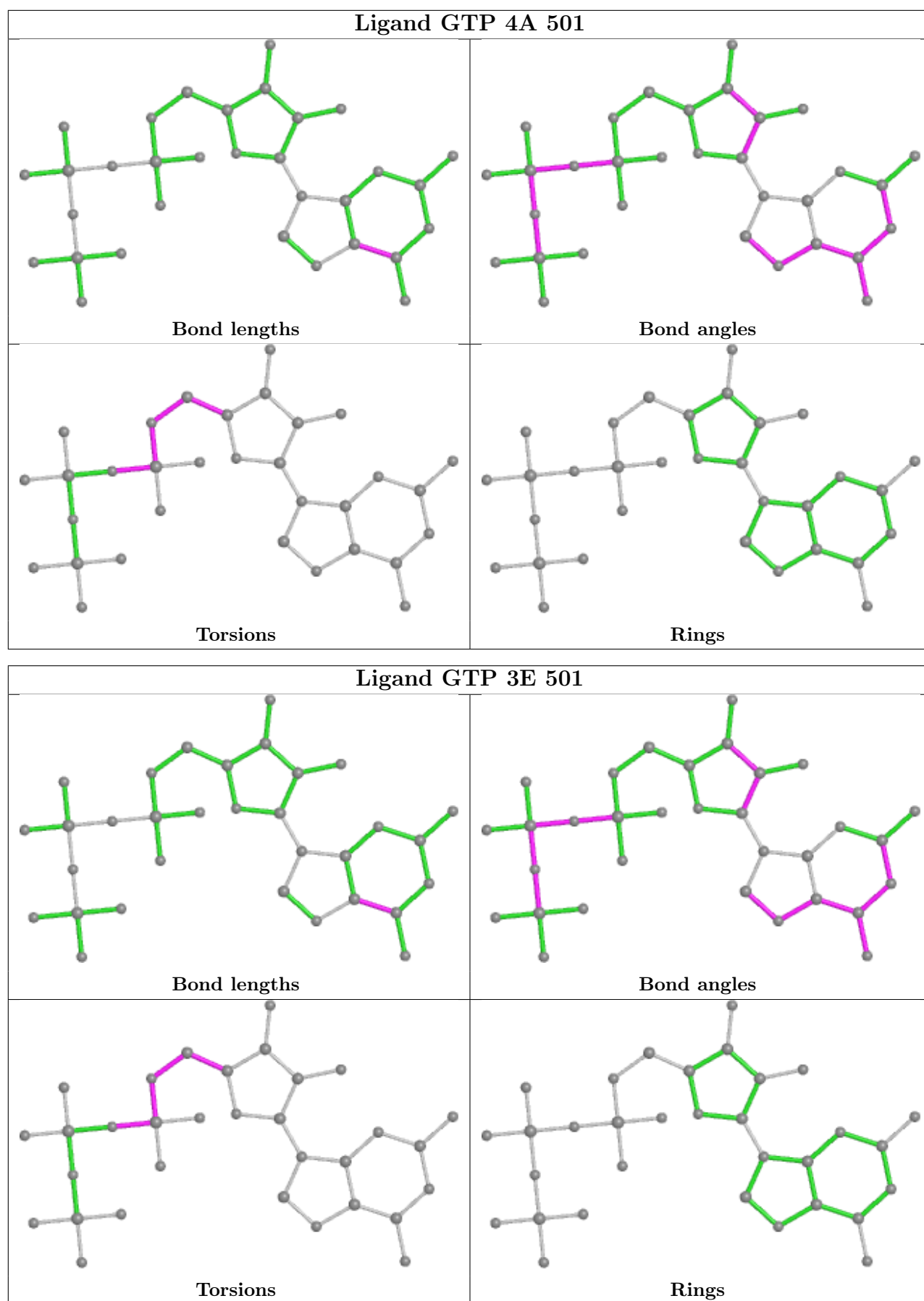

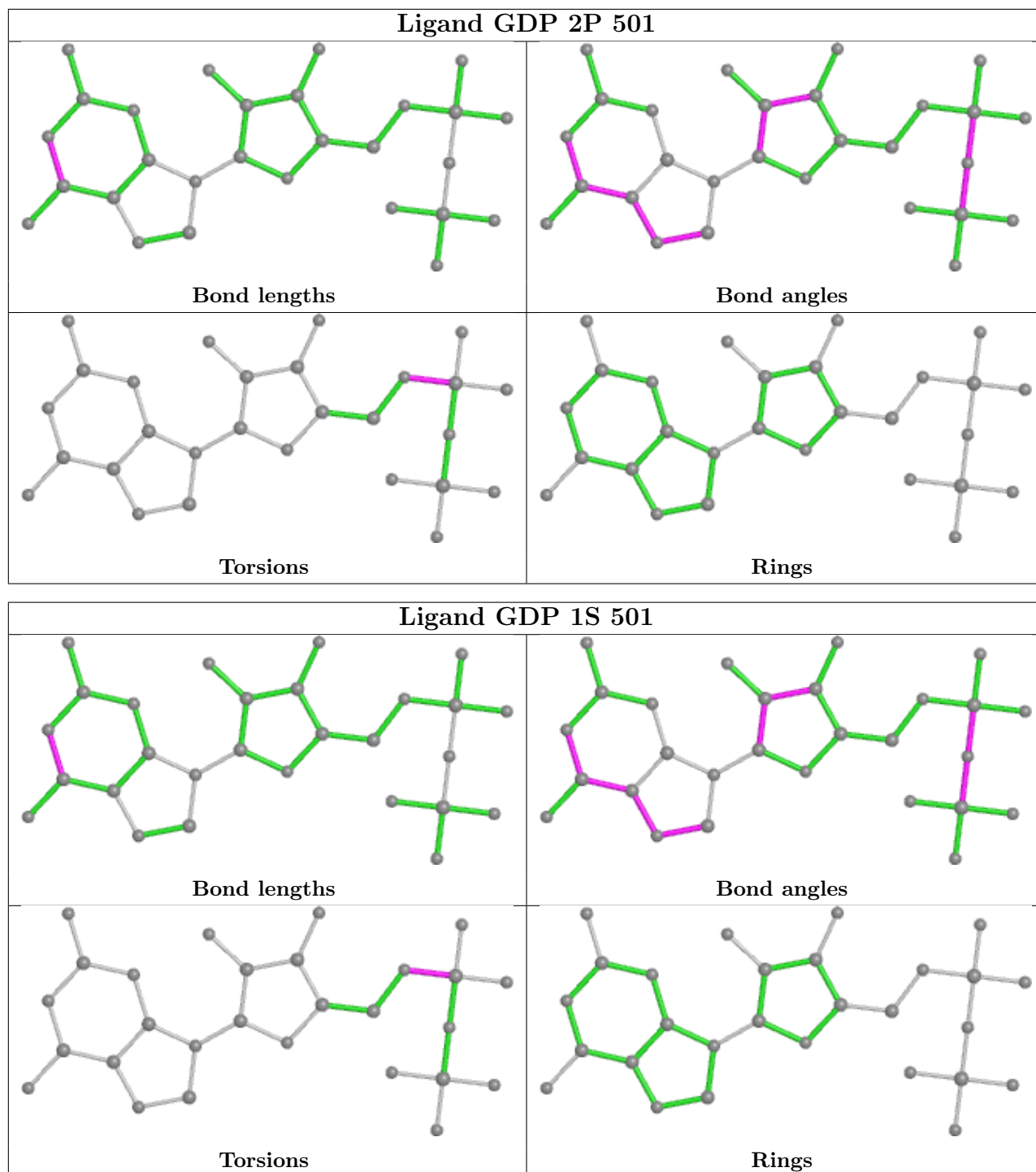

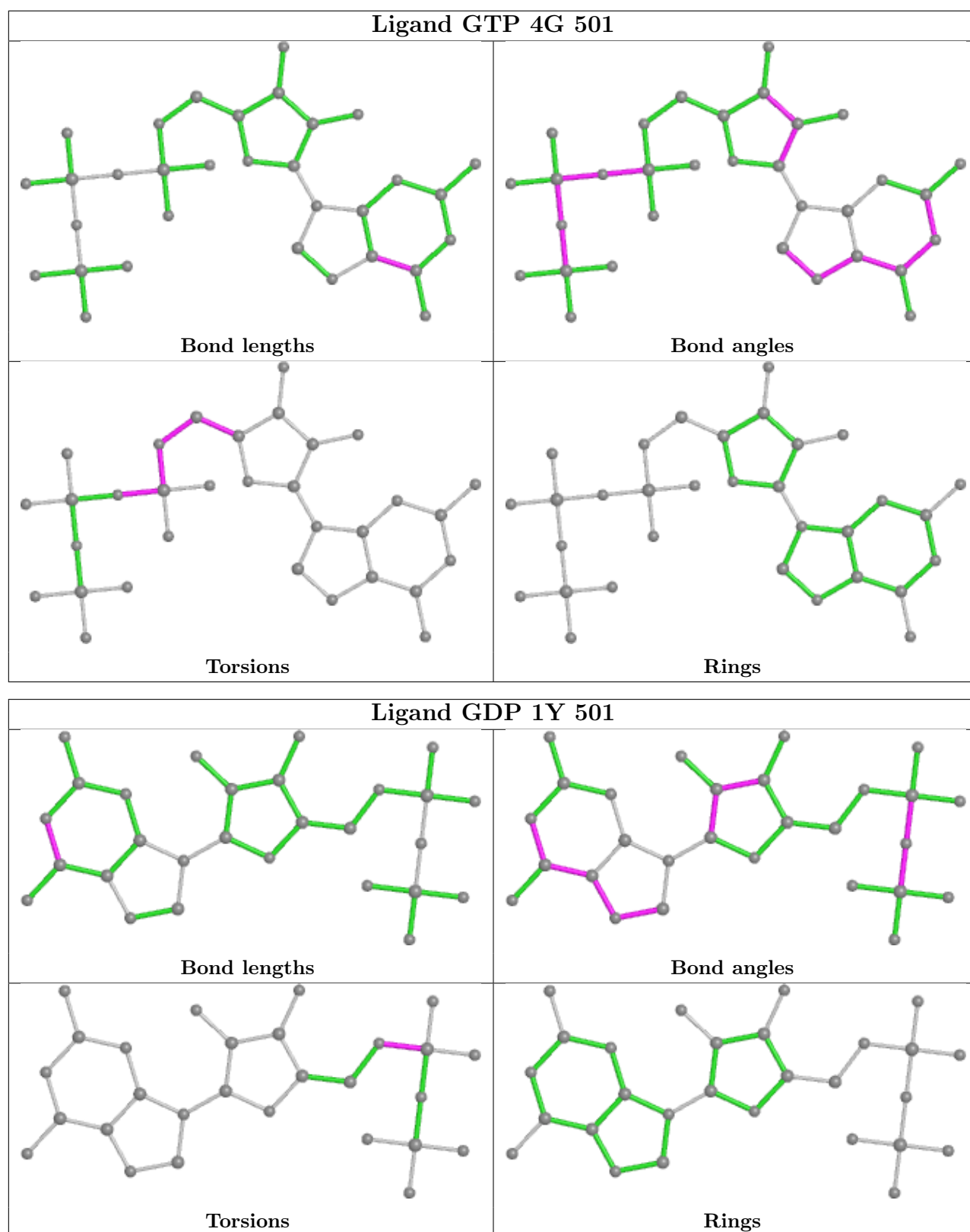

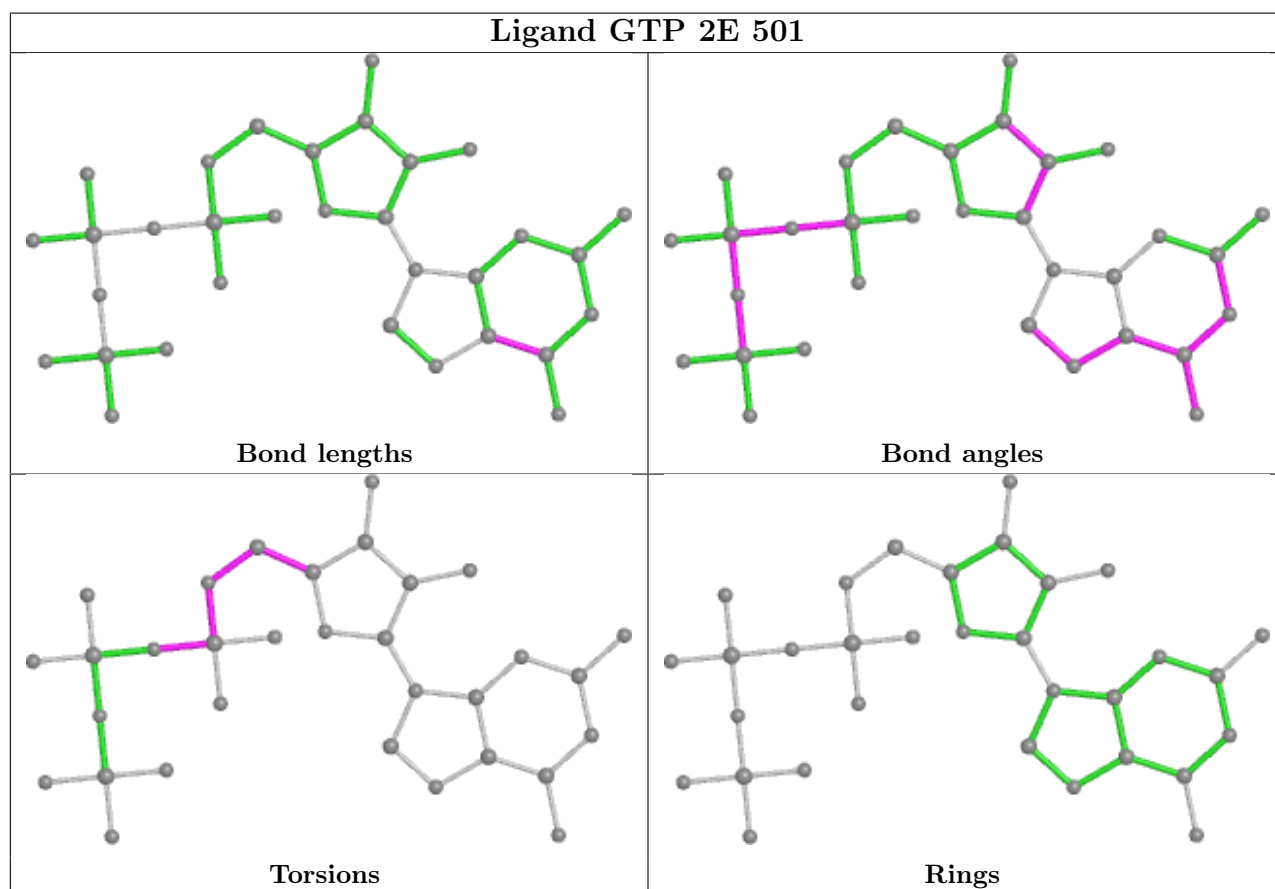
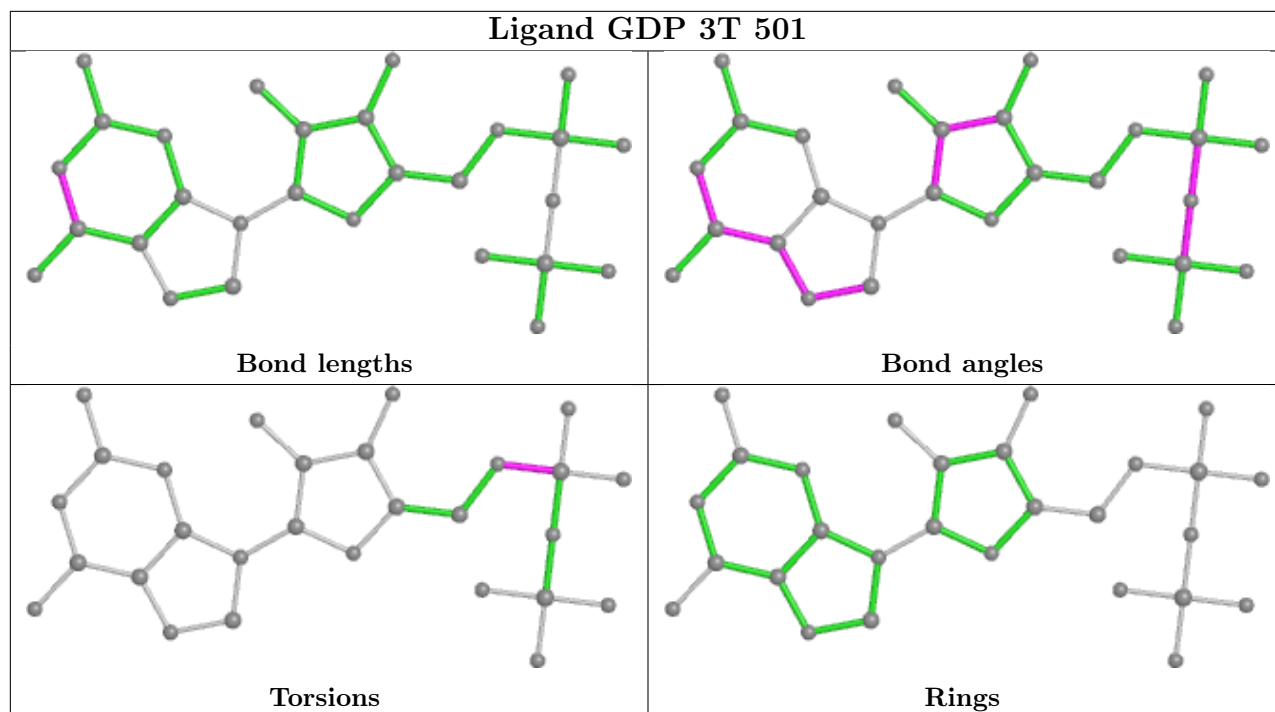

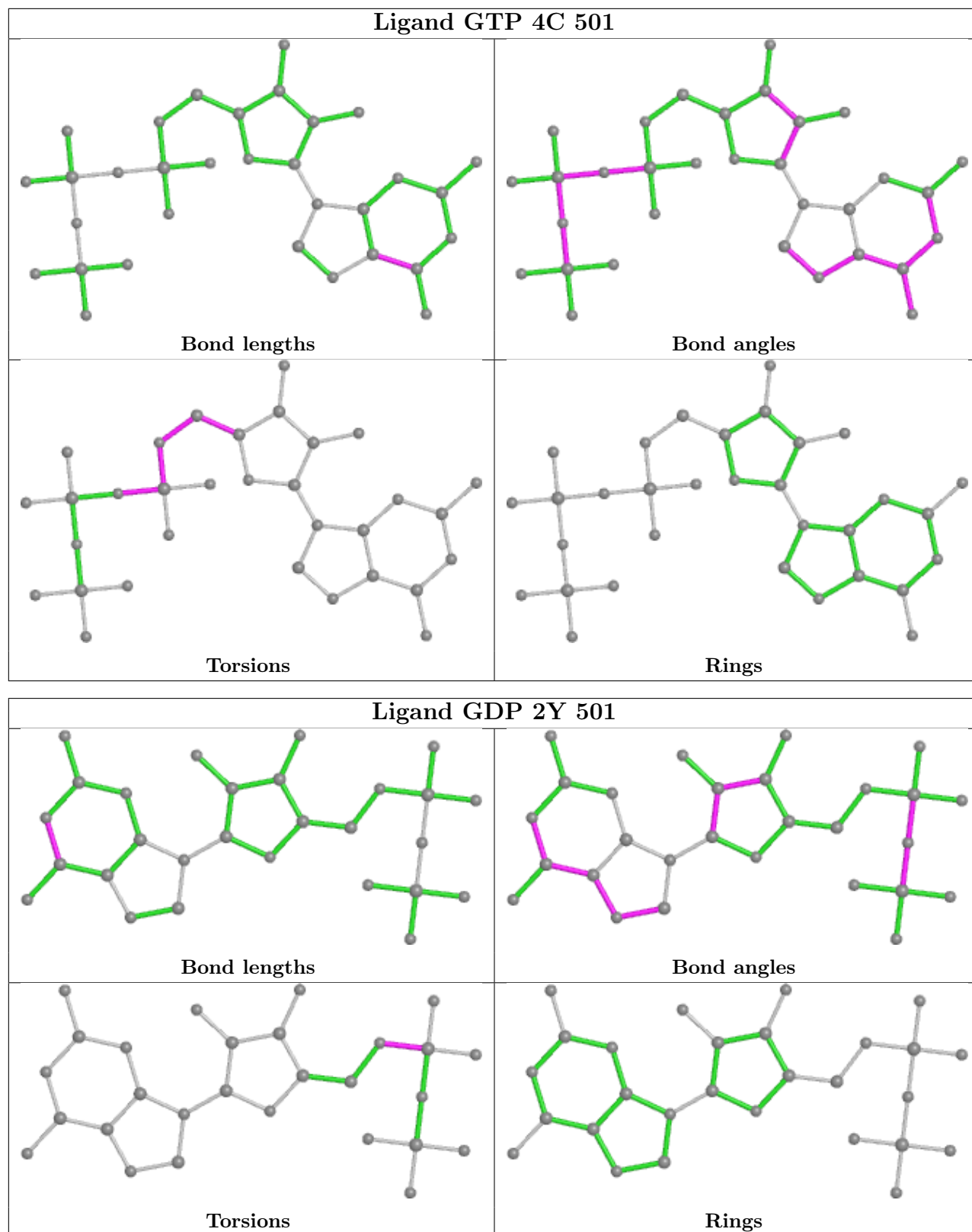

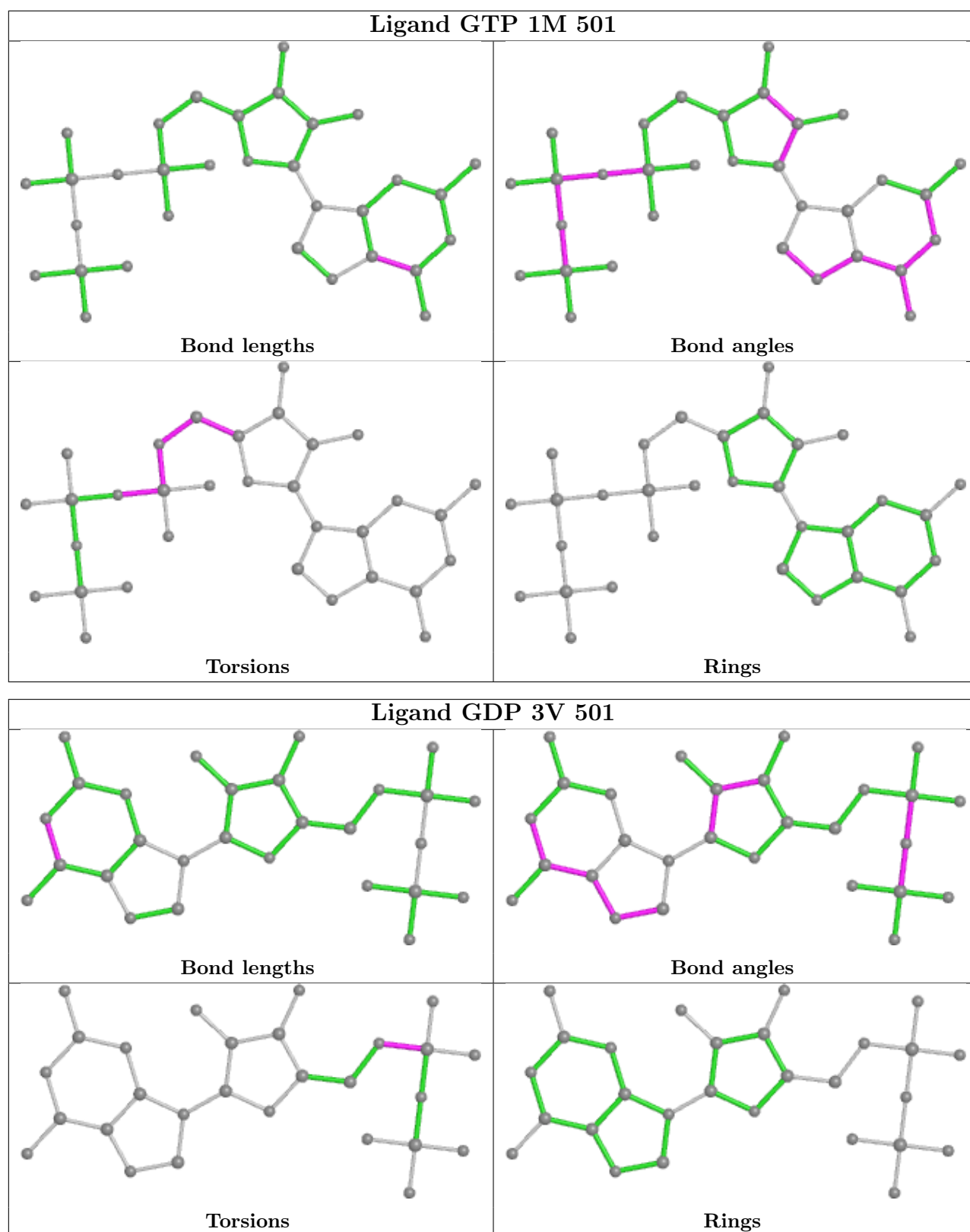

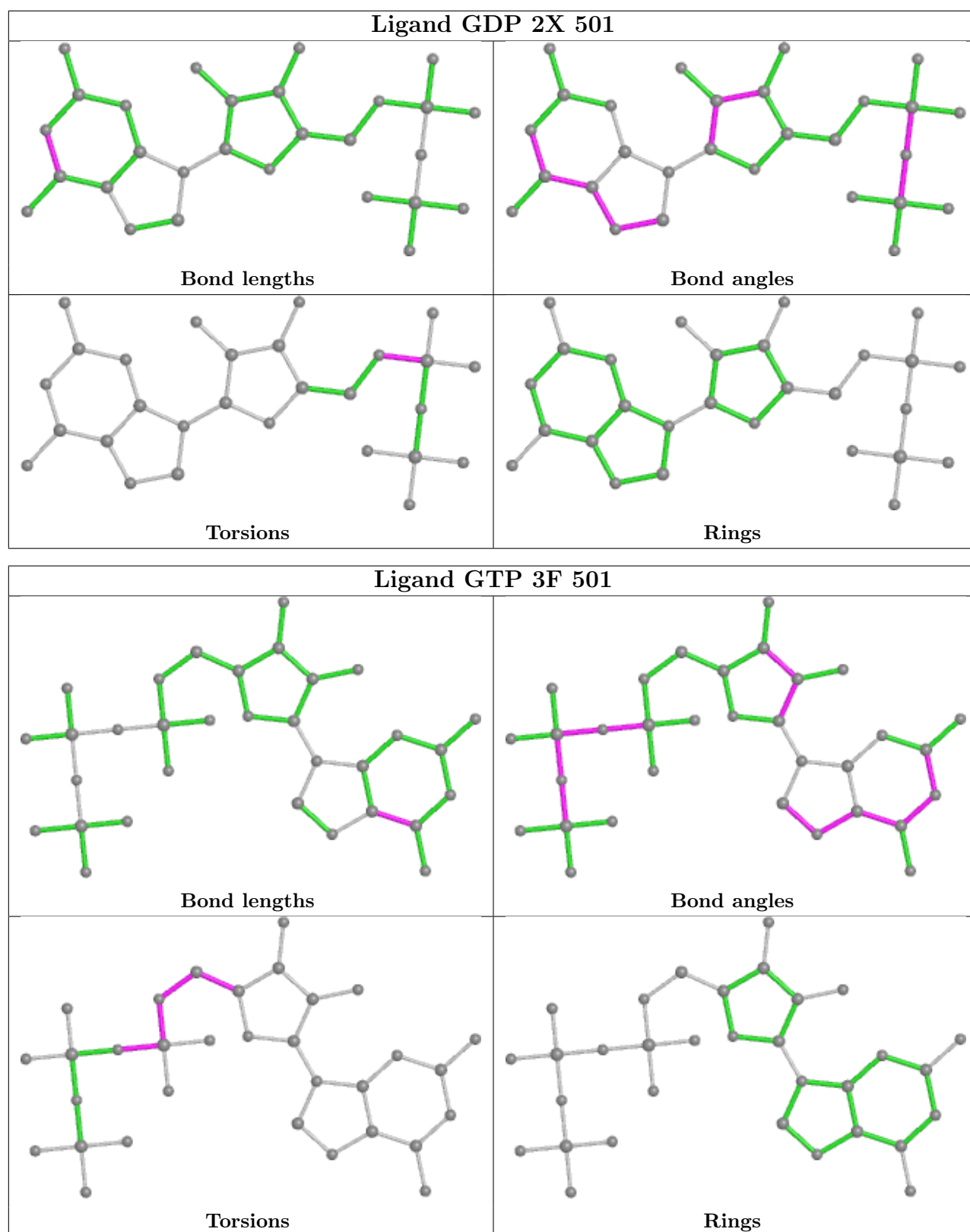

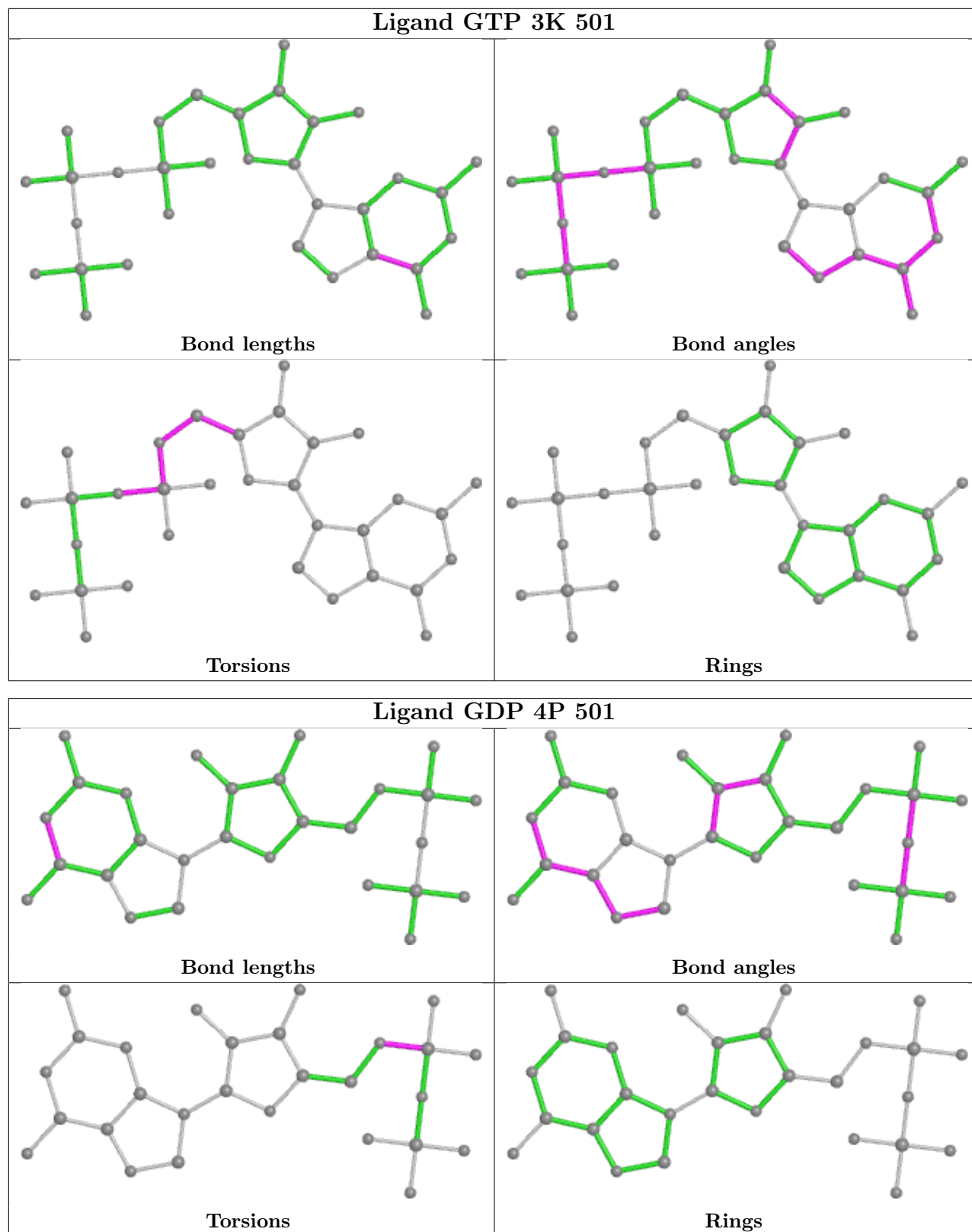

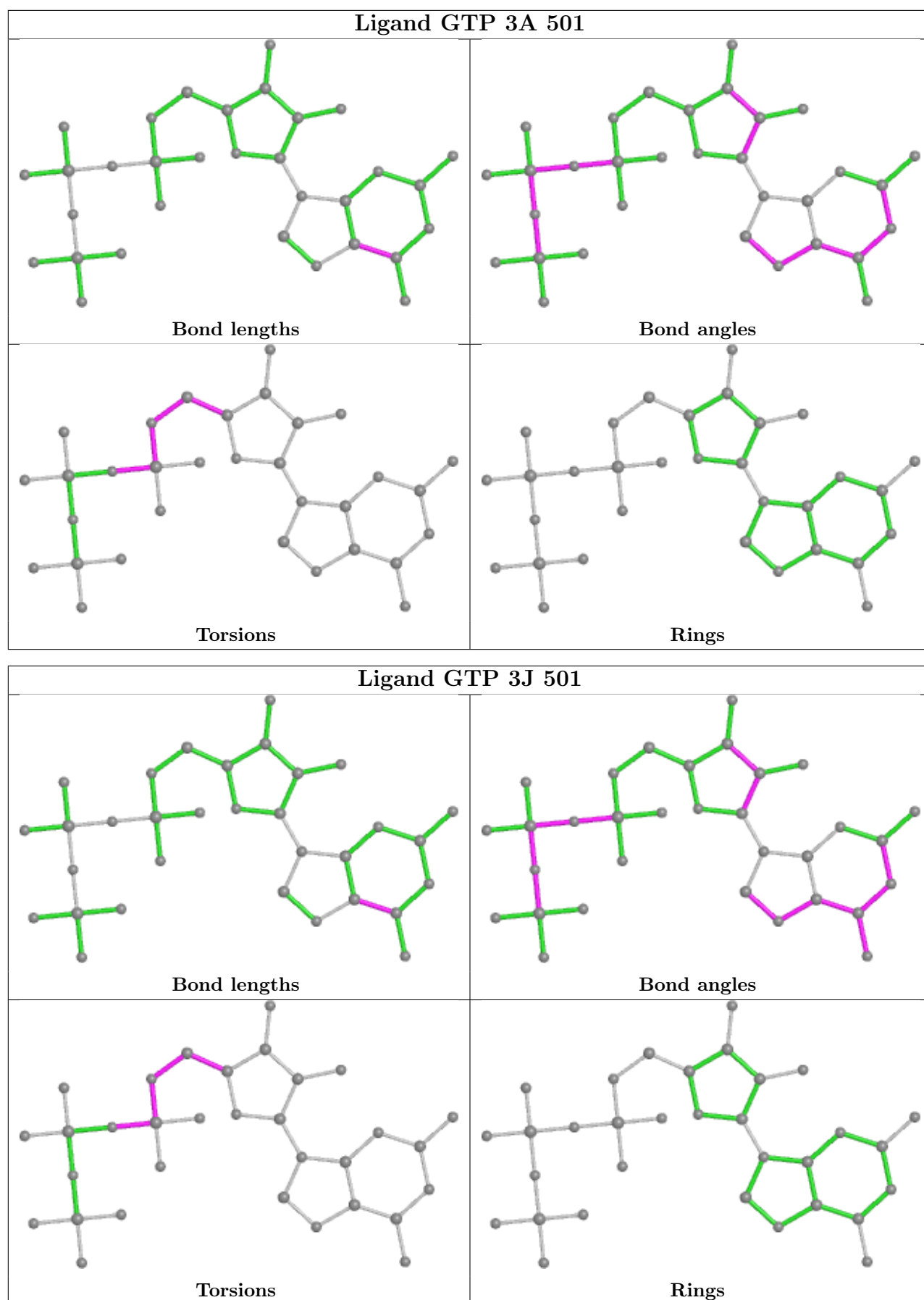

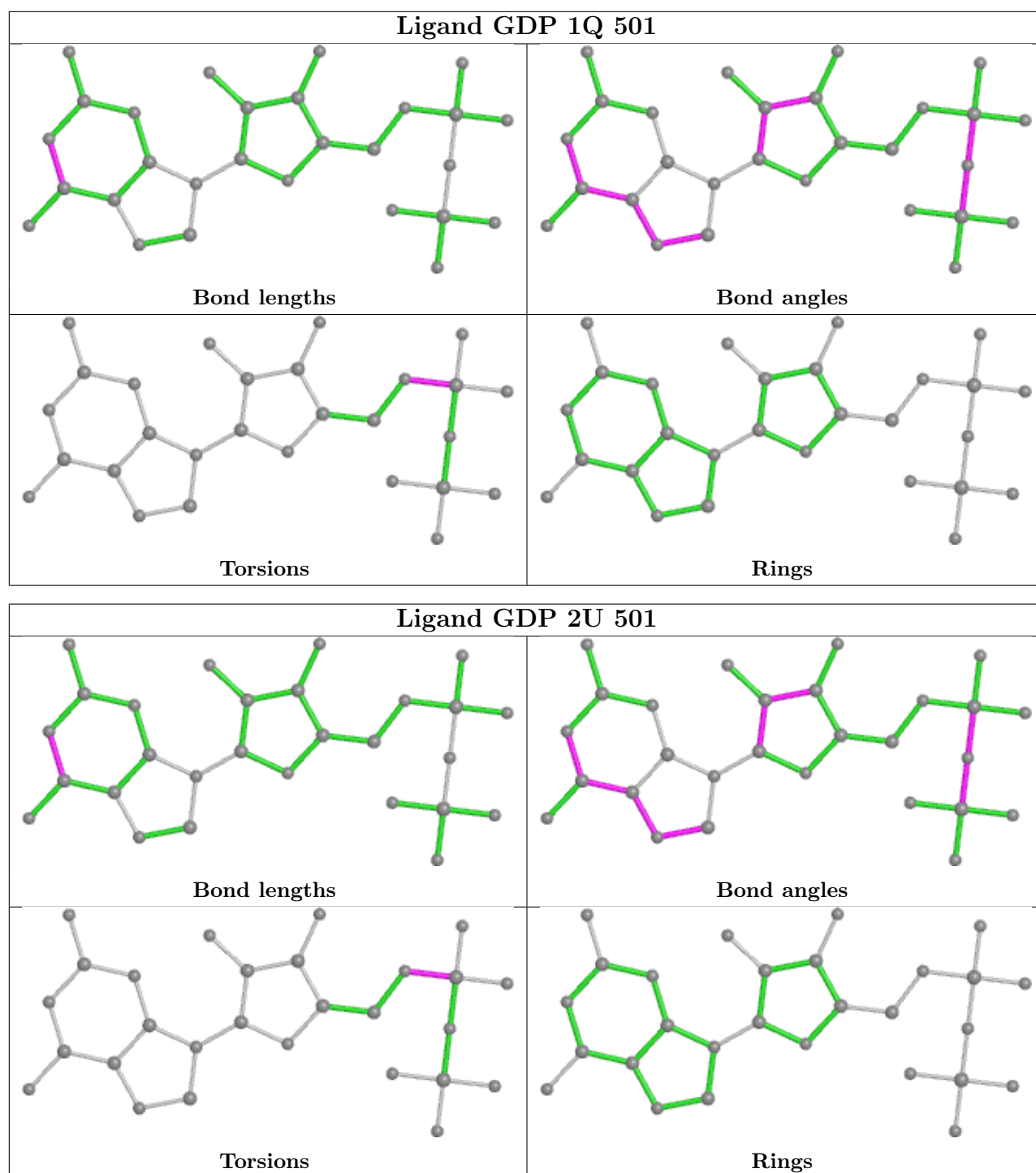

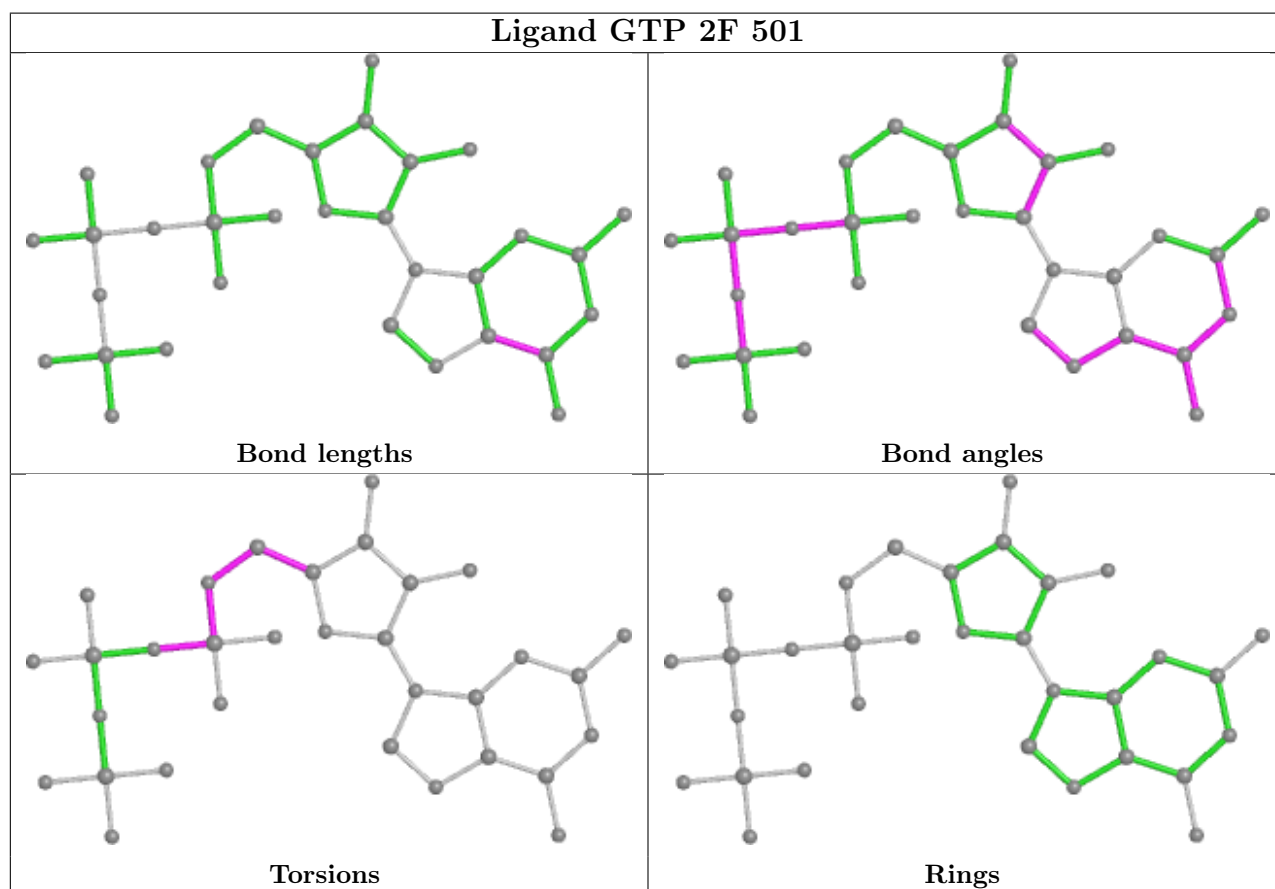
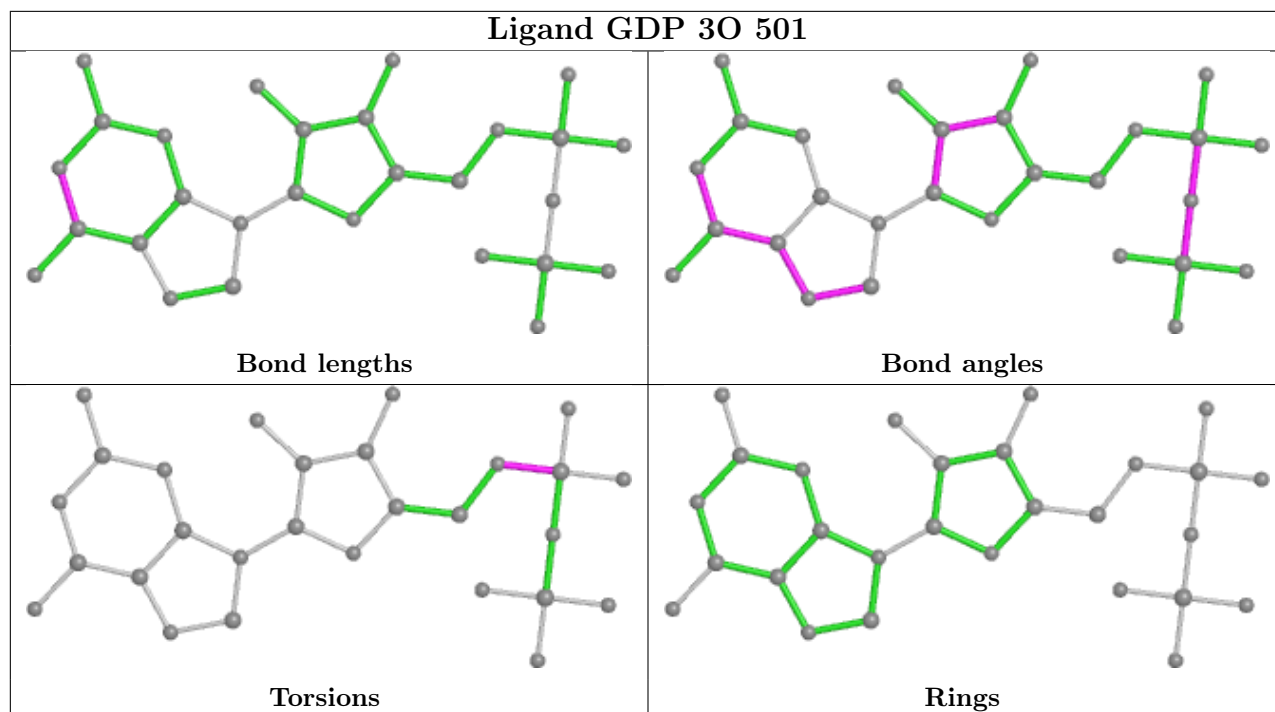

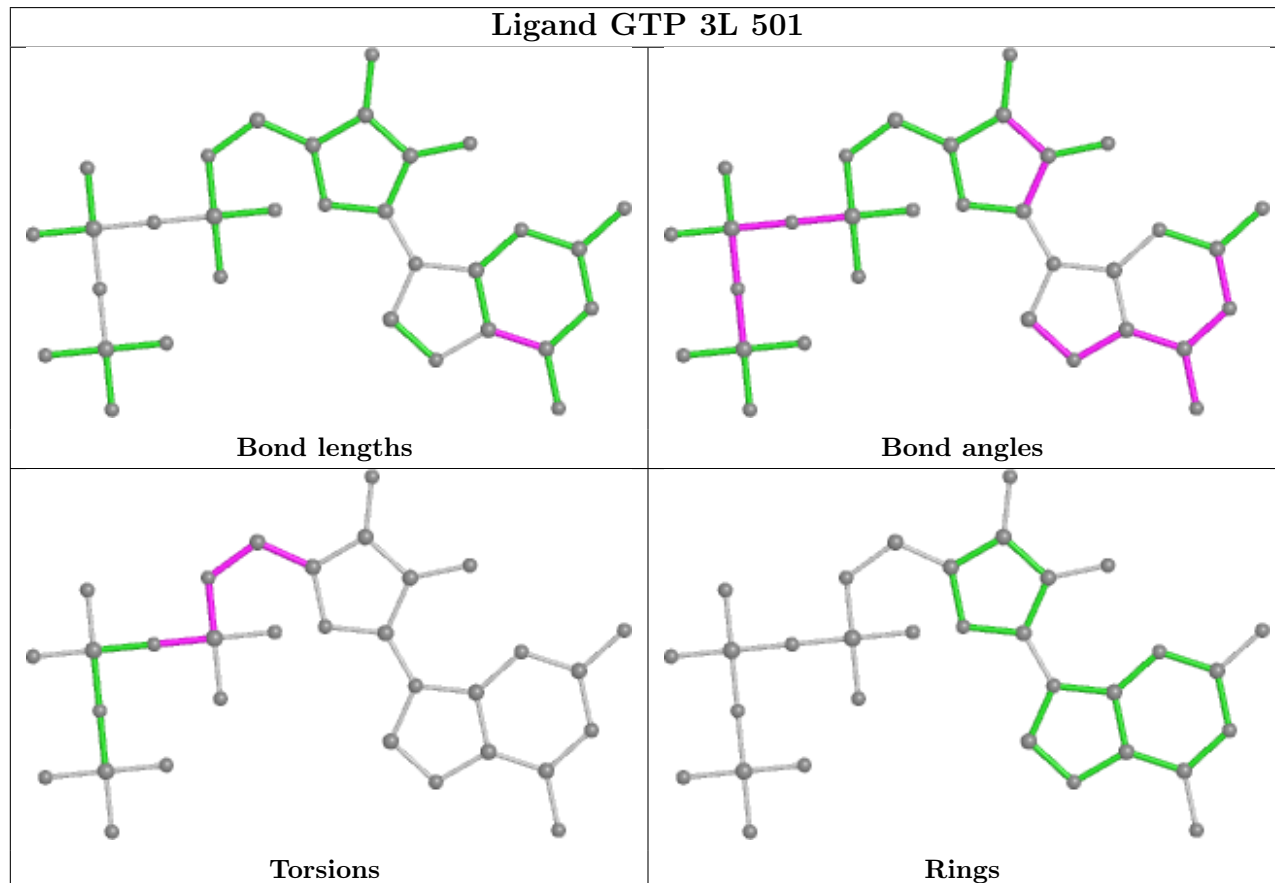
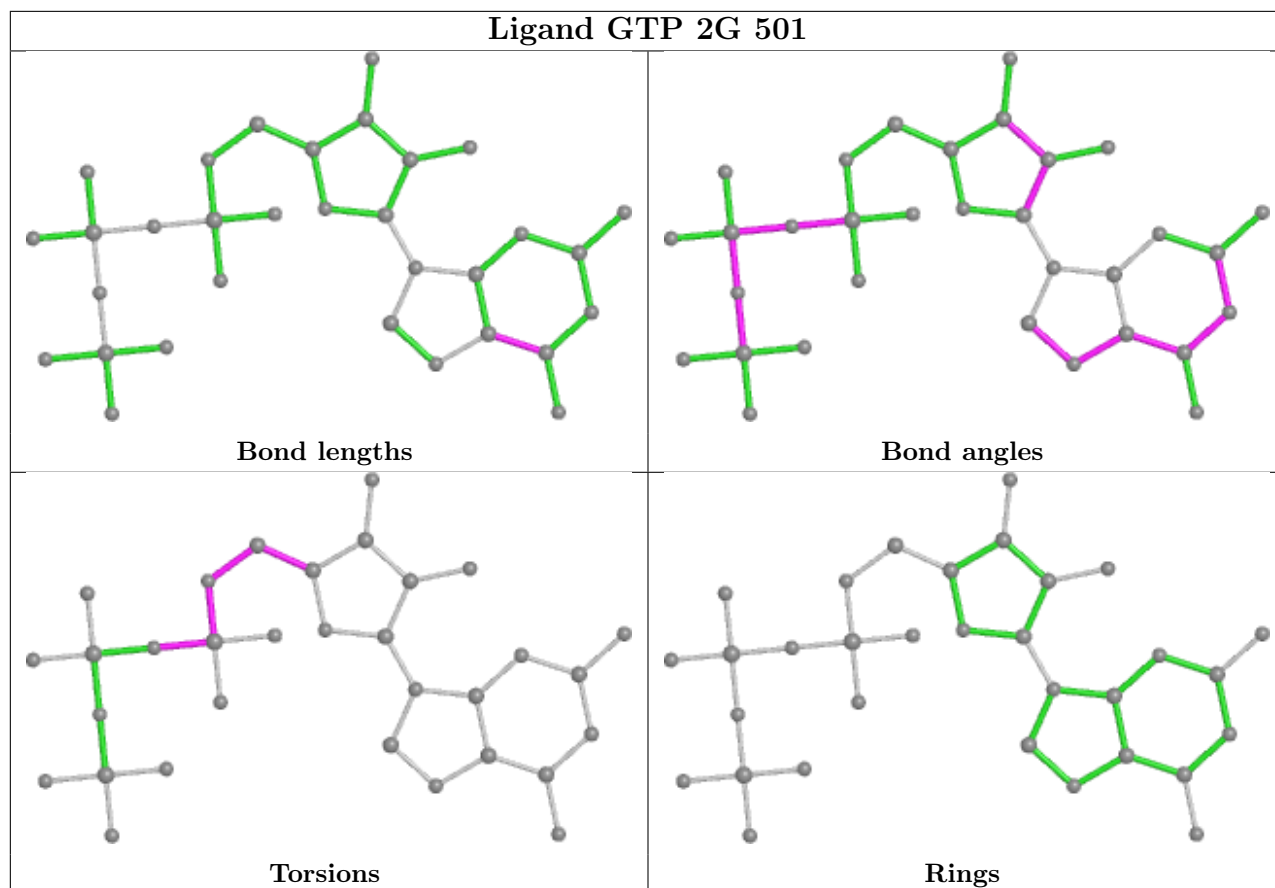

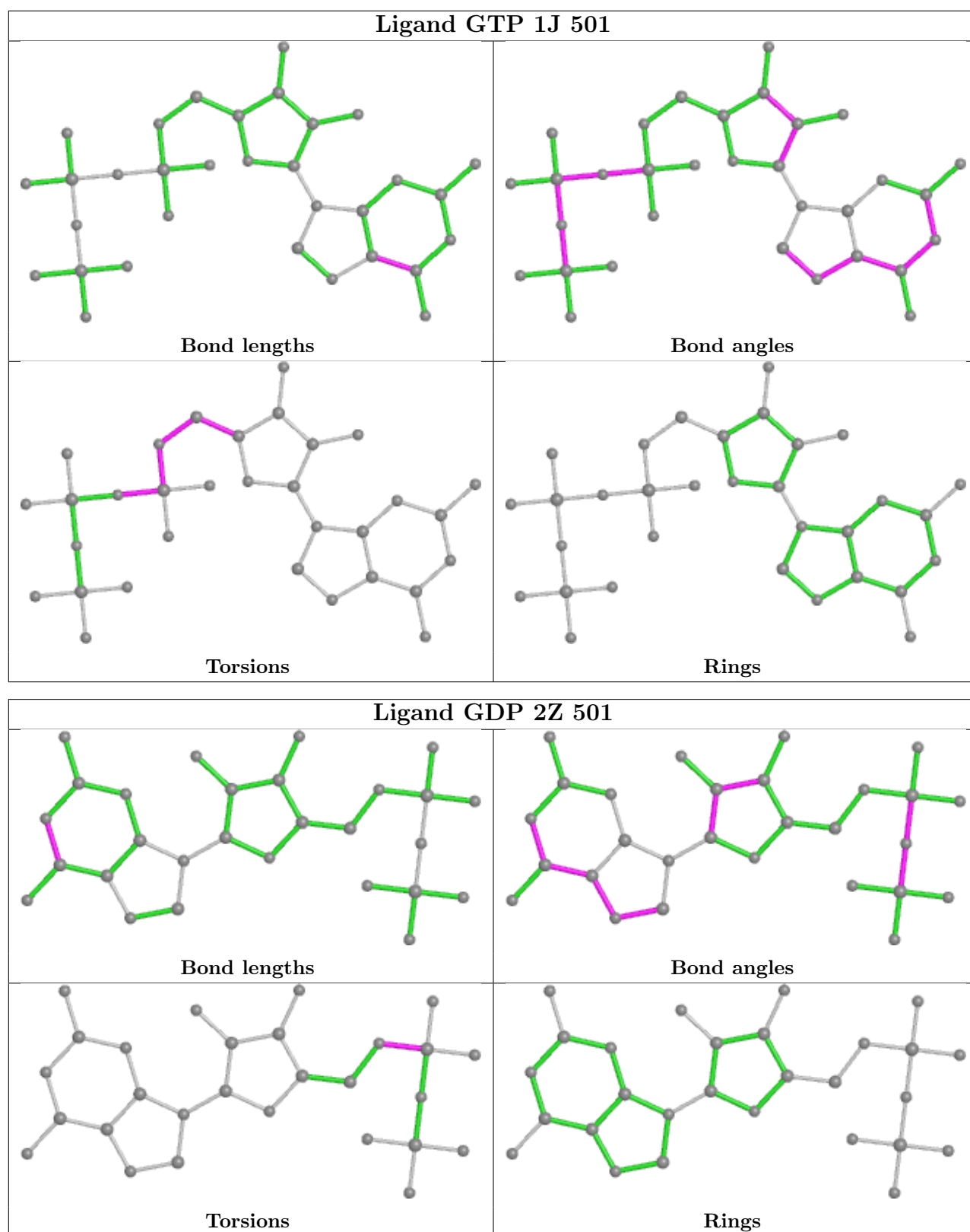

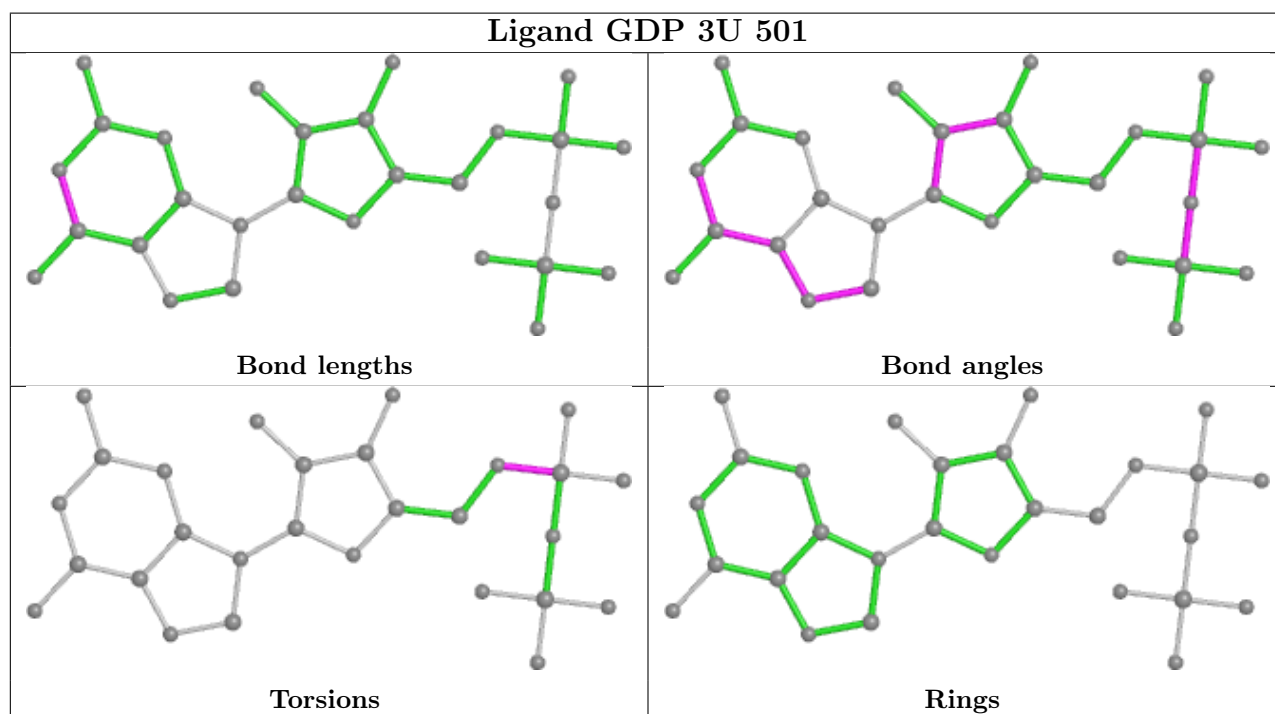
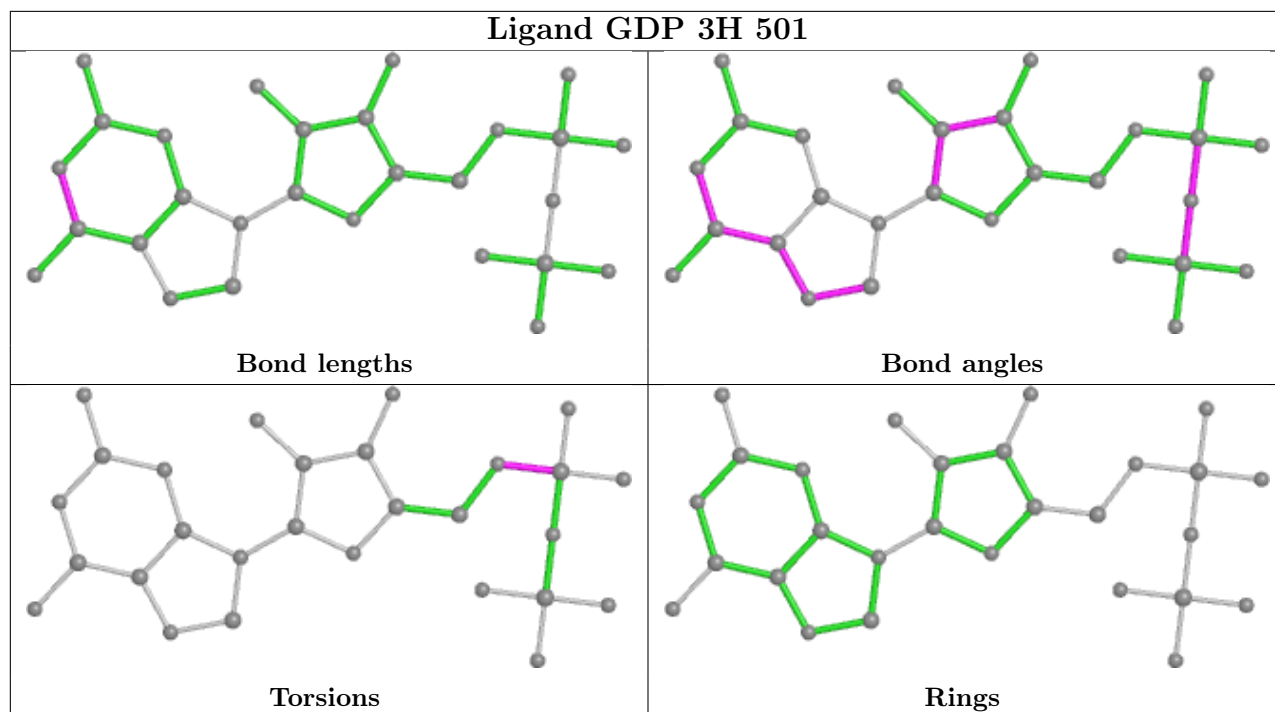

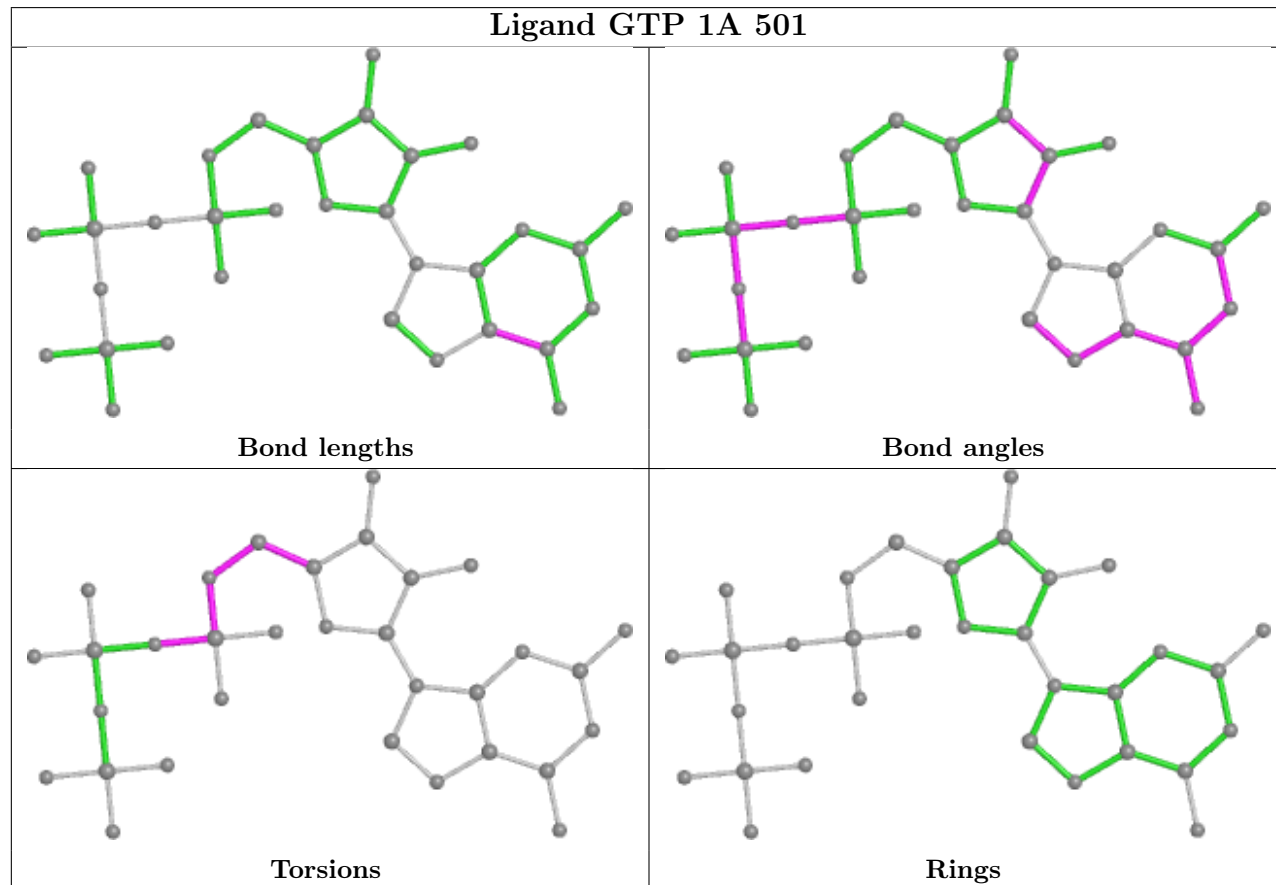
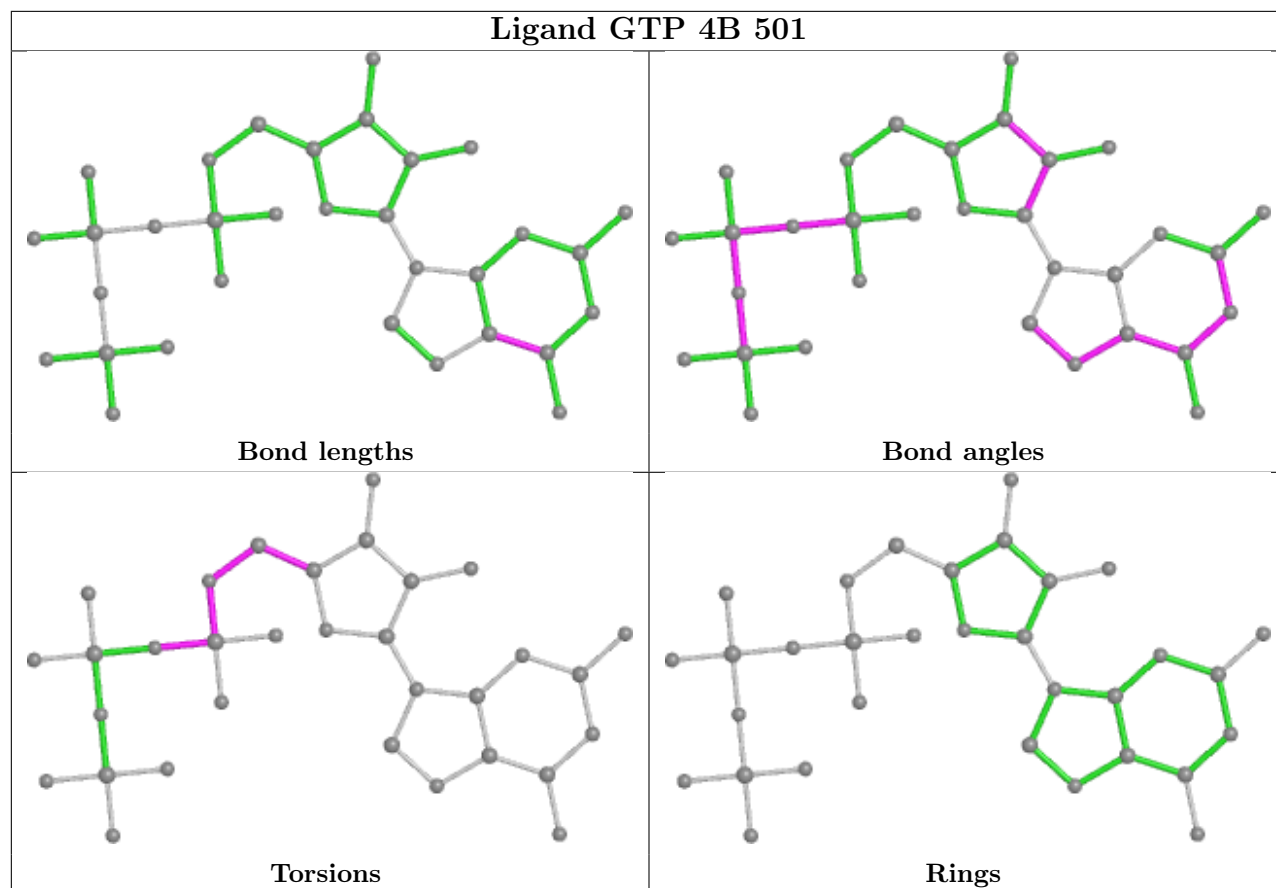

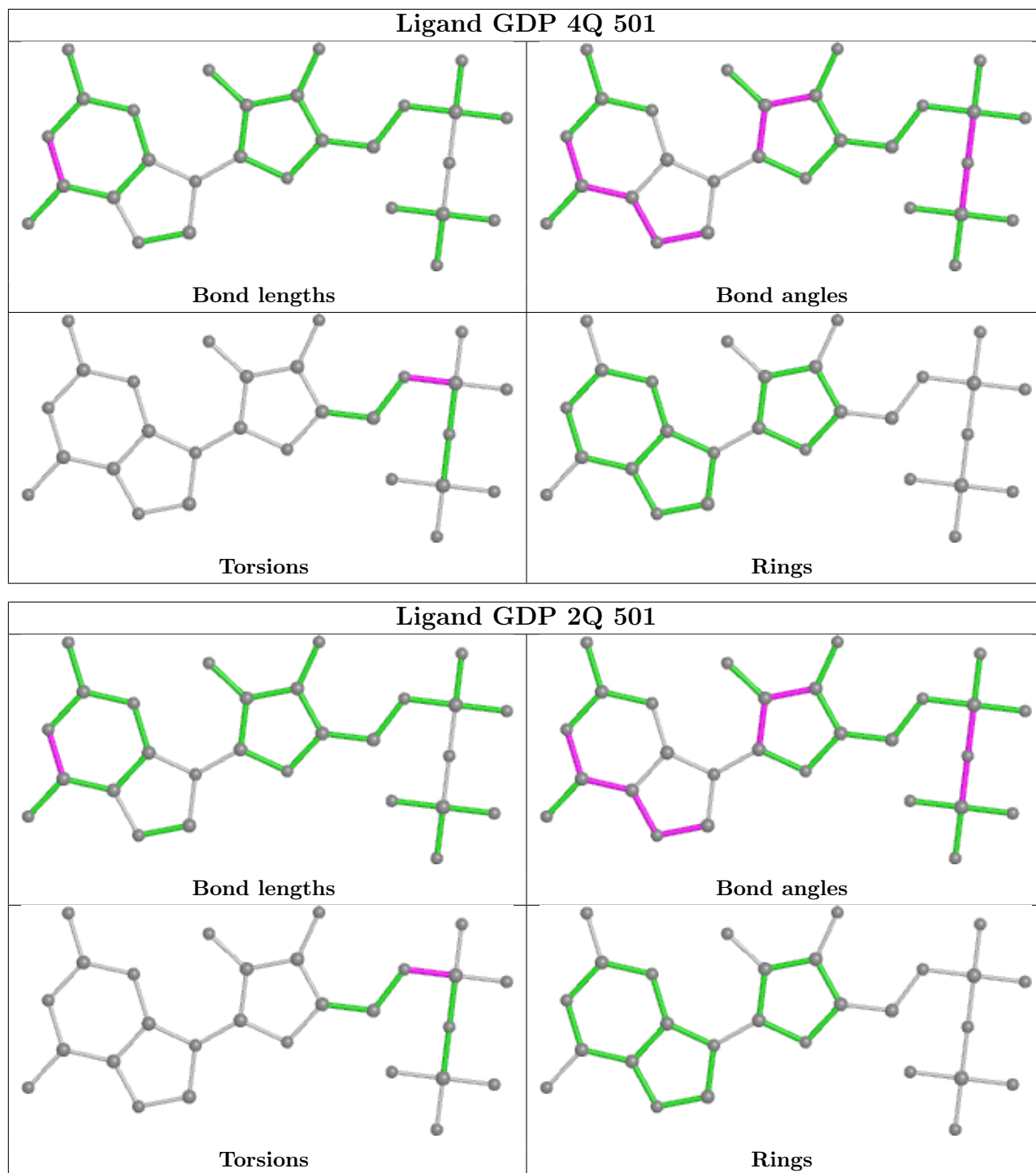

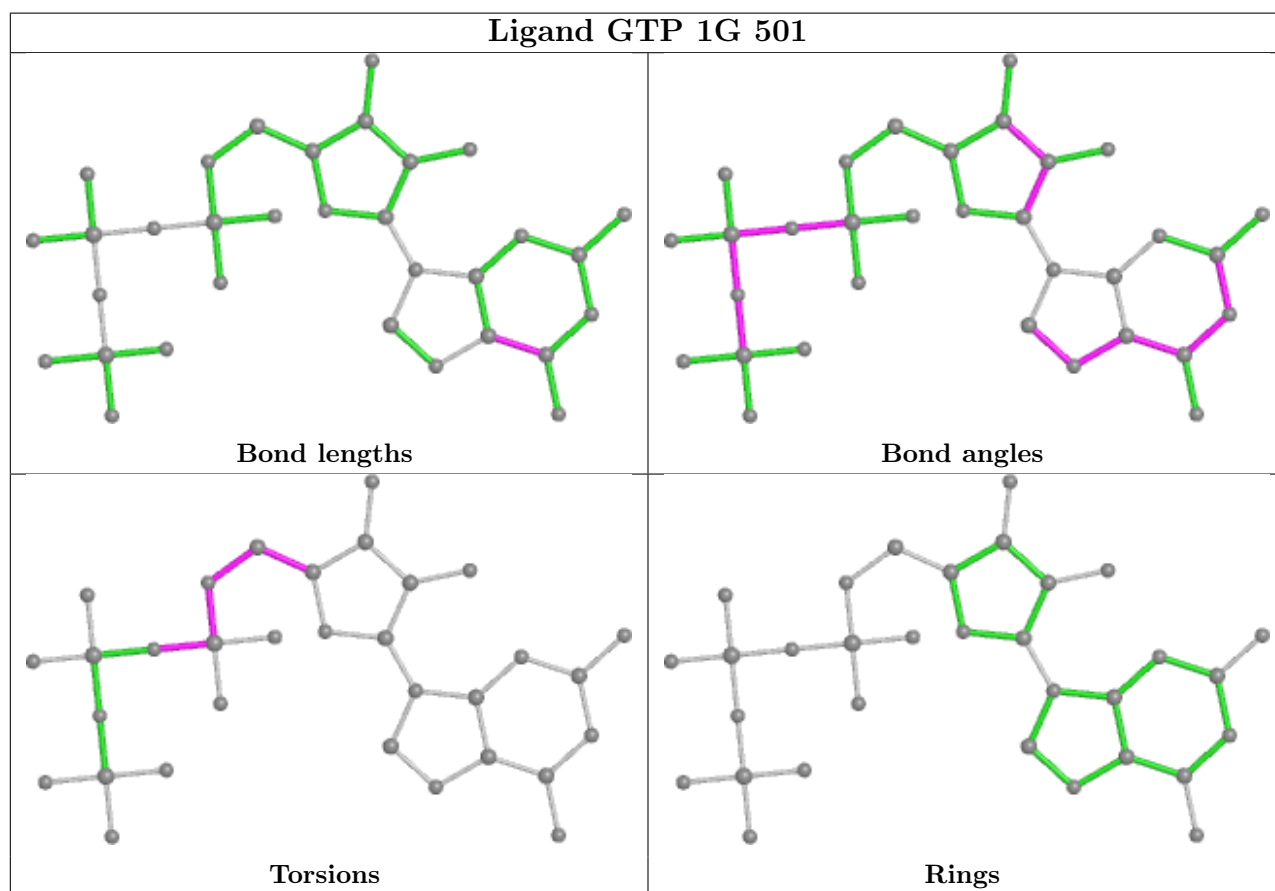
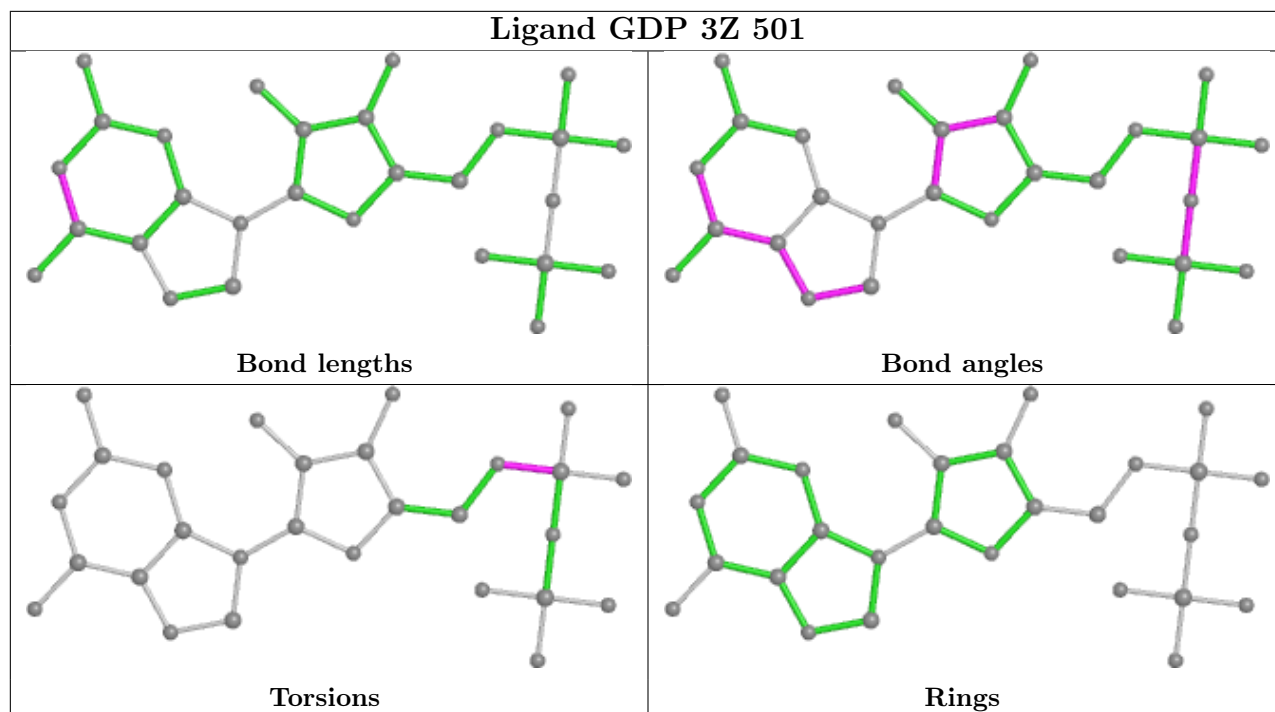

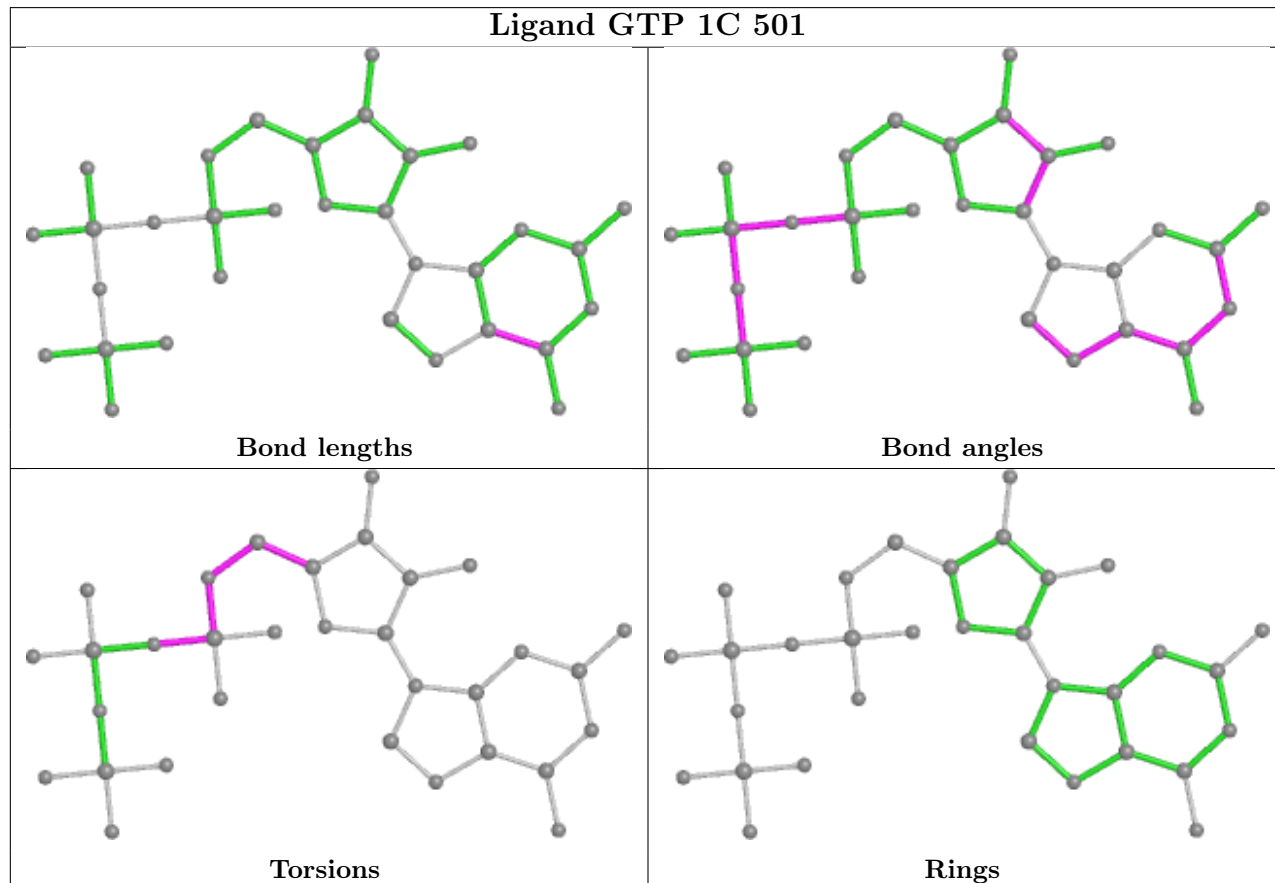
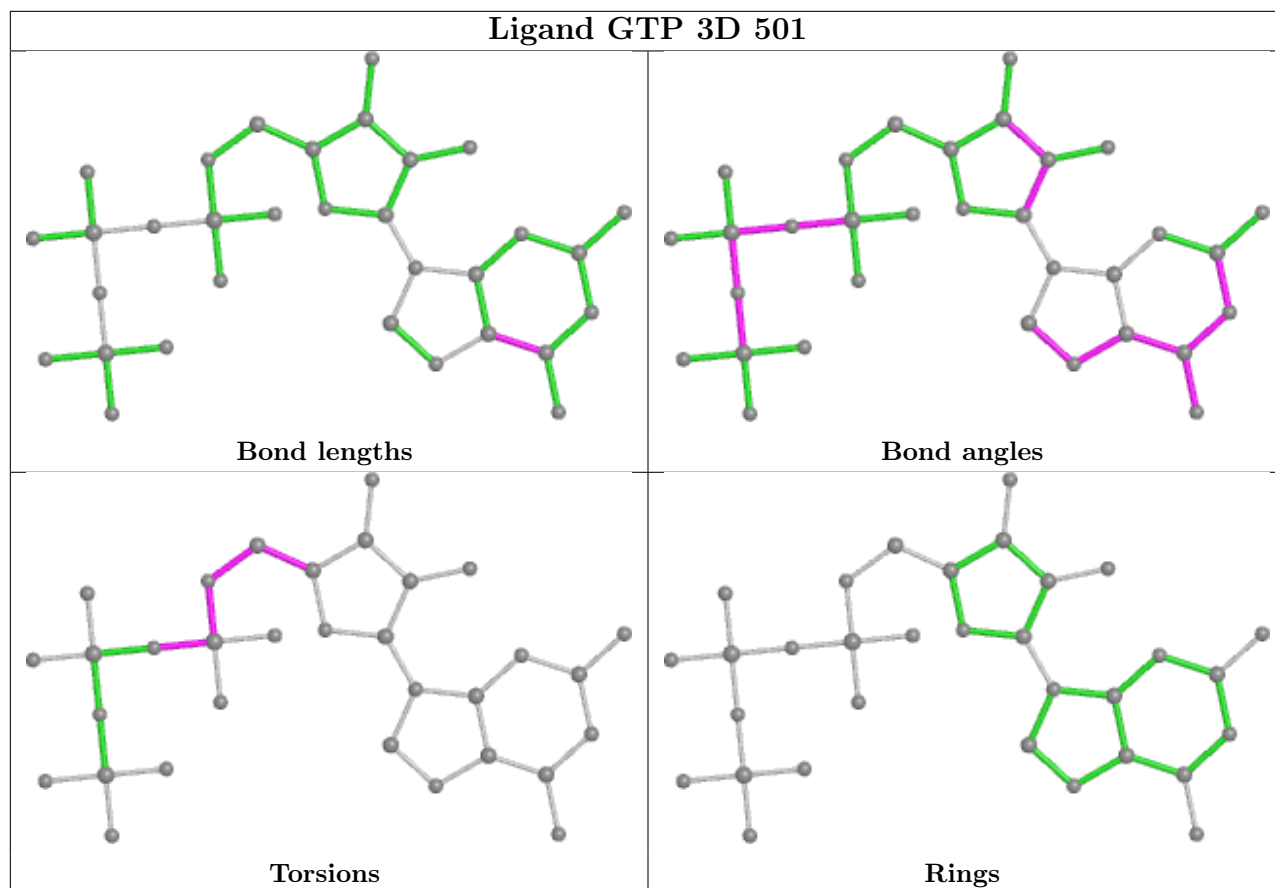

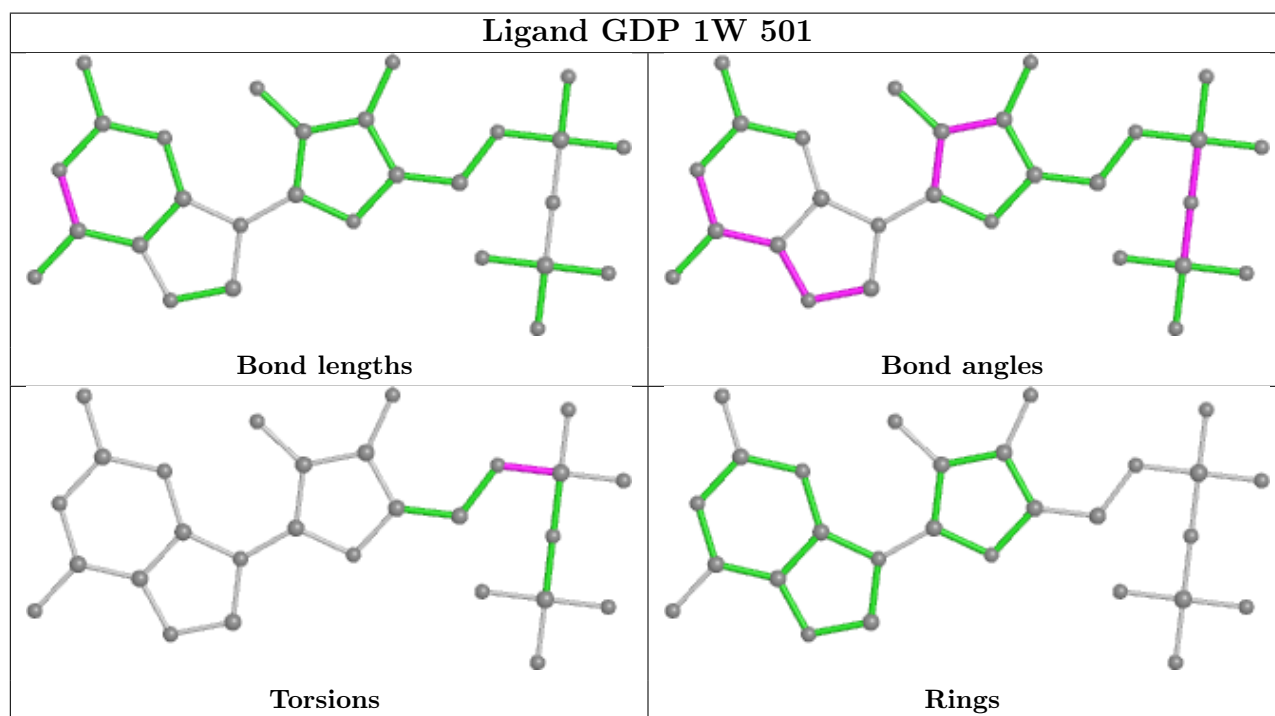
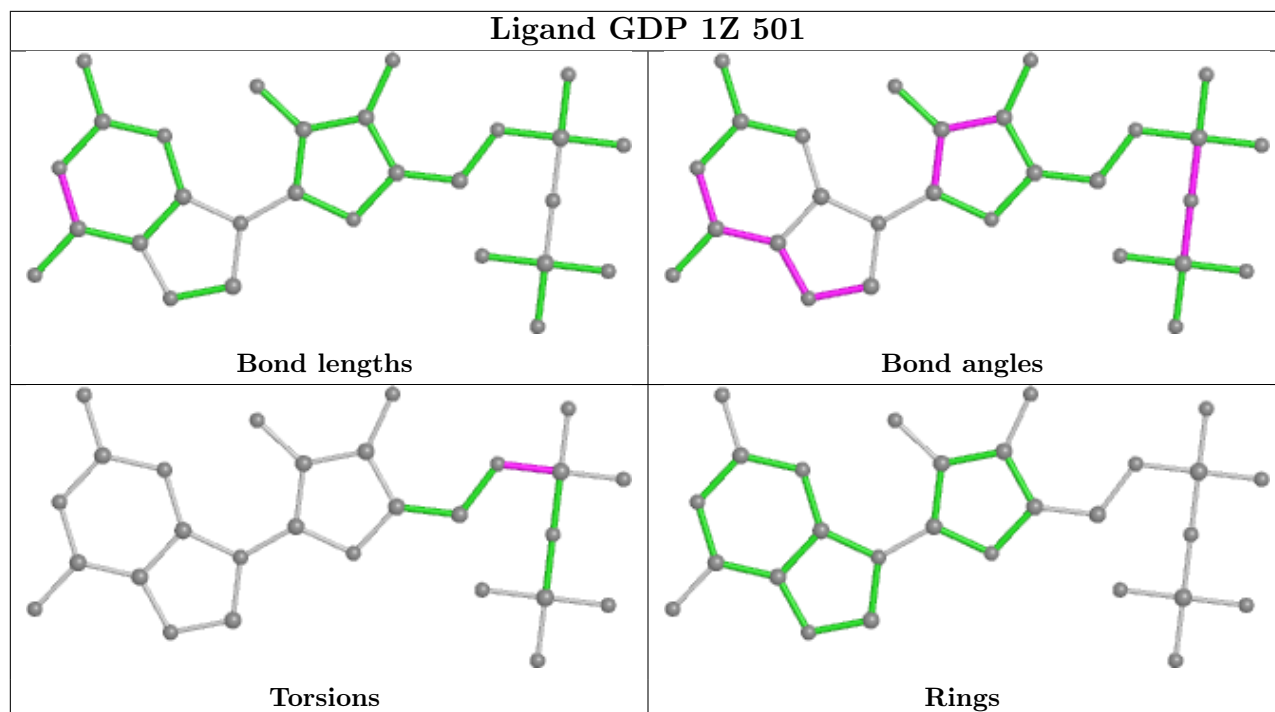

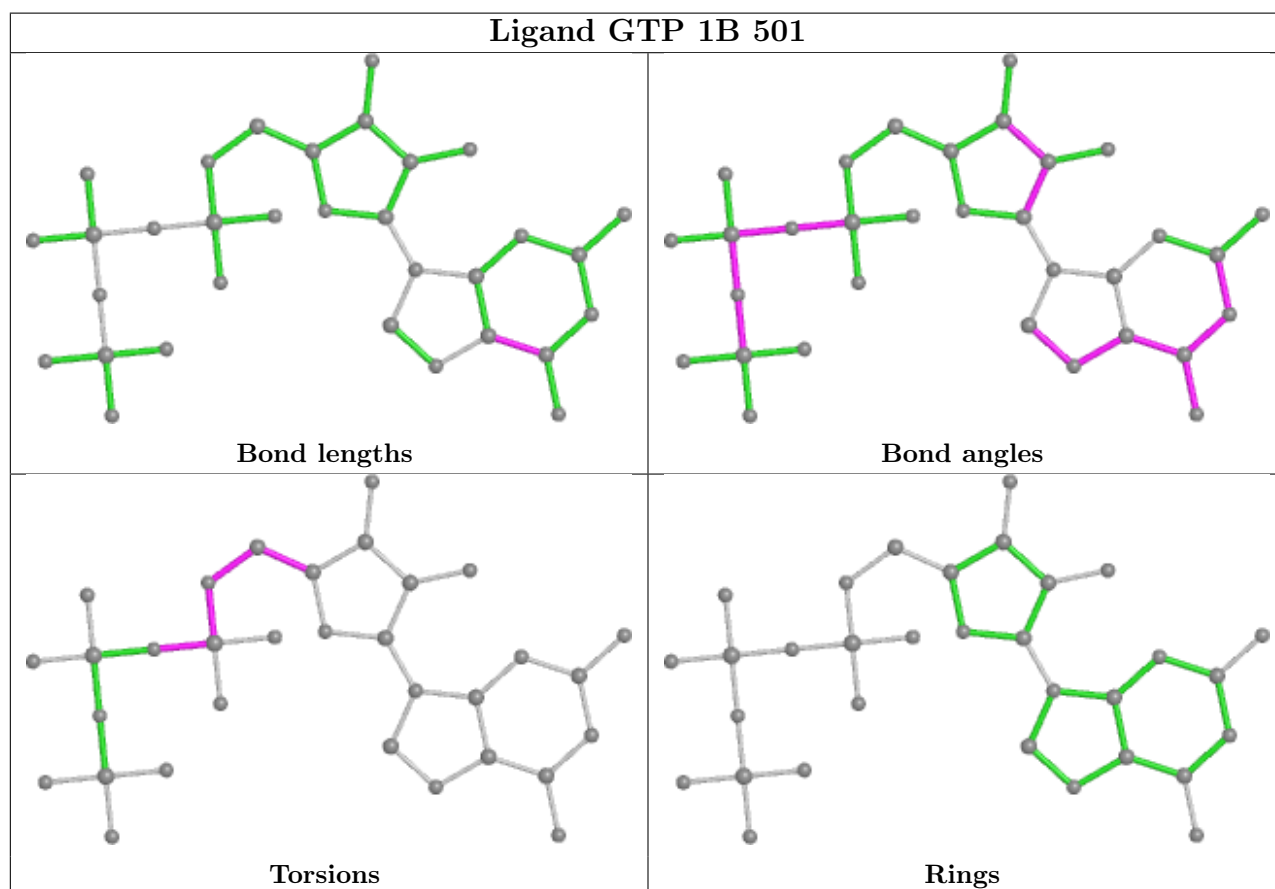
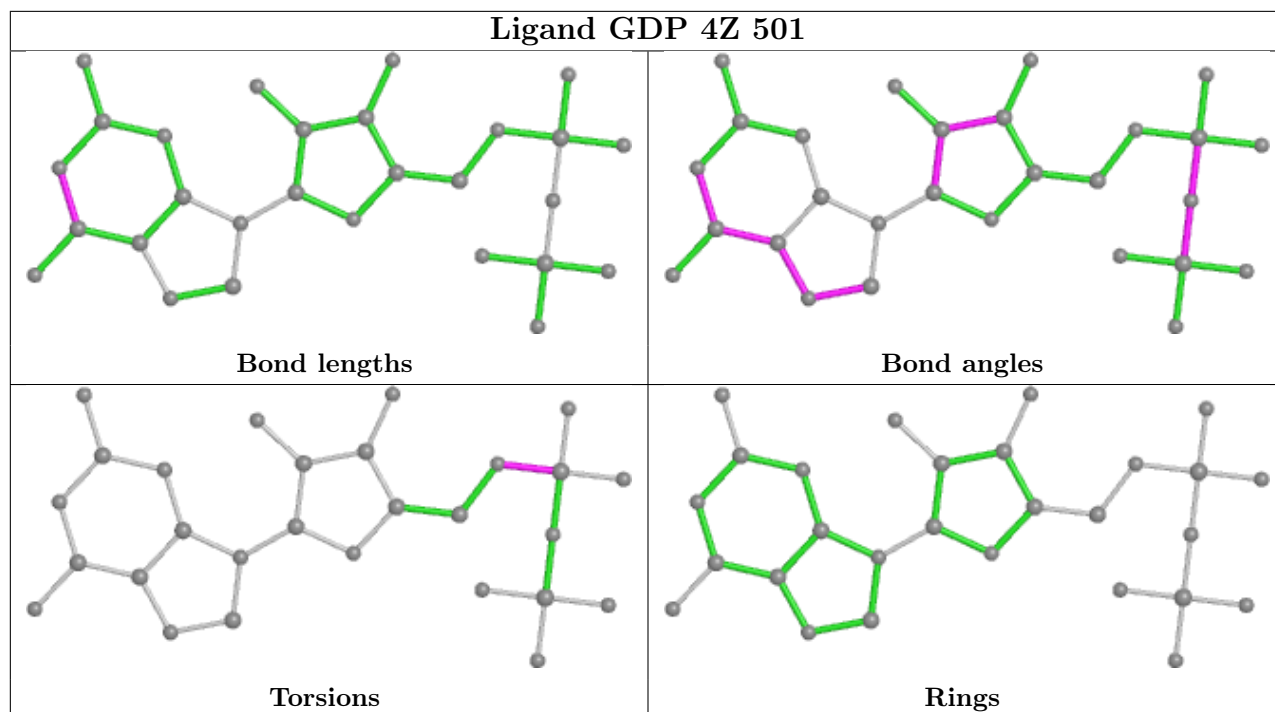

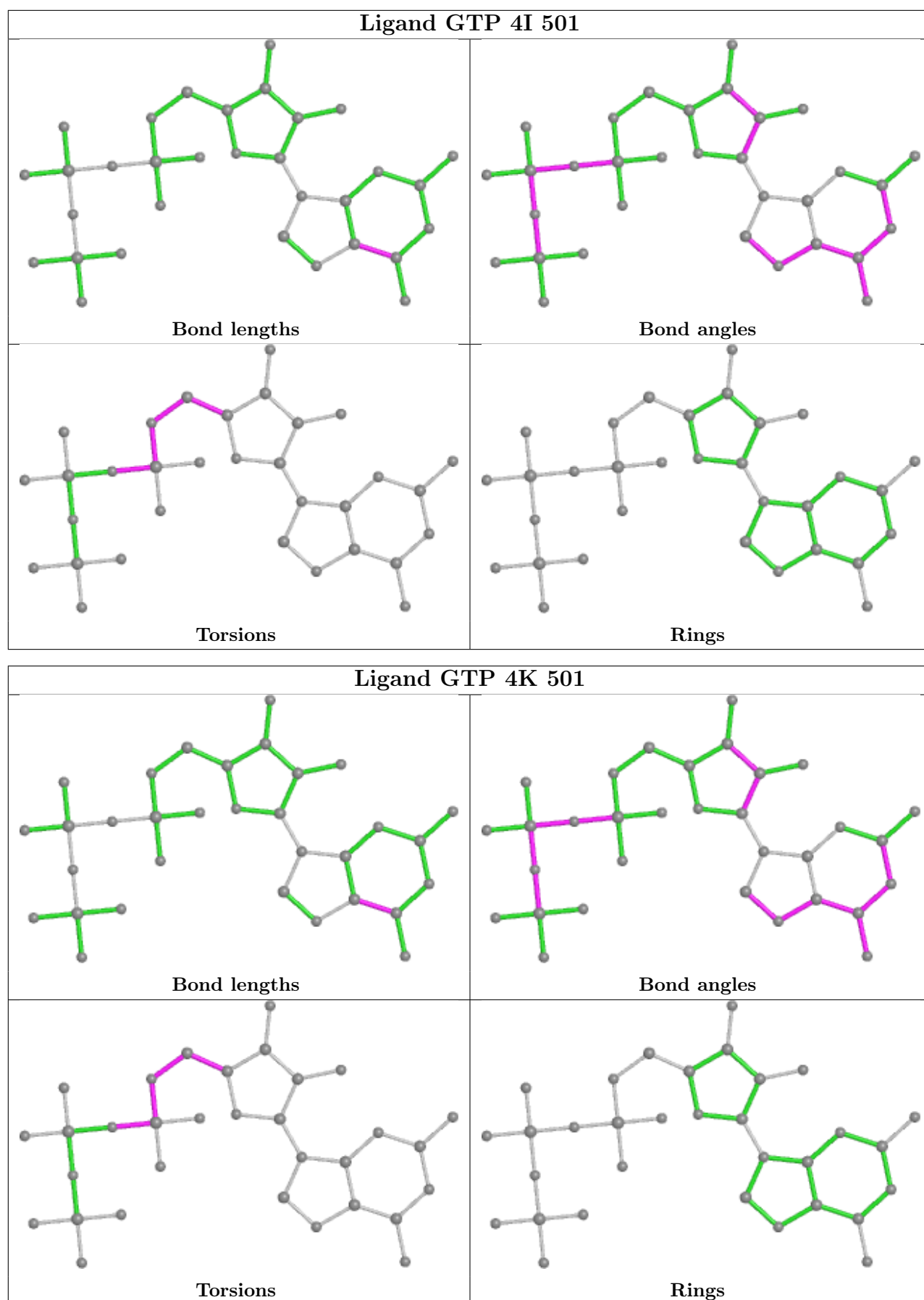

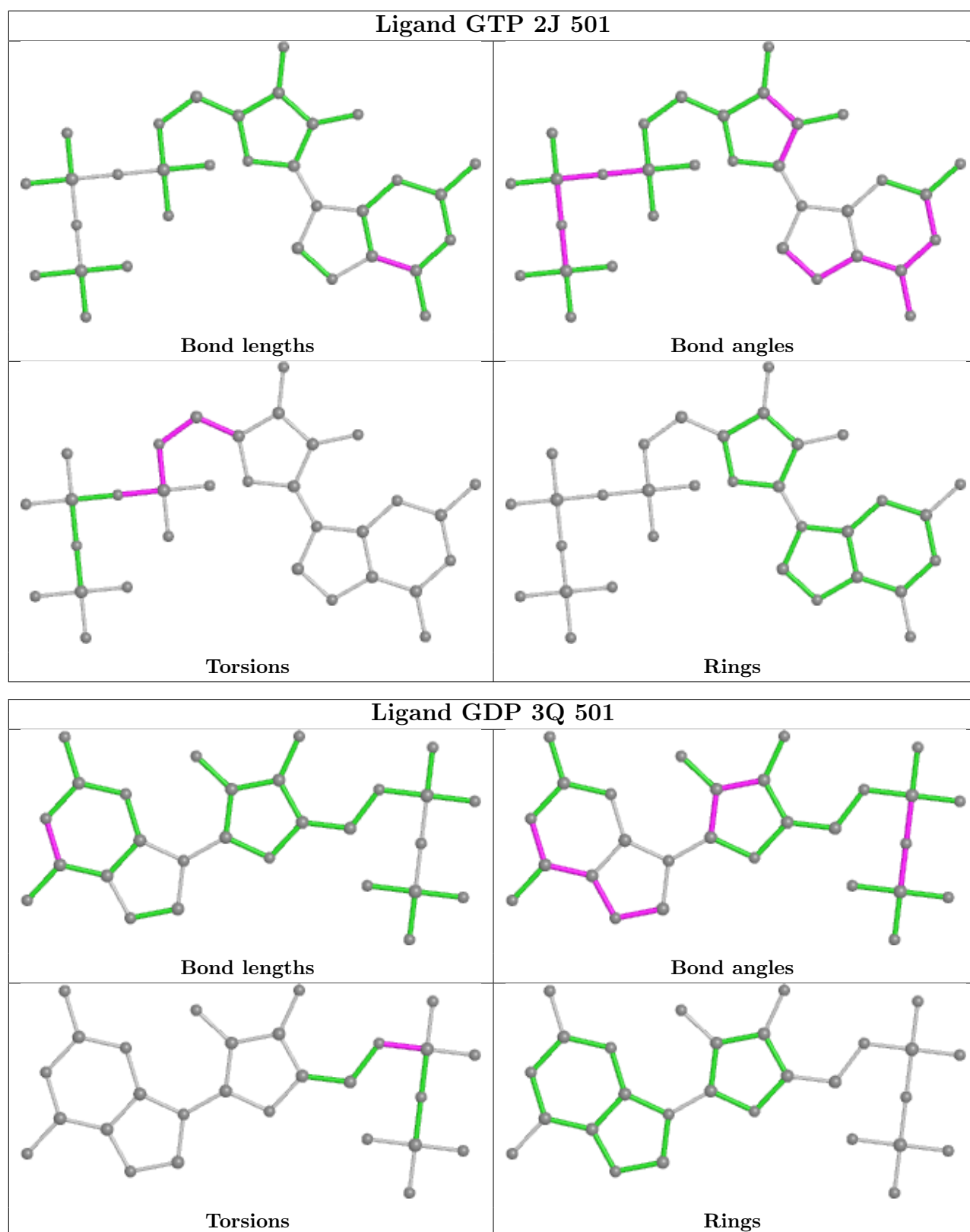

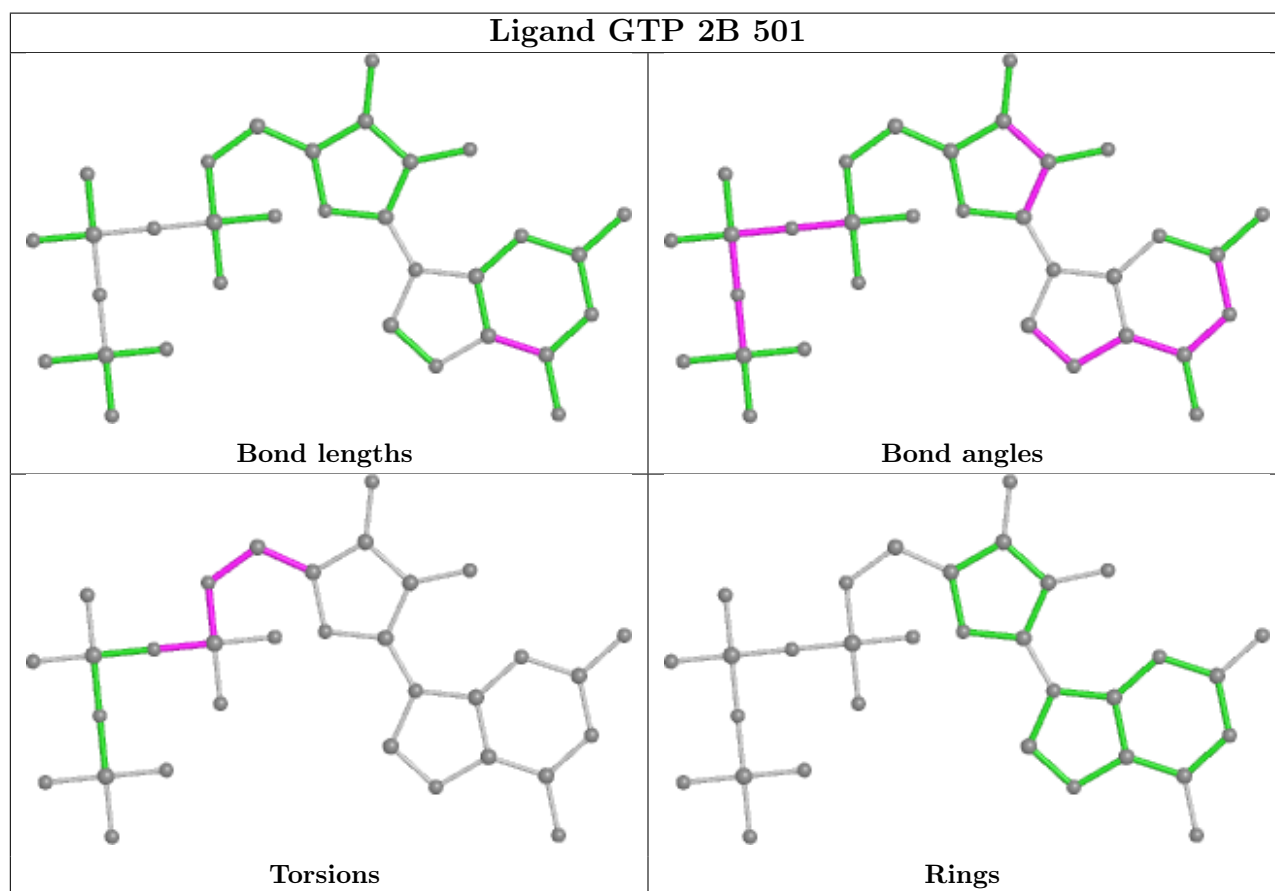
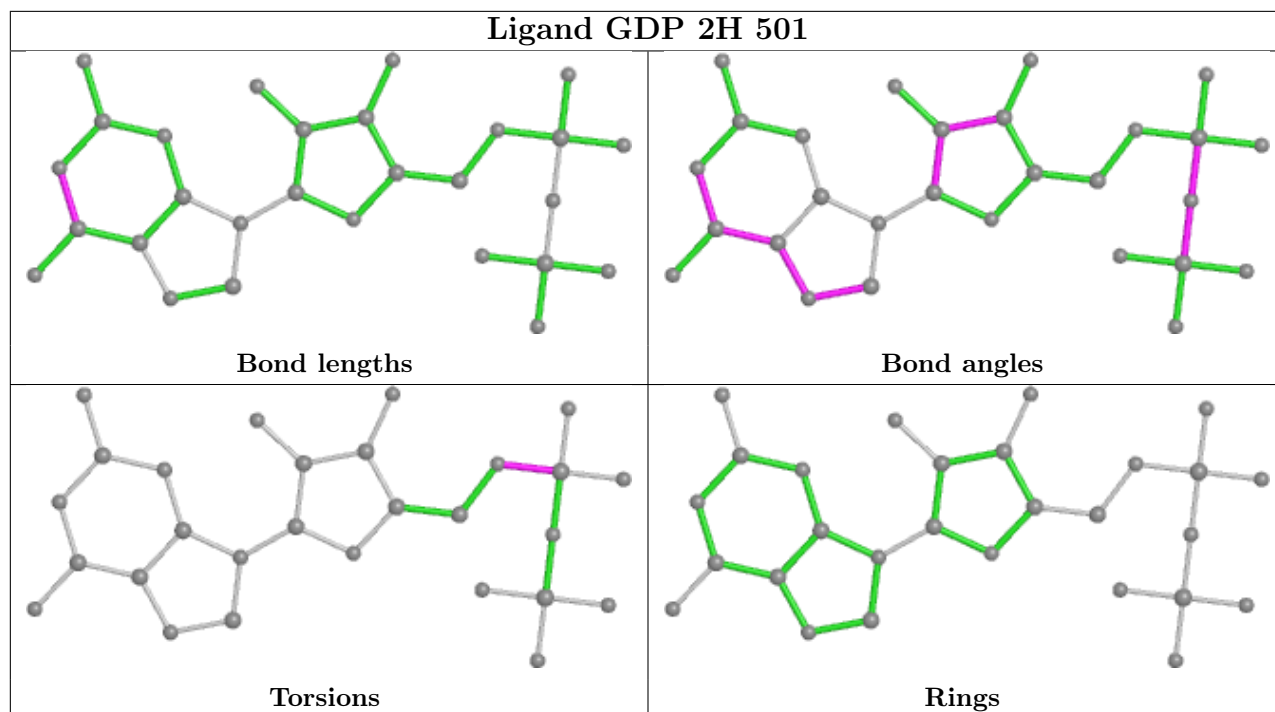

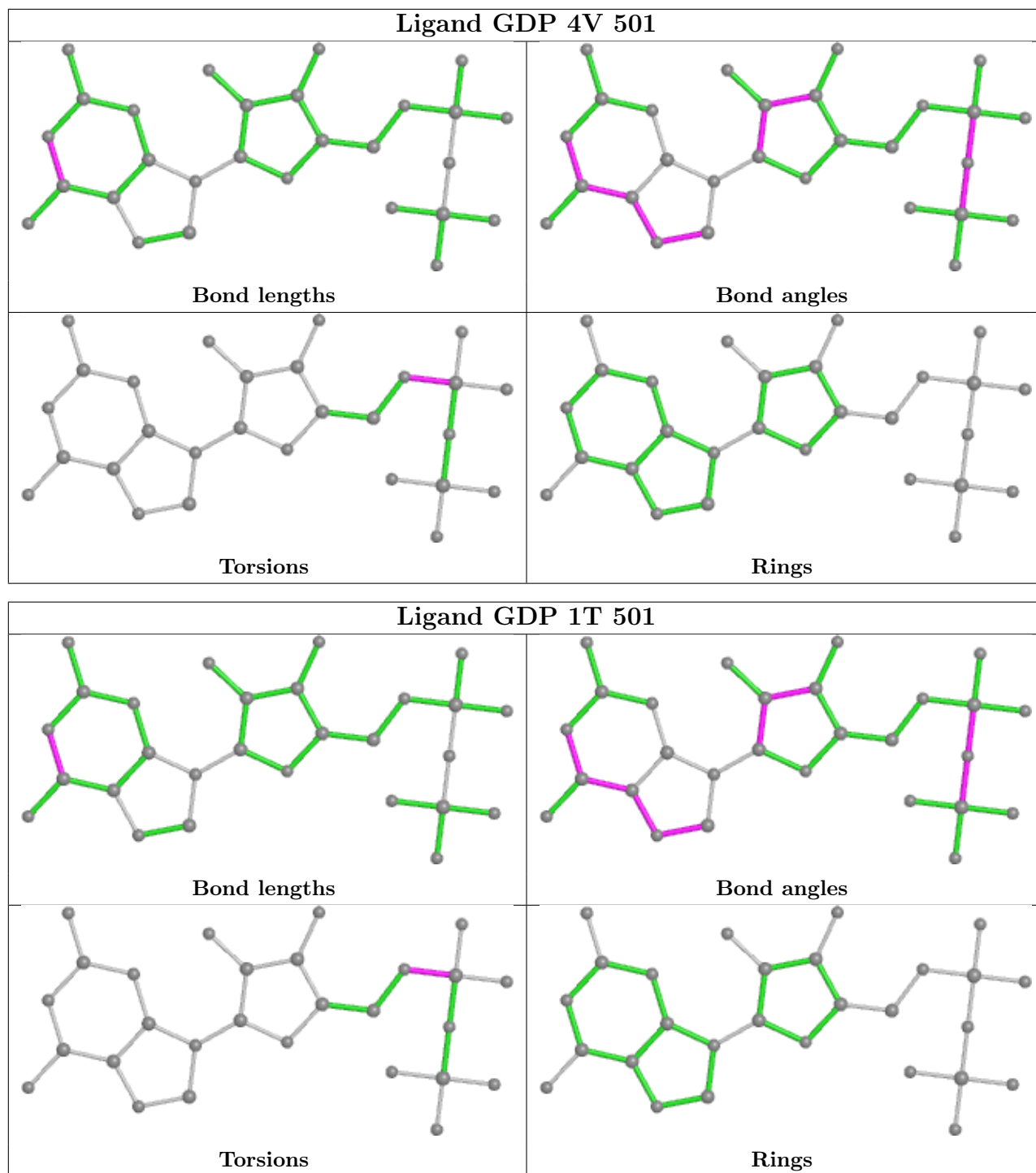

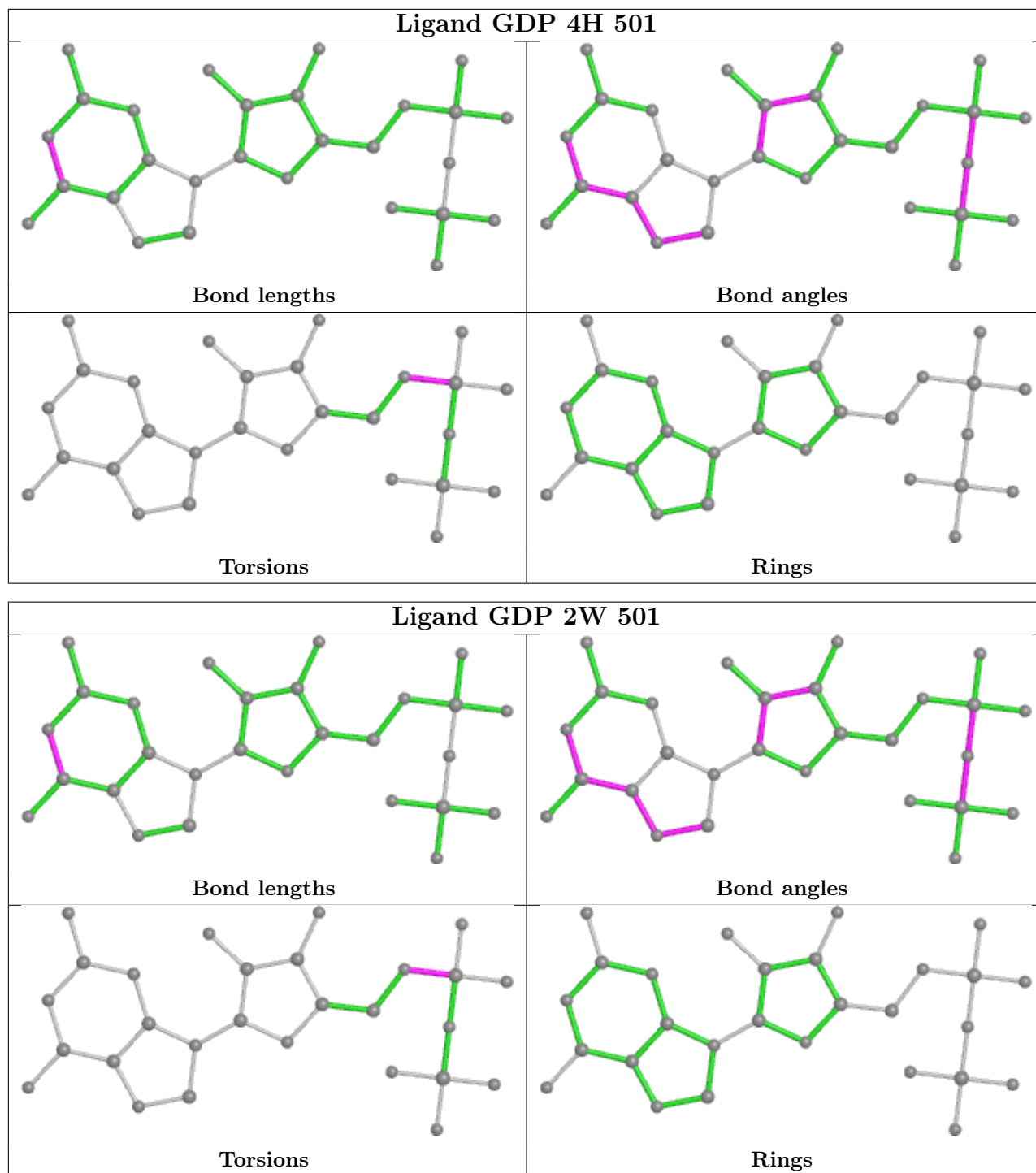

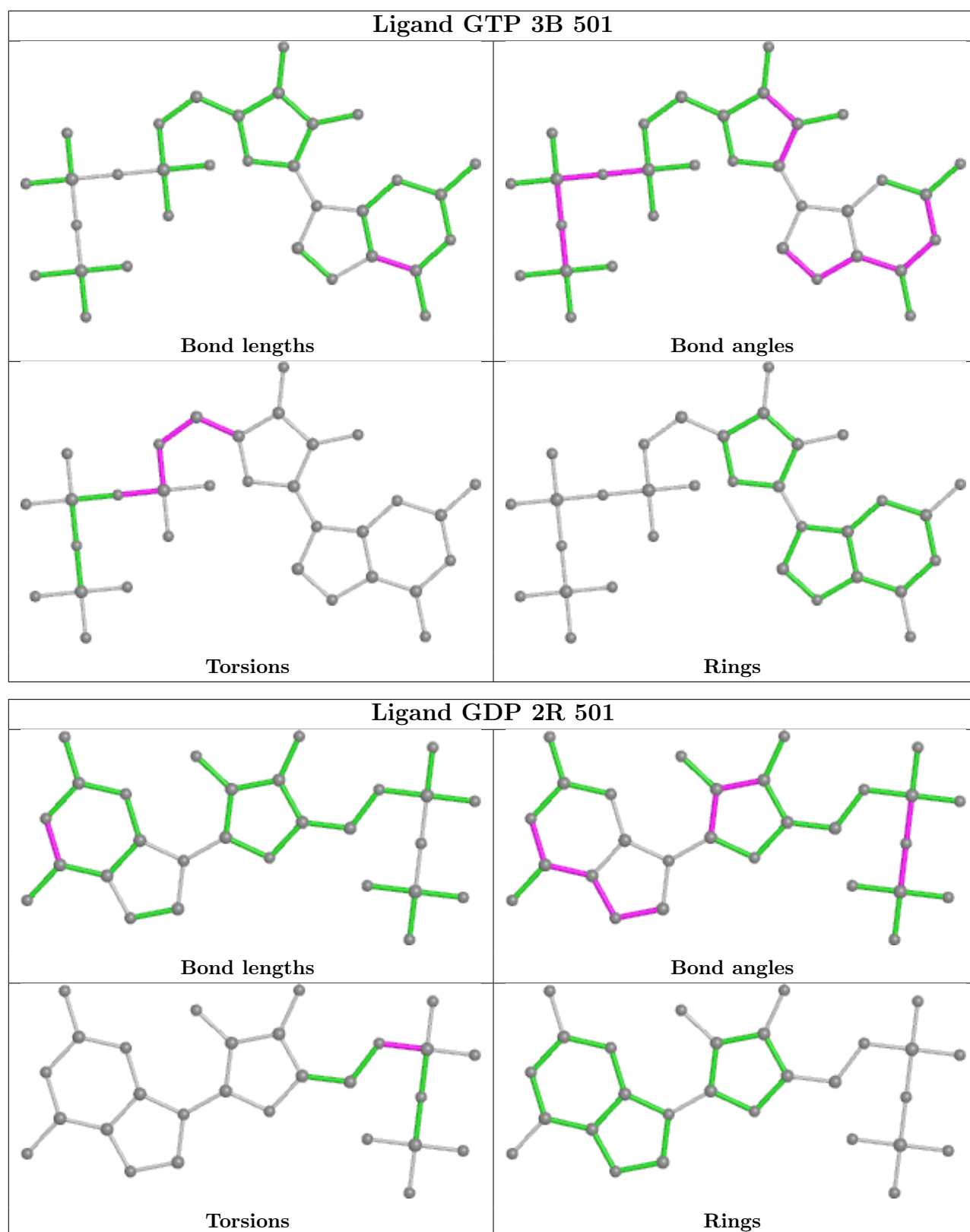

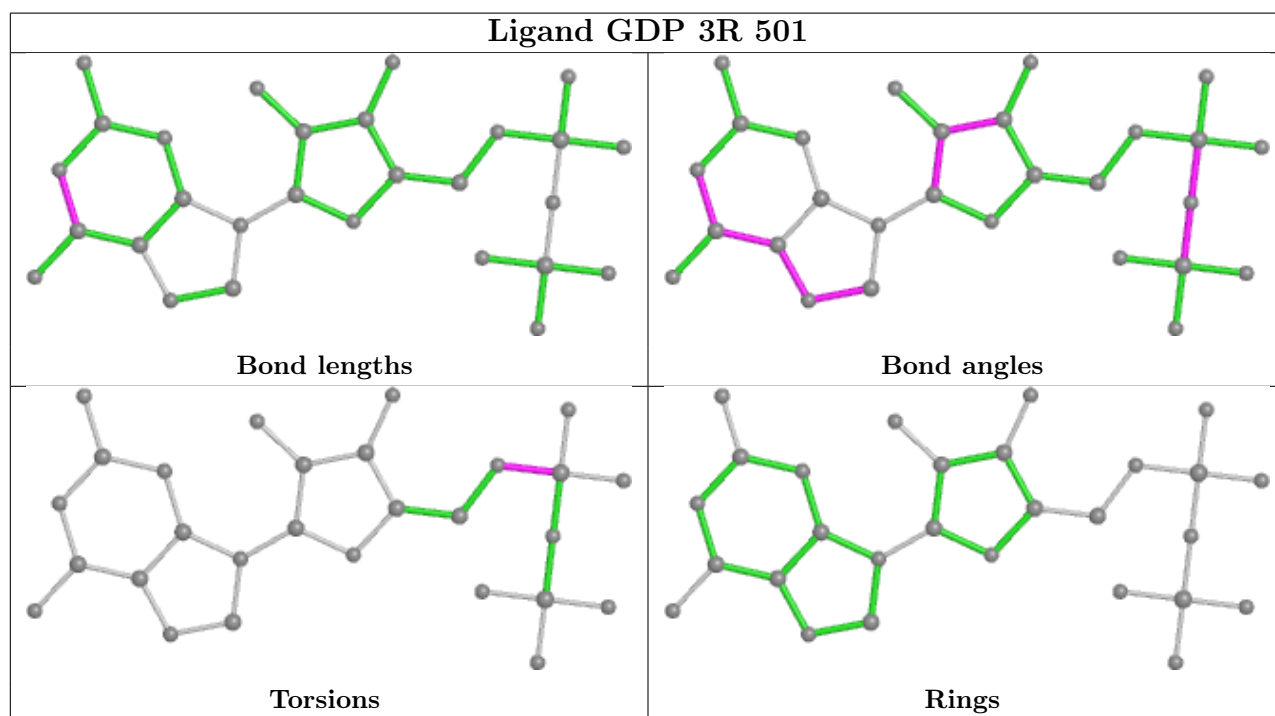
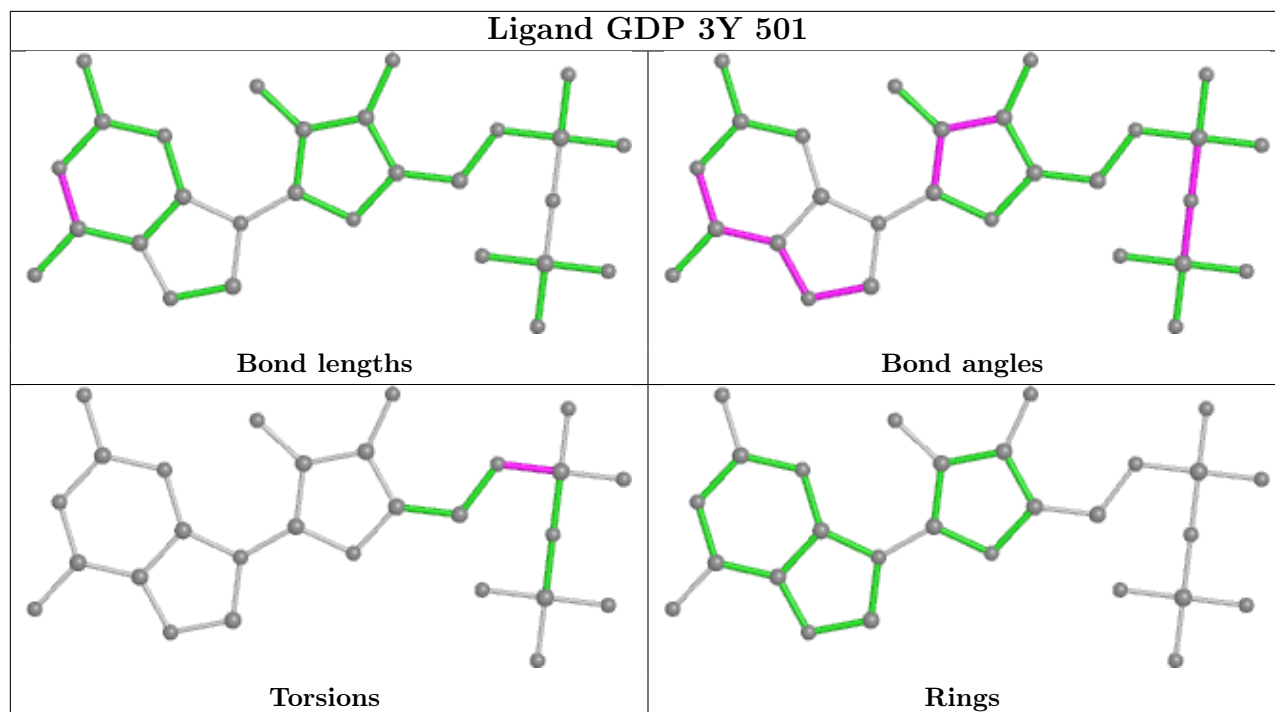

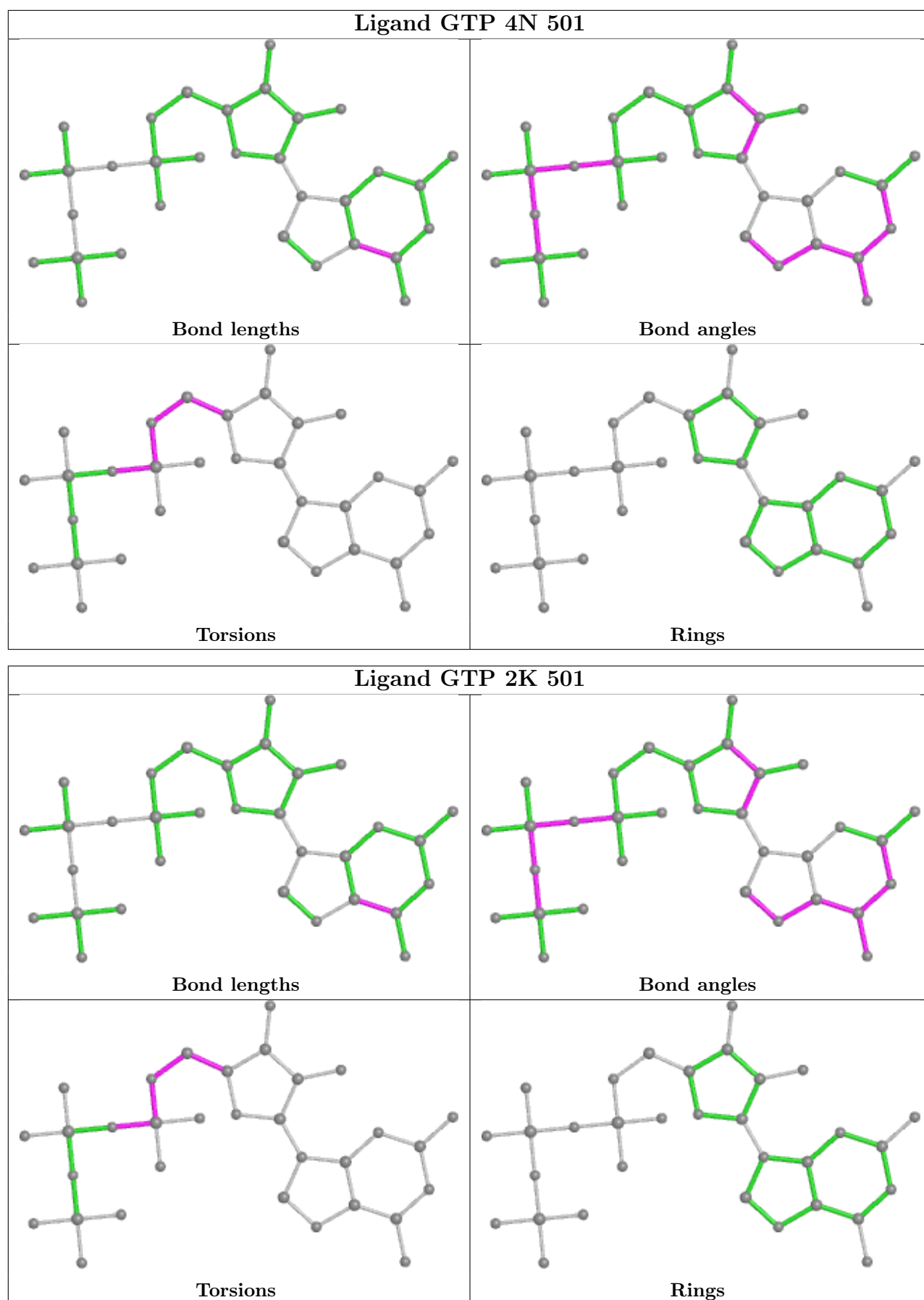

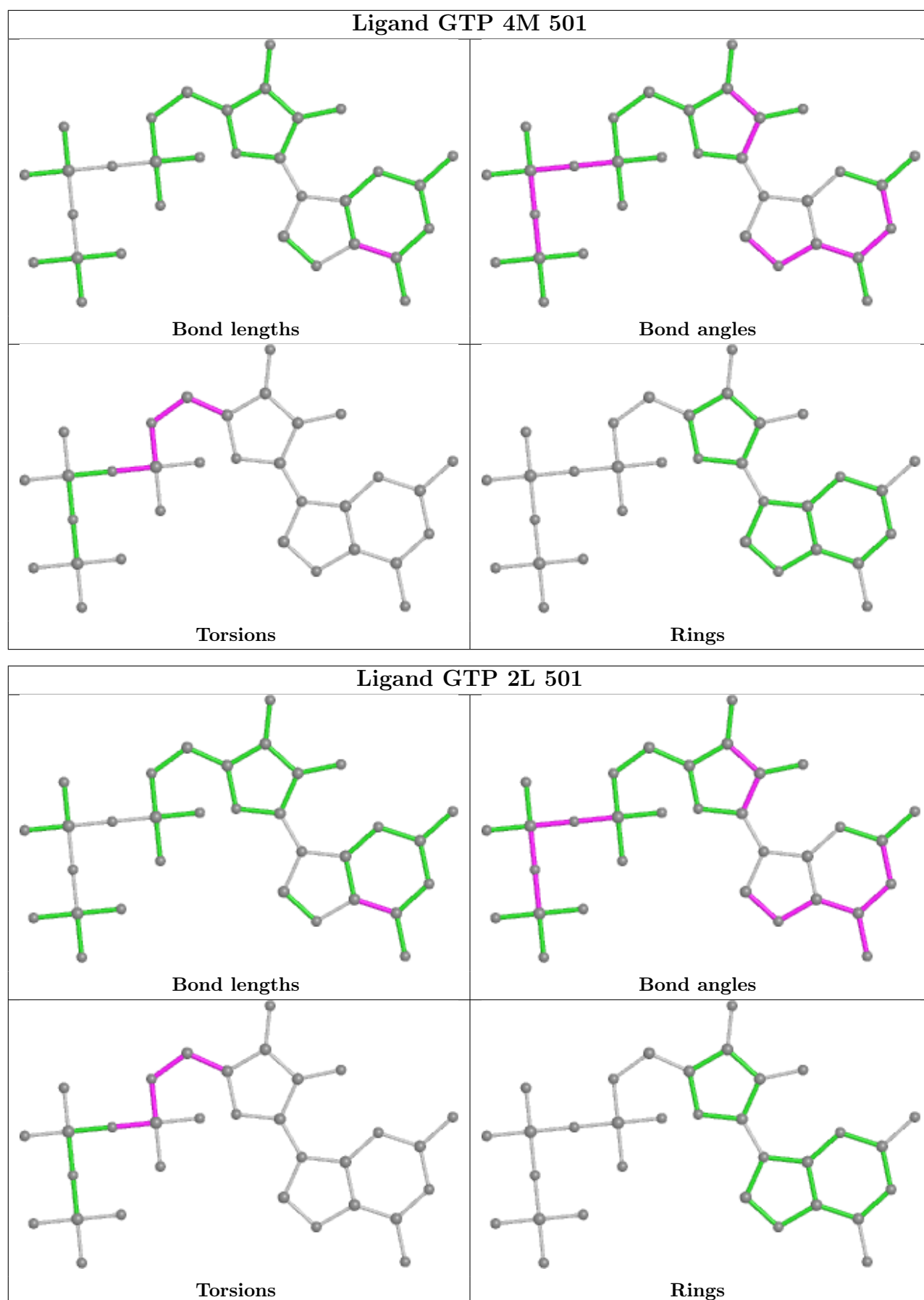

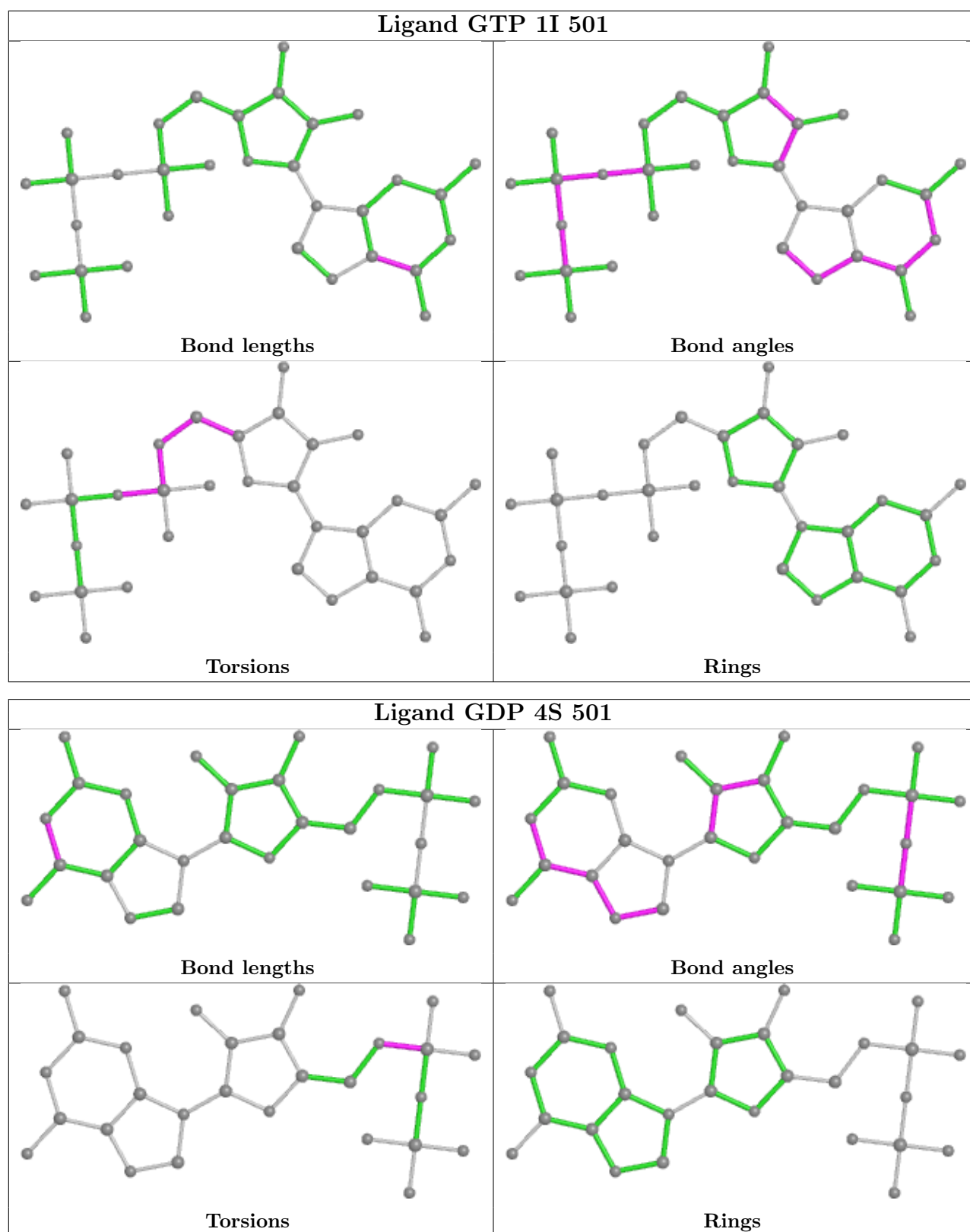

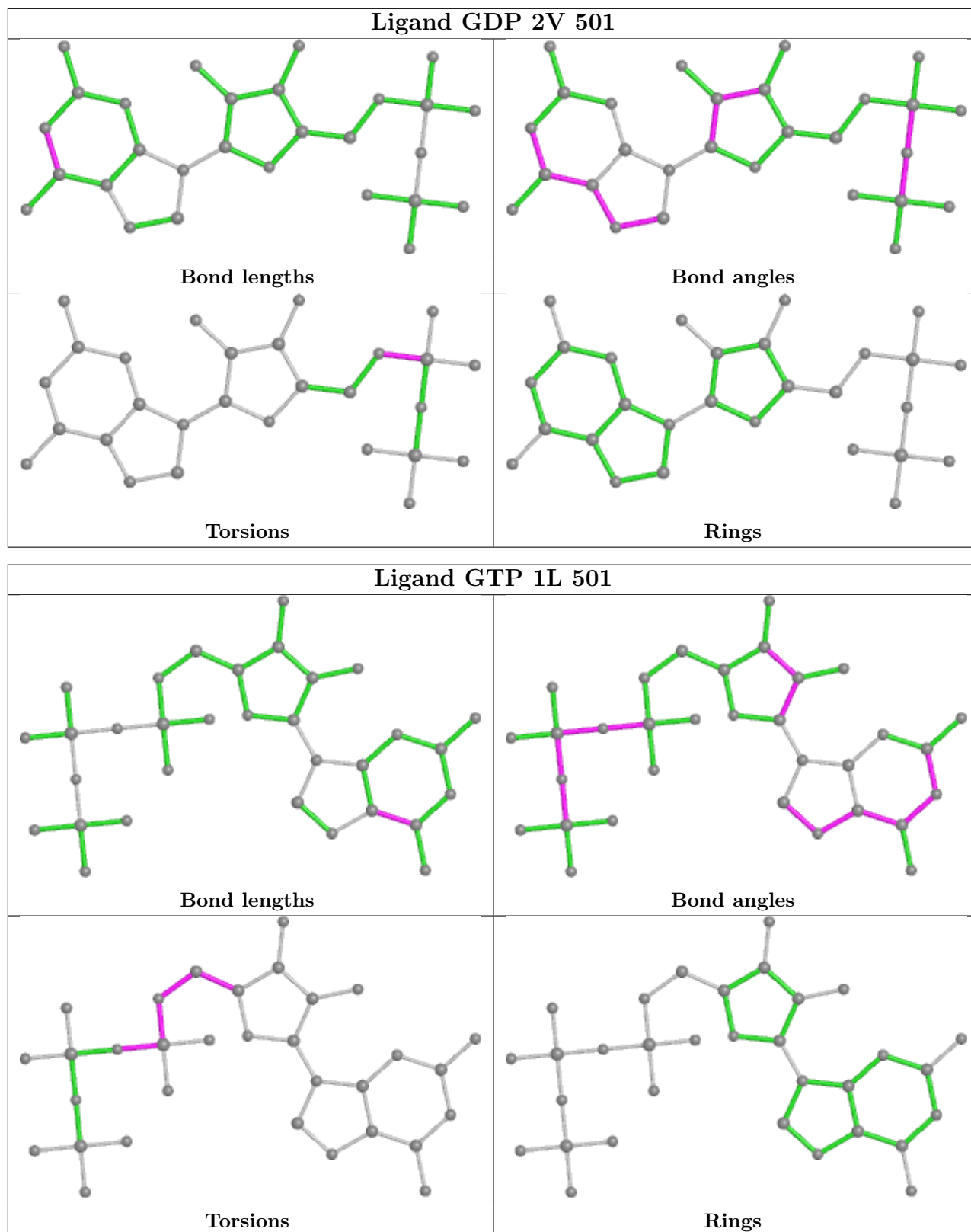

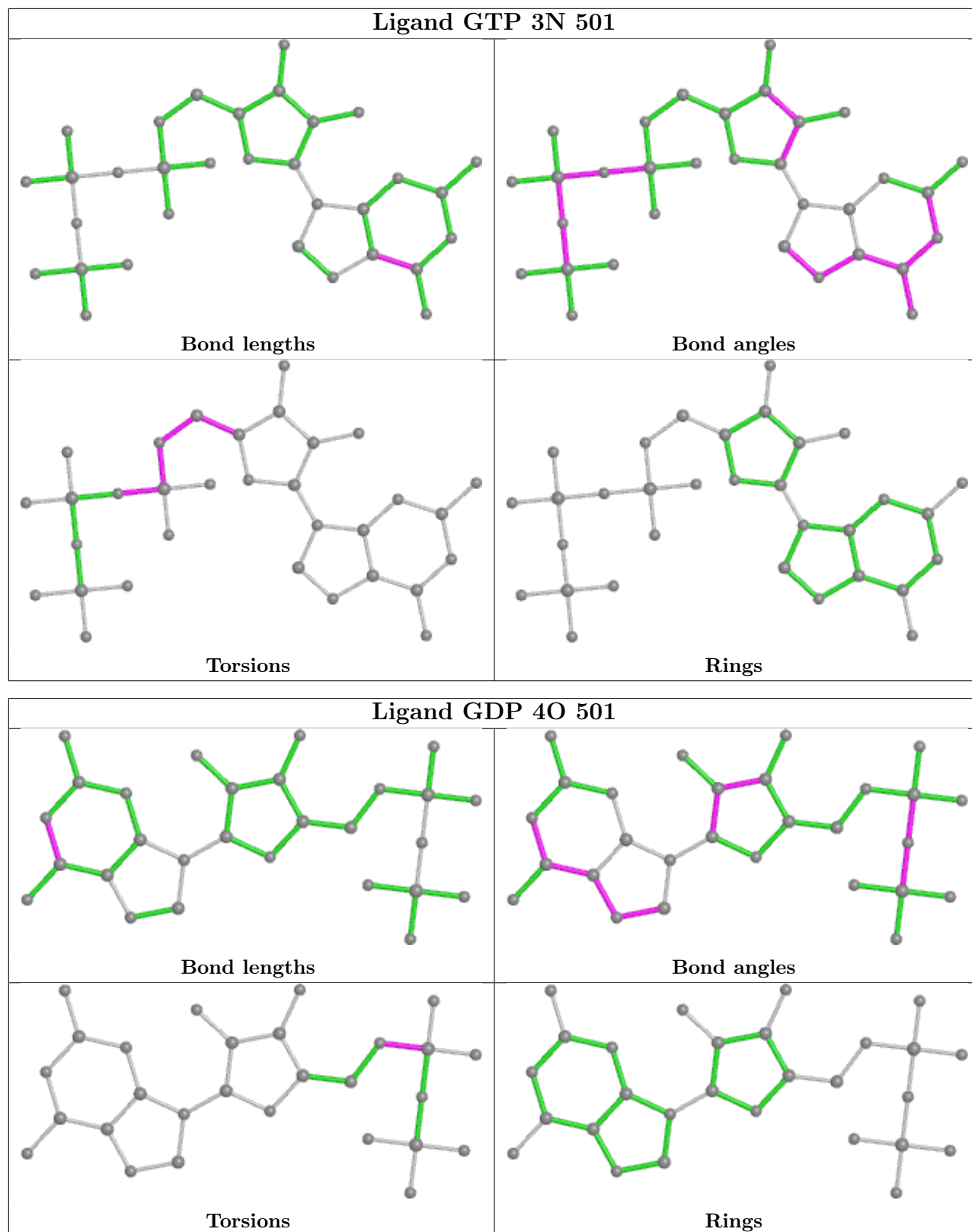

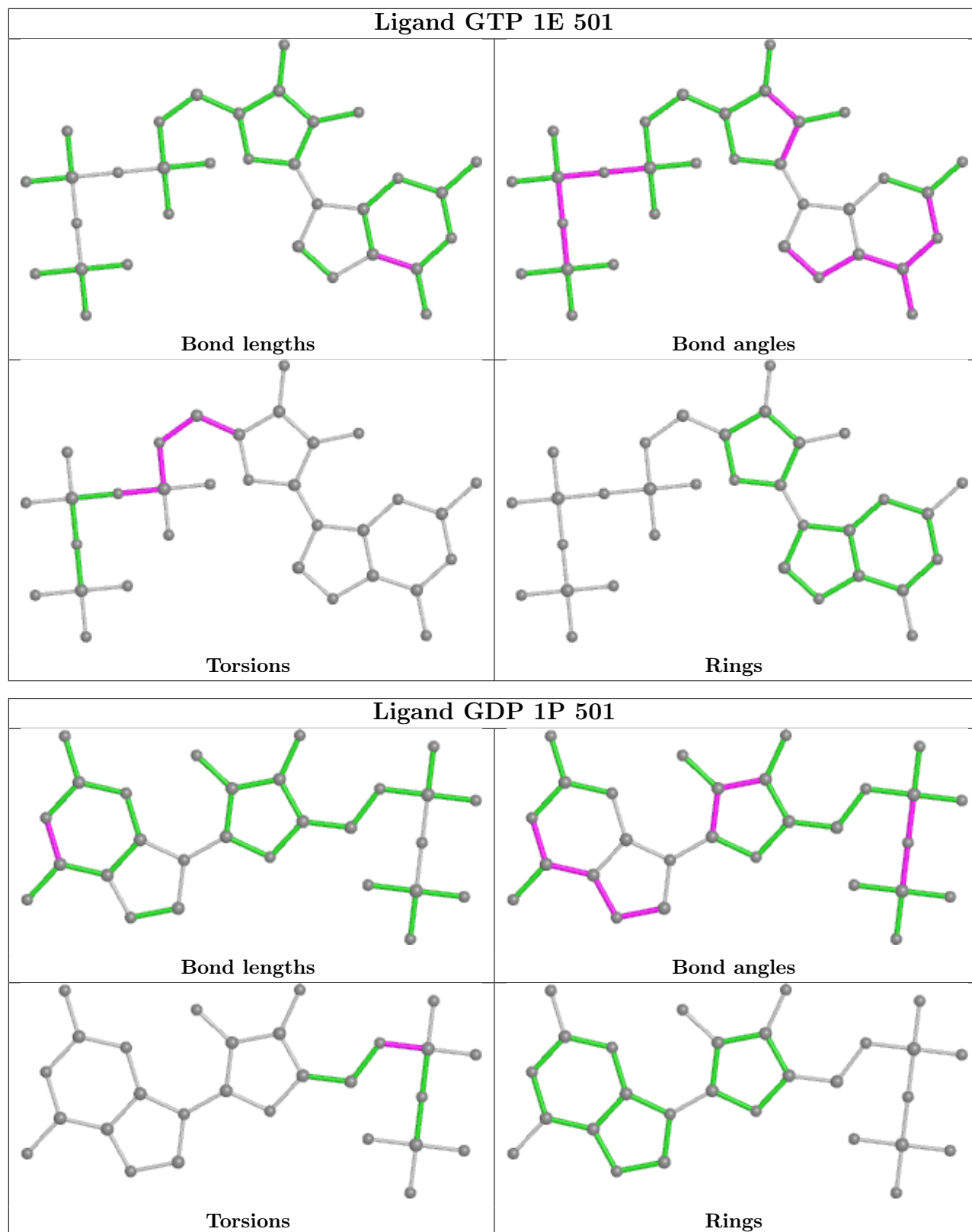

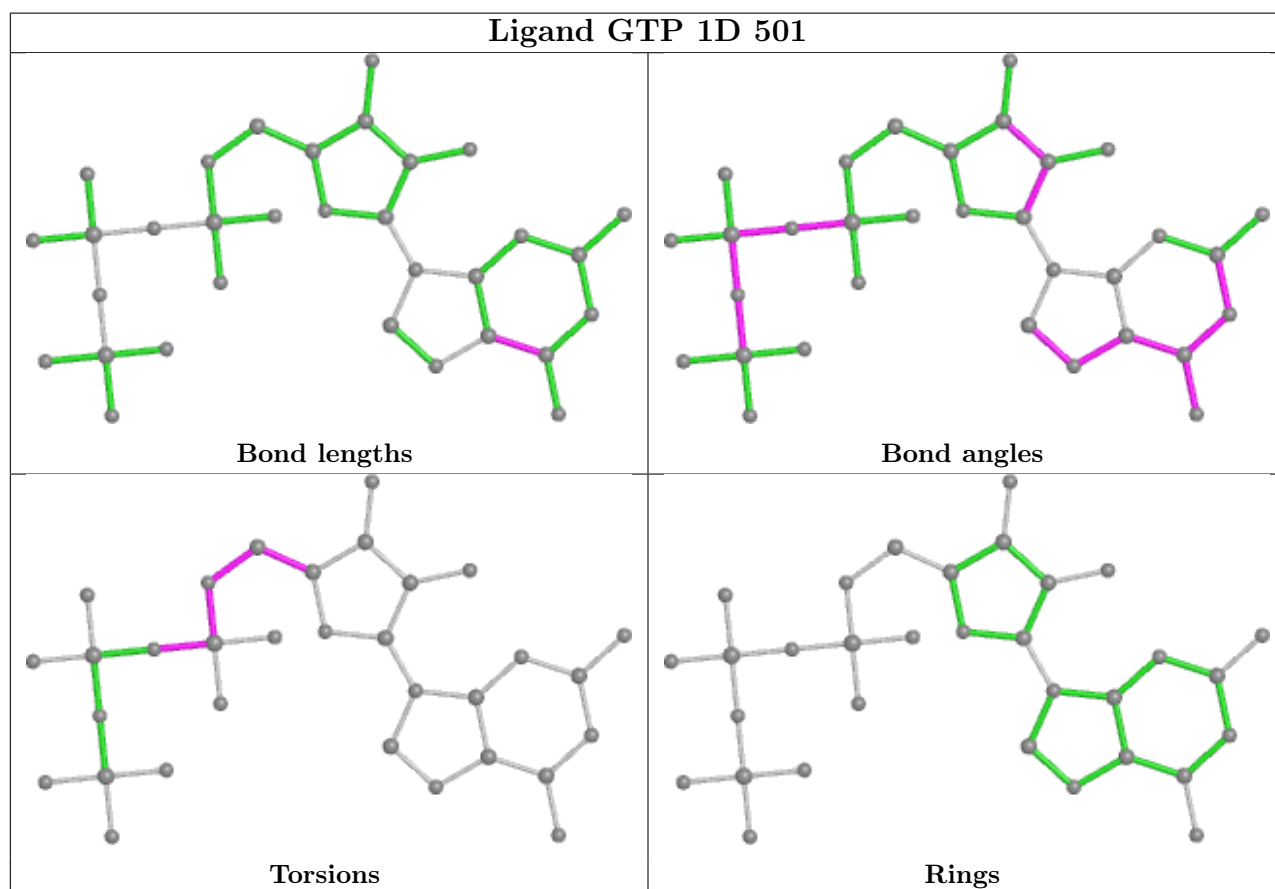
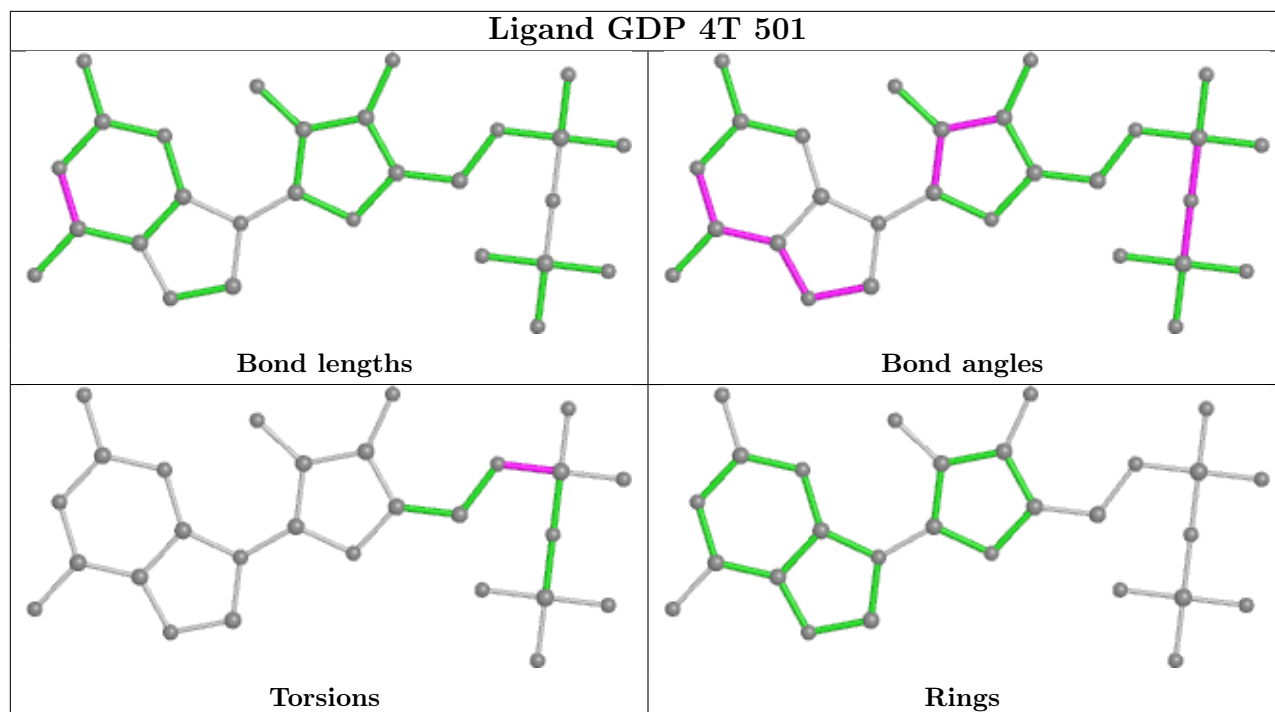

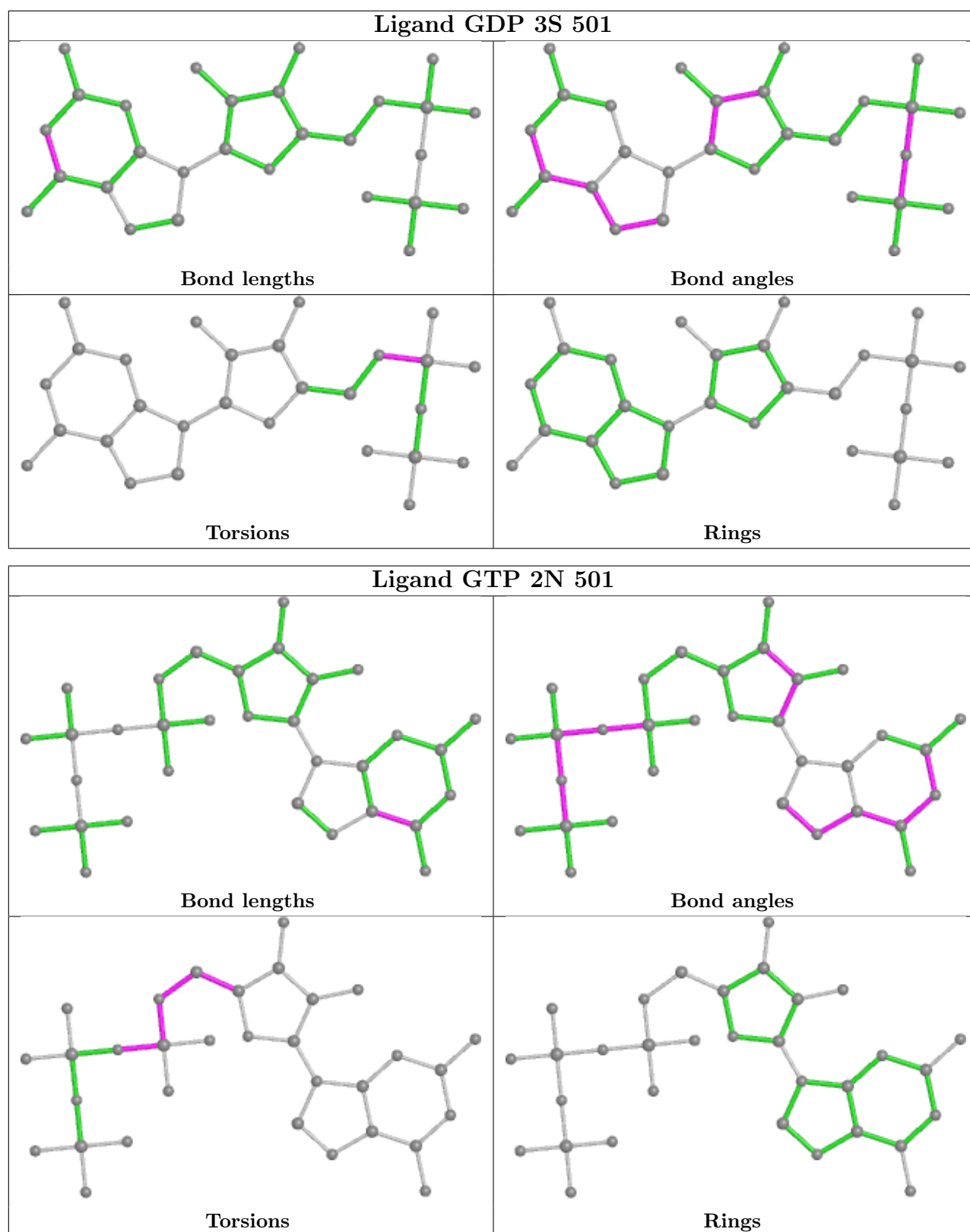

5.7 Other polymers [i](#)

There are no such residues in this entry.

5.8 Polymer linkage issues

There are no chain breaks in this entry.

6 Map visualisation [i](#)

This section contains visualisations of the EMDB entry EMD-0614. These allow visual inspection of the internal detail of the map and identification of artifacts.

Images derived from a raw map, generated by summing the deposited half-maps, are presented below the corresponding image components of the primary map to allow further visual inspection and comparison with those of the primary map.

6.1 Orthogonal projections [i](#)

6.1.1 Primary map

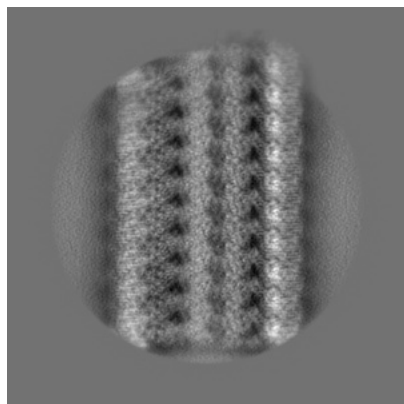

X

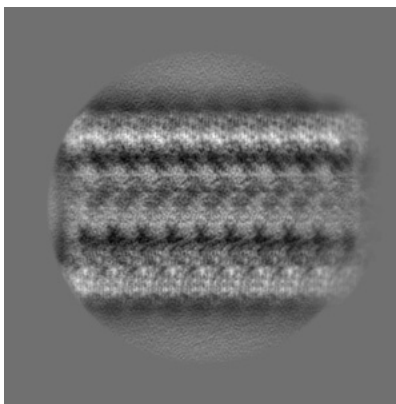

Y

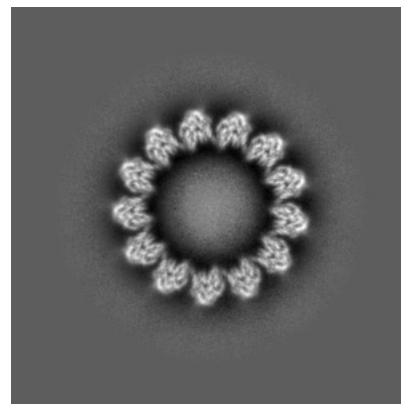

Z

6.1.2 Raw map

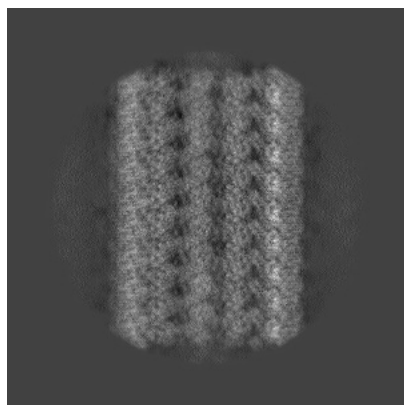

X

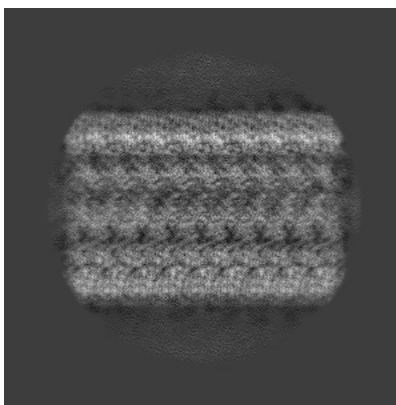

Y

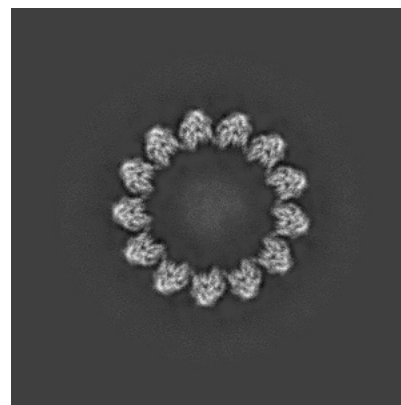

Z

The images above show the map projected in three orthogonal directions.

6.2 Central slices [i](#)

6.2.1 Primary map

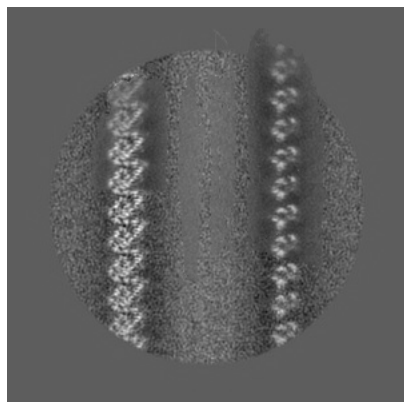

X Index: 256

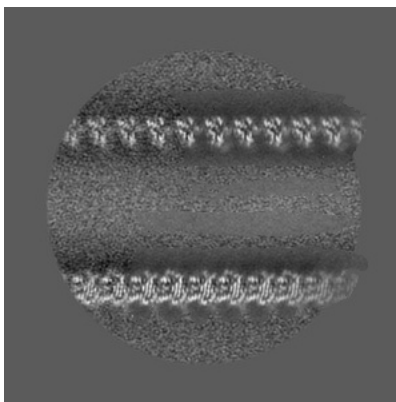

Y Index: 256

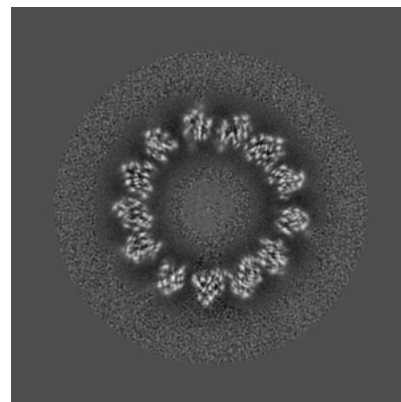

Z Index: 256

6.2.2 Raw map

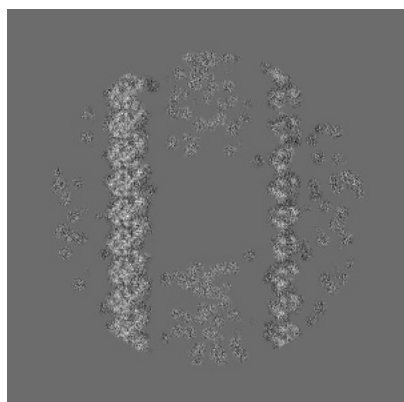

X Index: 256

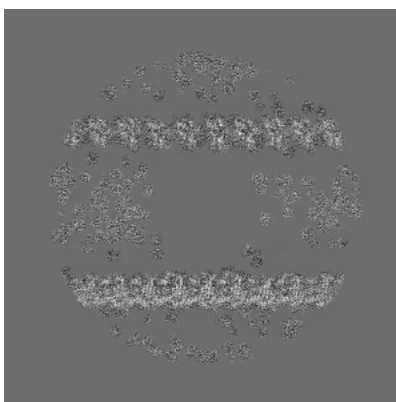

Y Index: 256

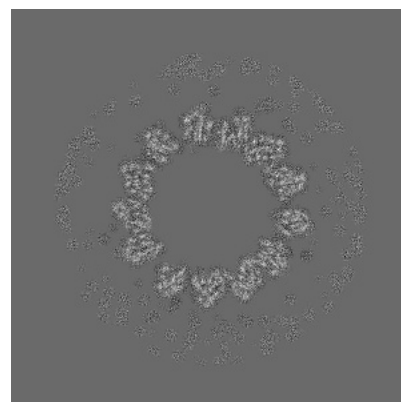

Z Index: 256

The images above show central slices of the map in three orthogonal directions.

6.3 Largest variance slices [i](#)

6.3.1 Primary map

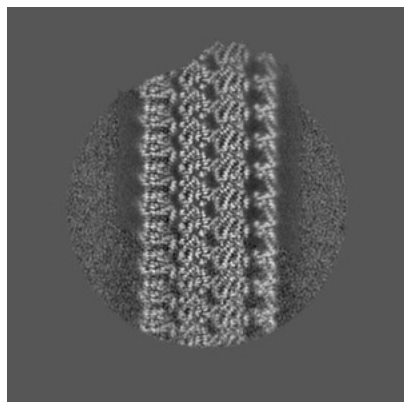

X Index: 346

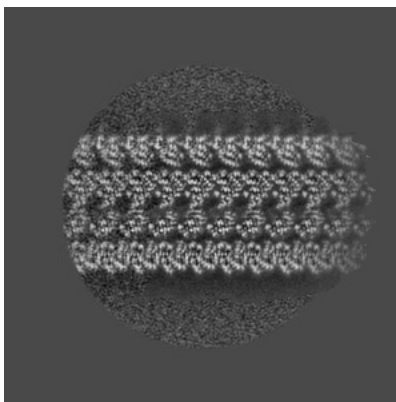

Y Index: 343

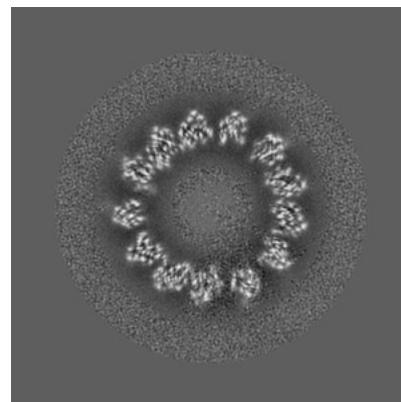

Z Index: 235

6.3.2 Raw map

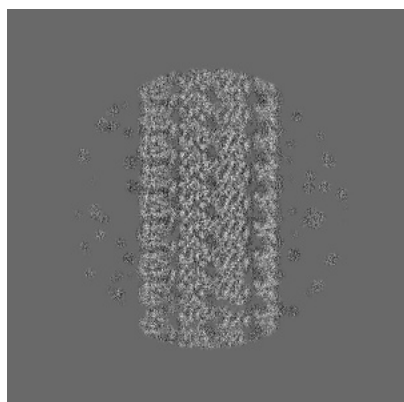

X Index: 346

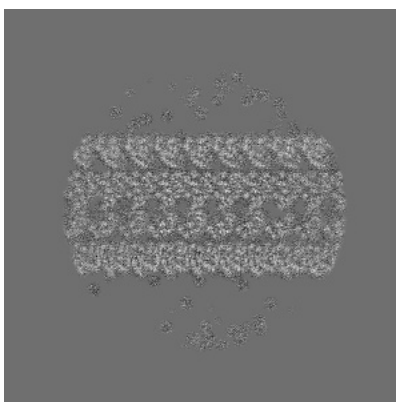

Y Index: 343

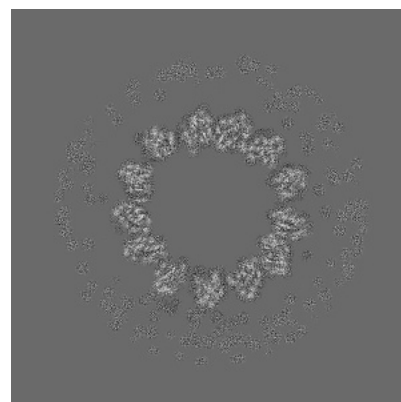

Z Index: 249

The images above show the largest variance slices of the map in three orthogonal directions.

6.4 Orthogonal standard-deviation projections (False-color) [i](#)

6.4.1 Primary map

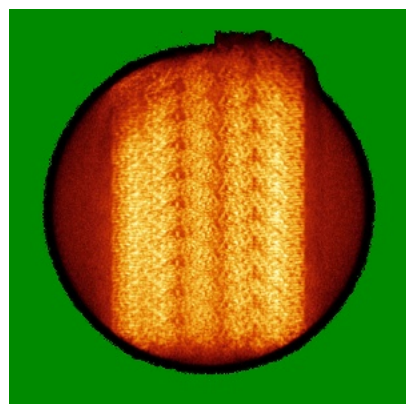

X

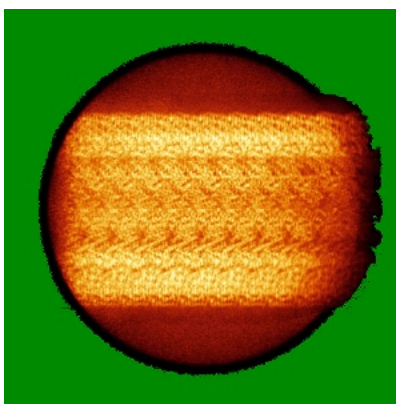

Y

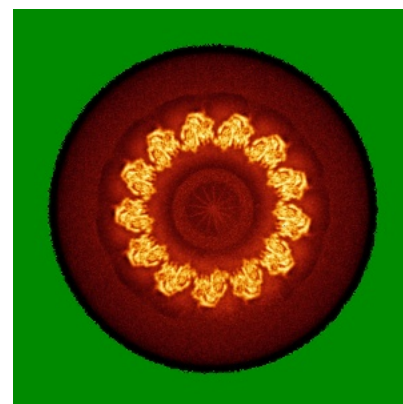

Z

6.4.2 Raw map

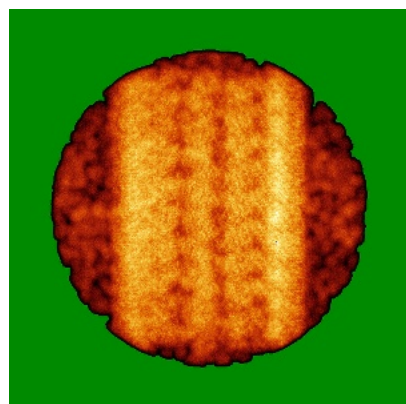

X

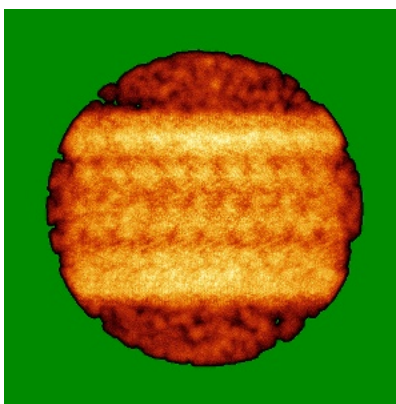

Y

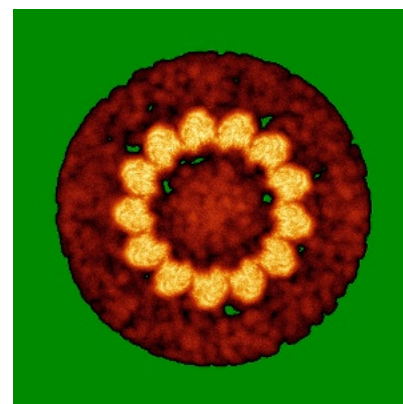

Z

The images above show the map standard deviation projections with false color in three orthogonal directions. Minimum values are shown in green, max in blue, and dark to light orange shades represent small to large values respectively.

6.5 Orthogonal surface views [i](#)

6.5.1 Primary map

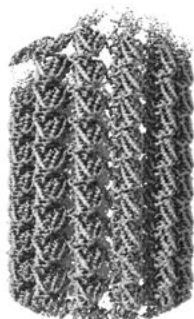

X



Y

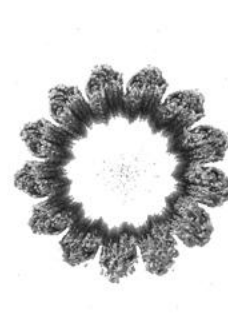

Z

The images above show the 3D surface view of the map at the recommended contour level 4.0. These images, in conjunction with the slice images, may facilitate assessment of whether an appropriate contour level has been provided.

6.5.2 Raw map

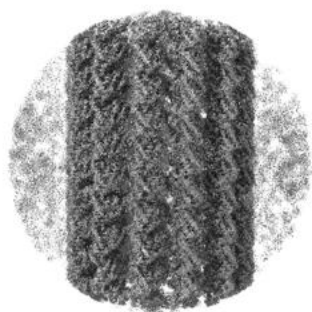

X

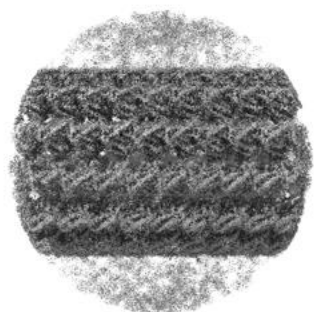

Y

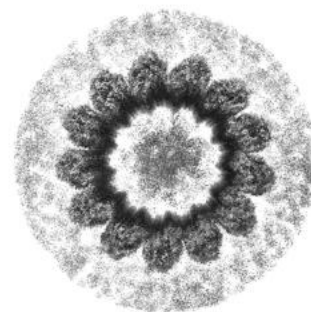

Z

These images show the 3D surface of the raw map. The raw map's contour level was selected so that its surface encloses the same volume as the primary map does at its recommended contour level.

6.6 Mask visualisation [i](#)

This section was not generated. No masks/segmentation were deposited.

7 Map analysis [i](#)

This section contains the results of statistical analysis of the map.

7.1 Map-value distribution [i](#)

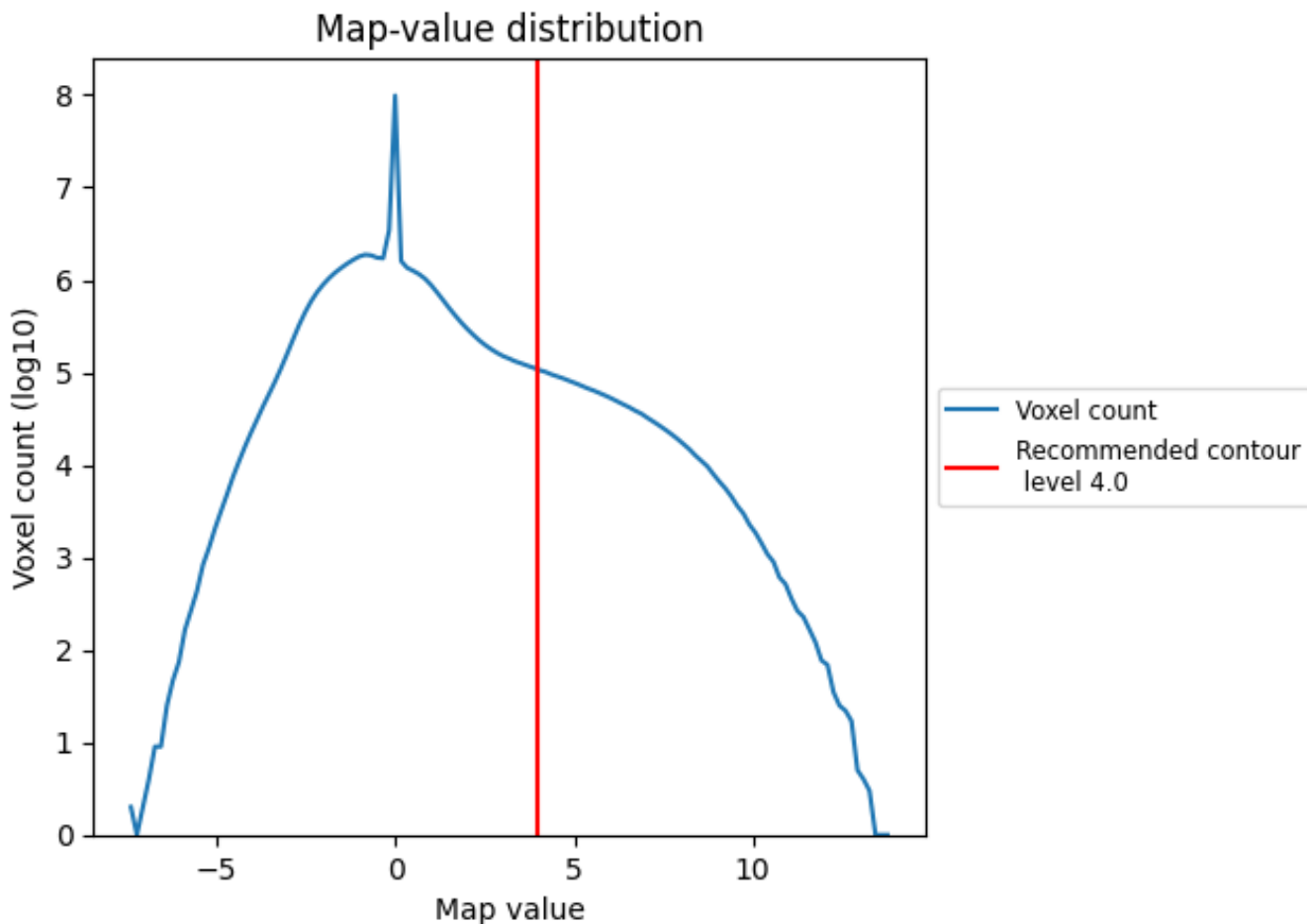

The map-value distribution is plotted in 128 intervals along the x-axis. The y-axis is logarithmic. A spike in this graph at zero usually indicates that the volume has been masked.

7.2 Volume estimate [\(i\)](#)

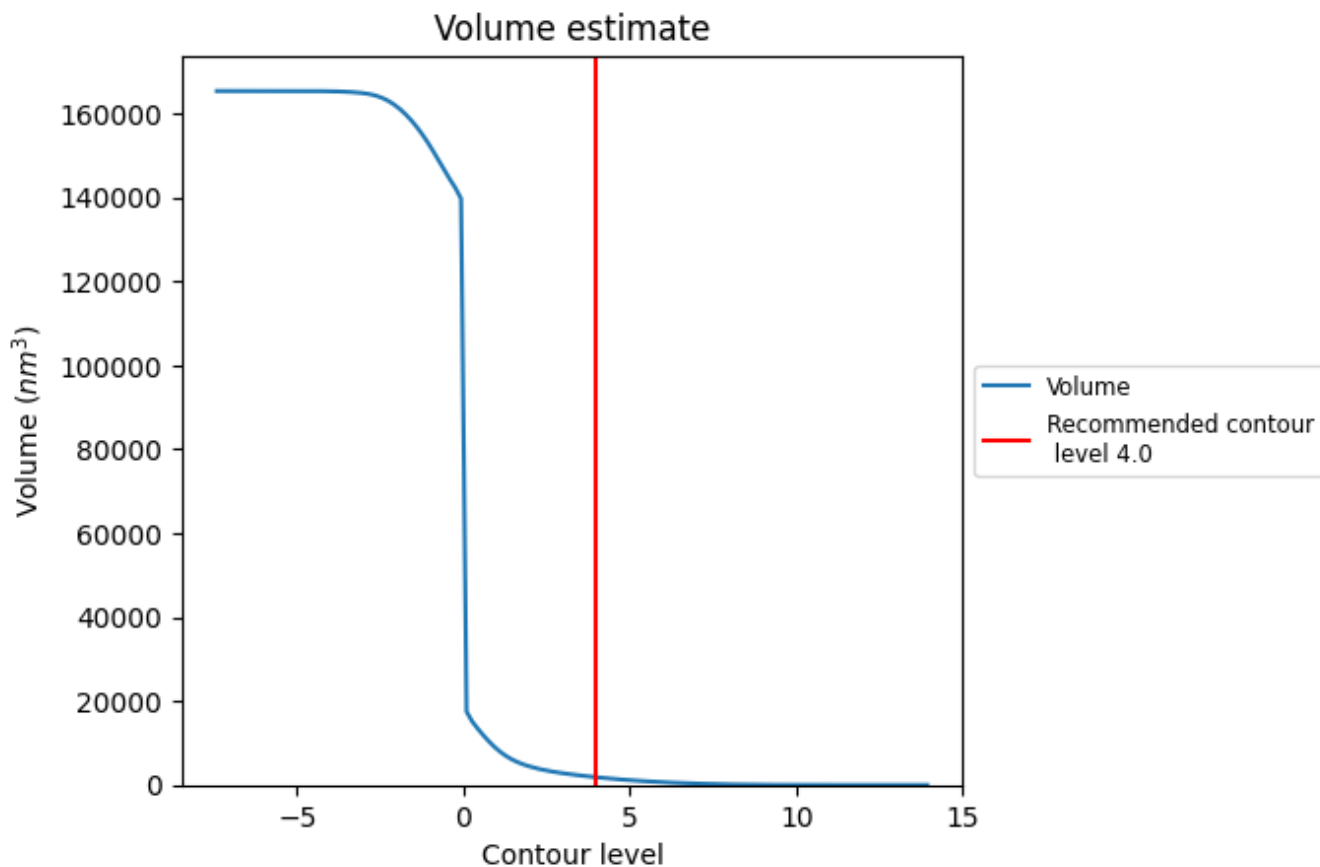

The volume at the recommended contour level is 1830 nm^3 ; this corresponds to an approximate mass of 1653 kDa.

The volume estimate graph shows how the enclosed volume varies with the contour level. The recommended contour level is shown as a vertical line and the intersection between the line and the curve gives the volume of the enclosed surface at the given level.

7.3 Rotationally averaged power spectrum i

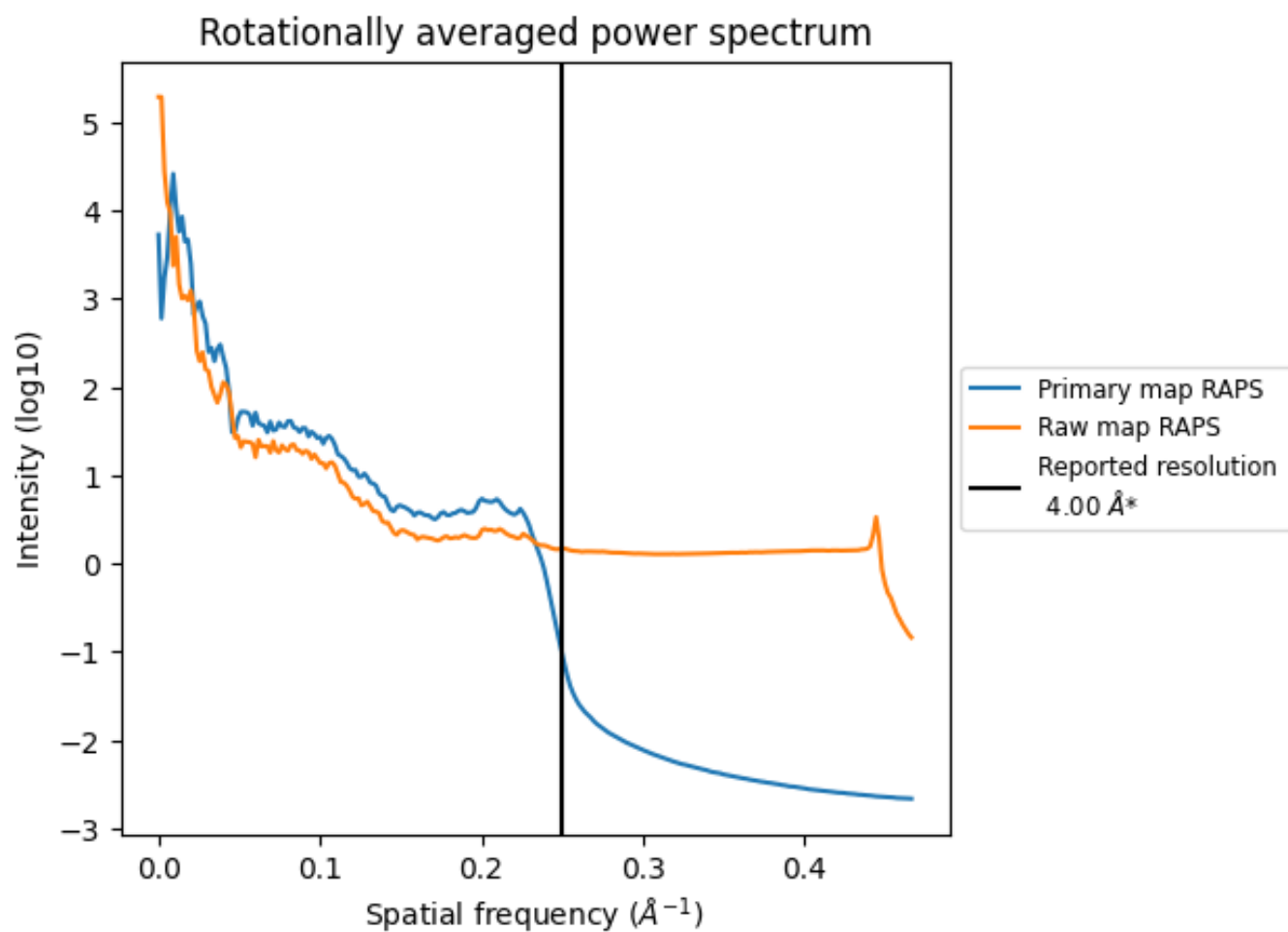

*Reported resolution corresponds to spatial frequency of 0.250 \AA^{-1}

8 Fourier-Shell correlation [i](#)

Fourier-Shell Correlation (FSC) is the most commonly used method to estimate the resolution of single-particle and subtomogram-averaged maps. The shape of the curve depends on the imposed symmetry, mask and whether or not the two 3D reconstructions used were processed from a common reference. The reported resolution is shown as a black line. A curve is displayed for the half-bit criterion in addition to lines showing the 0.143 gold standard cut-off and 0.5 cut-off.

8.1 FSC [i](#)

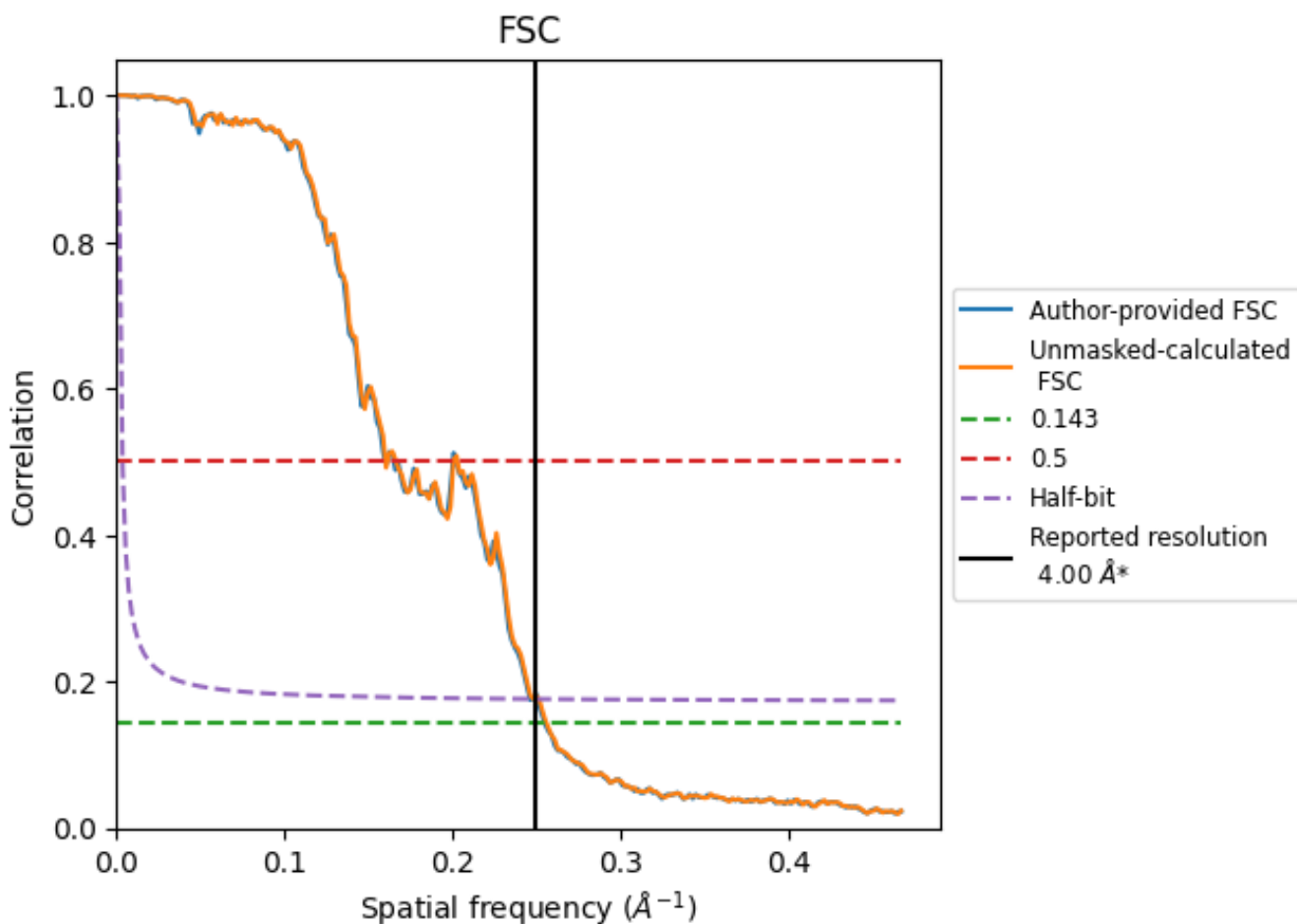

*Reported resolution corresponds to spatial frequency of 0.250 Å⁻¹

8.2 Resolution estimates [i](#)

Resolution estimate (Å)	Estimation criterion (FSC cut-off)		
	0.143	0.5	Half-bit
Reported by author	4.00	-	-
Author-provided FSC curve	3.92	6.24	4.06
Unmasked-calculated*	3.90	6.24	4.03

*Resolution estimate based on FSC curve calculated by comparison of deposited half-maps.

9 Map-model fit [i](#)

This section contains information regarding the fit between EMDB map EMD-0614 and PDB model 6O2S. Per-residue inclusion information can be found in section 3 on page 21.

9.1 Map-model overlay [i](#)

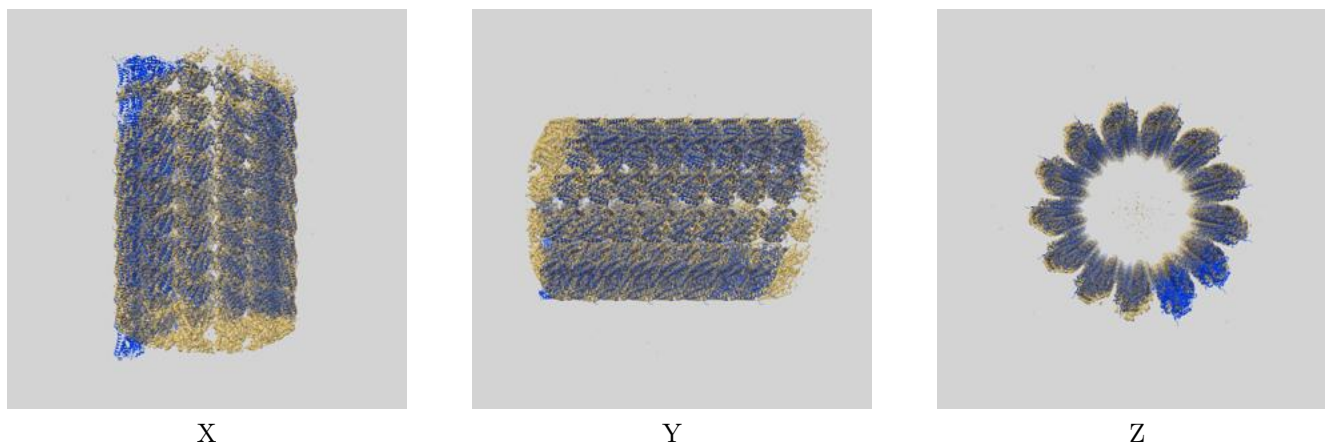

The images above show the 3D surface view of the map at the recommended contour level 4.0 at 50% transparency in yellow overlaid with a ribbon representation of the model coloured in blue. These images allow for the visual assessment of the quality of fit between the atomic model and the map.

9.2 Q-score mapped to coordinate model [i](#)

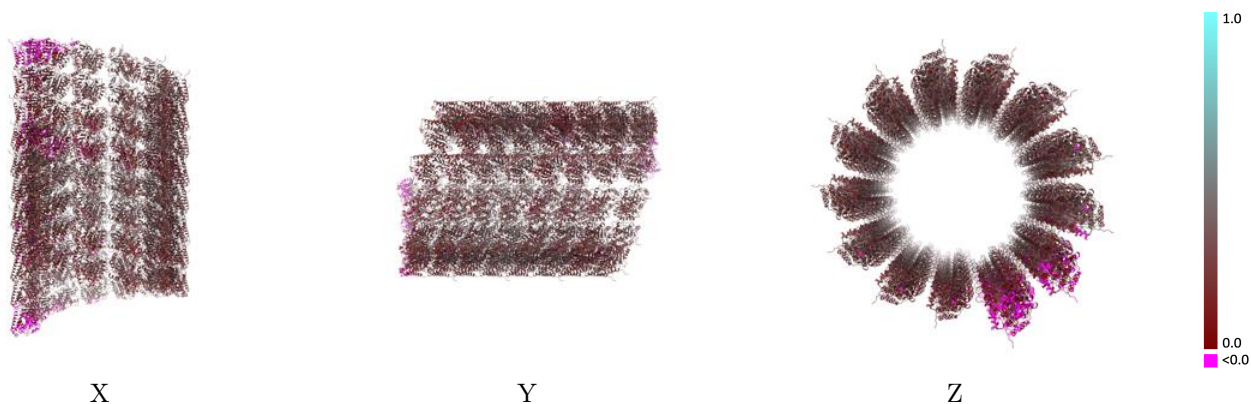

The images above show the model with each residue coloured according to its Q-score. This shows their resolvability in the map with higher Q-score values reflecting better resolvability. Please note: Q-score is calculating the resolvability of atoms, and thus high values are only expected at resolutions at which atoms can be resolved. Low Q-score values may therefore be expected for many entries.

9.3 Atom inclusion mapped to coordinate model [i](#)

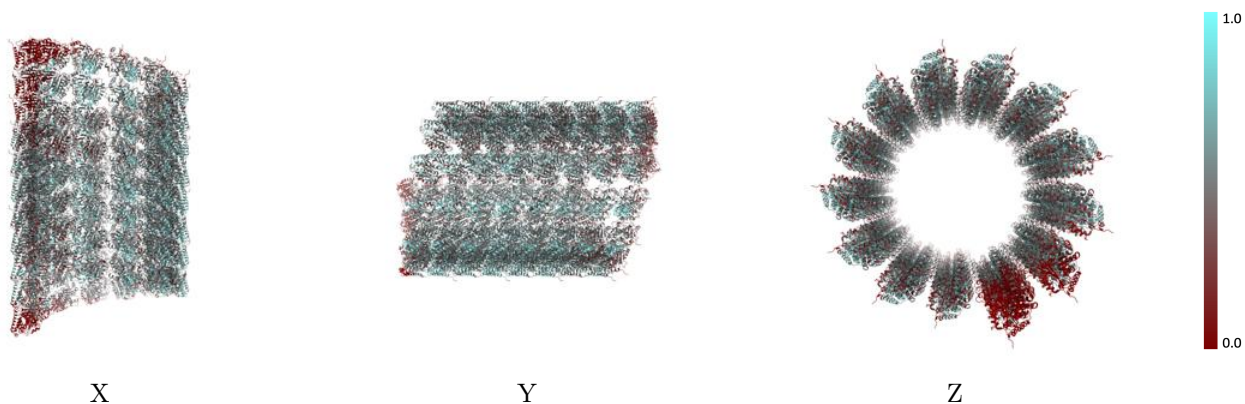

The images above show the model with each residue coloured according to its atom inclusion. This shows to what extent they are inside the map at the recommended contour level (4.0).



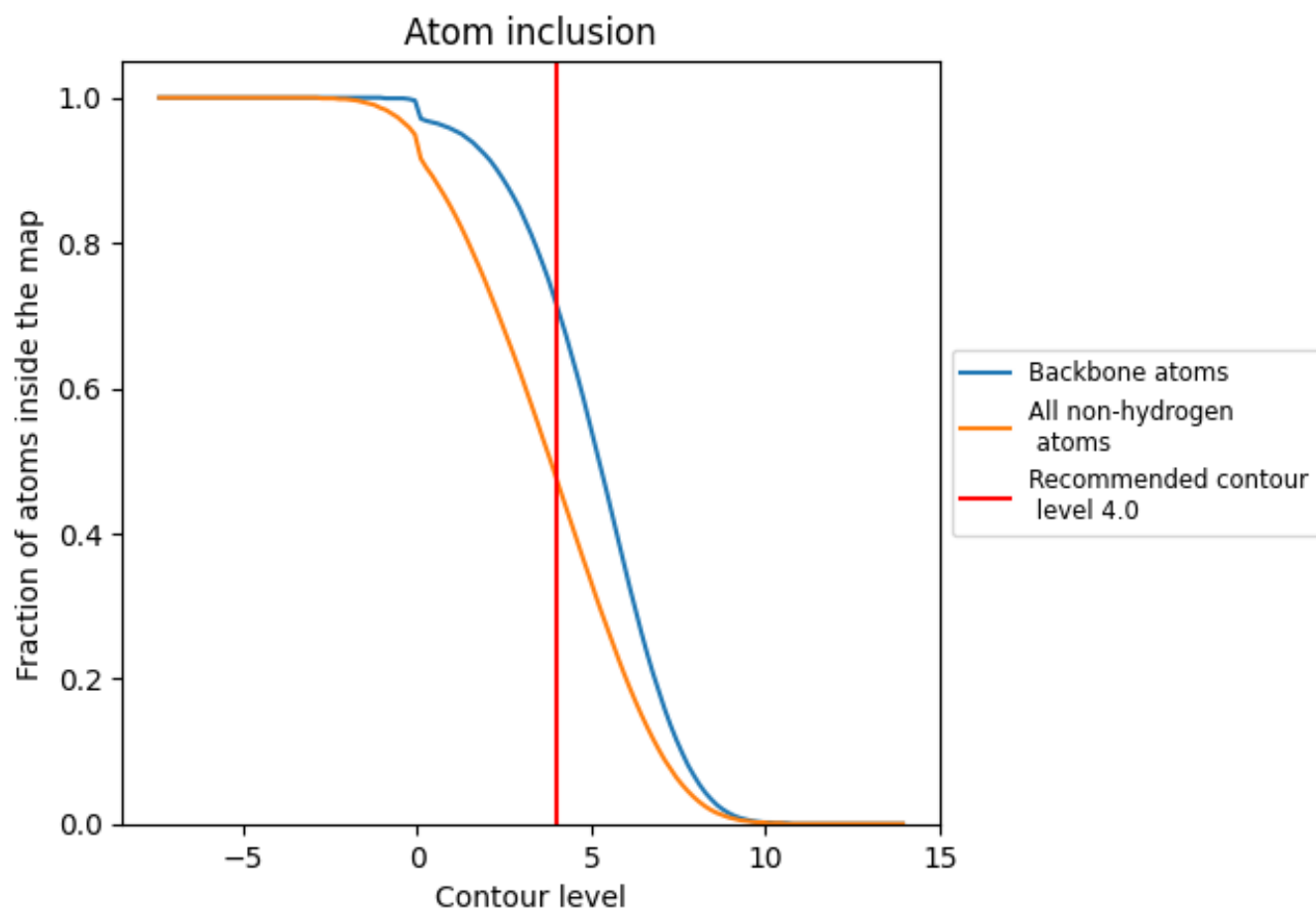



































































9.4 Atom inclusion [i](#)



At the recommended contour level, 71% of all backbone atoms, 47% of all non-hydrogen atoms, are inside the map.

9.5 Map-model fit summary

The table lists the average atom inclusion at the recommended contour level (4.0) and Q-score for the entire model and for each chain.

Chain	Atom inclusion	Q-score
All	 0.4740	 0.2750
1A	 0.5560	 0.3520
1B	 0.5580	 0.3460
1C	 0.5540	 0.3330
1D	 0.5470	 0.3300
1E	 0.5410	 0.3140
1F	 0.5240	 0.2940
1G	 0.5270	 0.2920
1H	 0.5700	 0.3370
1I	 0.5230	 0.2960
1J	 0.5070	 0.2720
1K	 0.4850	 0.2380
1L	 0.4860	 0.2480
1M	 0.1460	 0.1830
1N	 0.5290	 0.3160
1O	 0.5660	 0.3350
1P	 0.5670	 0.3350
1Q	 0.5660	 0.3280
1R	 0.5400	 0.2860
1S	 0.5140	 0.2590
1T	 0.5000	 0.2440
1U	 0.4900	 0.2290
1V	 0.4910	 0.2200
1W	 0.4410	 0.1750
1X	 0.4070	 0.1420
1Y	 0.3310	 0.1110
1Z	 0.5350	 0.2920
2A	 0.5520	 0.3260
2B	 0.5720	 0.3560
2C	 0.5700	 0.3550
2D	 0.5660	 0.3490
2E	 0.5690	 0.3530
2F	 0.5550	 0.3340
2G	 0.5510	 0.3320
2H	 0.5130	 0.2680



Continued on next page...

Continued from previous page...

Chain	Atom inclusion	Q-score
2I	0.5480	0.3290
2J	0.5380	0.3320
2K	0.5560	0.3380
2L	0.5590	0.3250
2M	0.5500	0.3270
2N	0.4790	0.2650
2O	0.5420	0.3050
2P	0.5310	0.2880
2Q	0.5510	0.3150
2R	0.5480	0.3120
2S	0.5420	0.2990
2T	0.5450	0.3130
2U	0.5430	0.3150
2V	0.5430	0.3140
2W	0.5480	0.3190
2X	0.5230	0.2930
2Y	0.4780	0.2380
2Z	0.4770	0.2550
3A	0.4750	0.2720
3B	0.4740	0.2970
3C	0.4900	0.2970
3D	0.5170	0.2920
3E	0.5210	0.2800
3F	0.5100	0.2690
3G	0.5020	0.2690
3H	0.1860	0.1350
3I	0.4910	0.2600
3J	0.5040	0.2610
3K	0.5150	0.2560
3L	0.4890	0.2520
3M	0.4680	0.2310
3N	0.3710	0.2230
3O	0.2760	0.1950
3P	0.3650	0.2270
3Q	0.4480	0.2510
3R	0.4870	0.2690
3S	0.4840	0.2730
3T	0.4860	0.2780
3U	0.5040	0.2900
3V	0.5030	0.2790
3W	0.5000	0.2660
3X	0.4480	0.2460

Continued on next page...

Continued from previous page...

Chain	Atom inclusion	Q-score
3Y	■ 0.3970	■ 0.1780
3Z	■ 0.0900	■ 0.0640
4A	■ 0.4020	■ 0.2560
4B	■ 0.4410	■ 0.3080
4C	■ 0.4350	■ 0.2990
4D	■ 0.4300	■ 0.2990
4E	■ 0.4430	■ 0.3160
4F	■ 0.4420	■ 0.3240
4G	■ 0.4400	■ 0.3160
4H	■ 0.4840	■ 0.2570
4I	■ 0.4430	■ 0.3230
4J	■ 0.4330	■ 0.3250
4K	■ 0.4040	■ 0.3160
4L	■ 0.1600	■ 0.1270
4M	■ 0.0430	■ 0.0440
4N	■ 0.3570	■ 0.2180
4O	■ 0.4920	■ 0.2630
4P	■ 0.4860	■ 0.2650
4Q	■ 0.4790	■ 0.2580
4R	■ 0.4850	■ 0.2720
4S	■ 0.4970	■ 0.2950
4T	■ 0.4900	■ 0.2880
4U	■ 0.4890	■ 0.2820
4V	■ 0.5080	■ 0.3210
4W	■ 0.5150	■ 0.3160
4X	■ 0.4180	■ 0.2730
4Y	■ 0.0730	■ 0.1820
4Z	■ 0.4640	■ 0.2260