



Full wwPDB X-ray Structure Validation Report ⓘ

Aug 20, 2023 – 10:07 AM EDT

PDB ID : 2NXI
Title : Structural and mechanistic changes along an engineered path from metallo to non-metallo KDO8P synthase.
Authors : Kona, F.; Xu, X.; Martin, P.; Kuzmic, P.; Gatti, D.L.
Deposited on : 2006-11-17
Resolution : 2.30 Å(reported)

This is a Full wwPDB X-ray Structure Validation Report for a publicly released PDB entry.

We welcome your comments at validation@mail.wwpdb.org

A user guide is available at

<https://www.wwpdb.org/validation/2017/XrayValidationReportHelp>

with specific help available everywhere you see the ⓘ symbol.

The types of validation reports are described at

<http://www.wwpdb.org/validation/2017/FAQs#types>.

The following versions of software and data (see [references ⓘ](#)) were used in the production of this report:

MolProbity : 4.02b-467
Mogul : 1.8.5 (274361), CSD as541be (2020)
Xtriage (Phenix) : 1.13
EDS : 2.35
Percentile statistics : 20191225.v01 (using entries in the PDB archive December 25th 2019)
Refmac : 5.8.0158
CCP4 : 7.0.044 (Gargrove)
Ideal geometry (proteins) : Engh & Huber (2001)
Ideal geometry (DNA, RNA) : Parkinson et al. (1996)
Validation Pipeline (wwPDB-VP) : 2.35

1 Overall quality at a glance i

The following experimental techniques were used to determine the structure:

X-RAY DIFFRACTION

The reported resolution of this entry is 2.30 Å.

Percentile scores (ranging between 0-100) for global validation metrics of the entry are shown in the following graphic. The table shows the number of entries on which the scores are based.

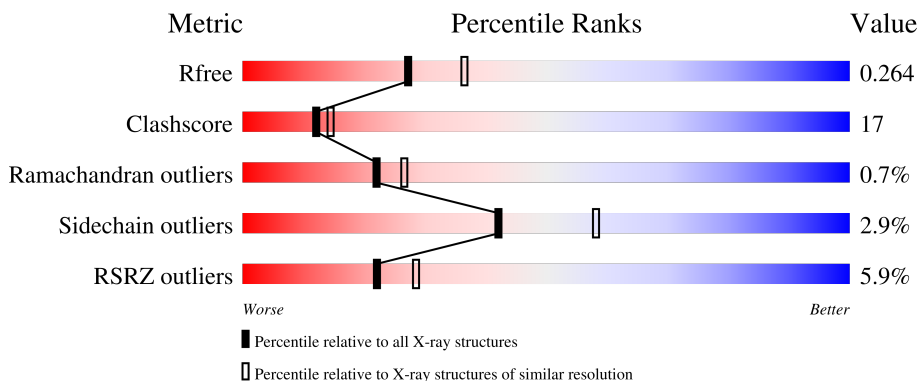

Metric	Whole archive (#Entries)	Similar resolution (#Entries, resolution range(Å))
R_{free}	130704	5042 (2.30-2.30)
Clashscore	141614	5643 (2.30-2.30)
Ramachandran outliers	138981	5575 (2.30-2.30)
Sidechain outliers	138945	5575 (2.30-2.30)
RSRZ outliers	127900	4938 (2.30-2.30)

The table below summarises the geometric issues observed across the polymeric chains and their fit to the electron density. The red, orange, yellow and green segments of the lower bar indicate the fraction of residues that contain outliers for ≥ 3 , 2, 1 and 0 types of geometric quality criteria respectively. A grey segment represents the fraction of residues that are not modelled. The numeric value for each fraction is indicated below the corresponding segment, with a dot representing fractions $\leq 5\%$. The upper red bar (where present) indicates the fraction of residues that have poor fit to the electron density. The numeric value is given above the bar.

Mol	Chain	Length	Quality of chain
1	A	263	<div style="display: flex; align-items: center;"> <div style="width: 2%; height: 10px; background-color: red; margin-right: 2px;"></div> <div style="width: 71%; height: 10px; background-color: green; margin-right: 2px;"></div> <div style="width: 25%; height: 10px; background-color: yellow; margin-right: 2px;"></div> <div style="width: 2%; height: 10px; background-color: grey; margin-right: 2px;"></div> <div style="width: 2%; height: 10px; background-color: grey;"></div> </div> <p style="text-align: center;">2% 71% 25% ..</p>
1	B	263	<div style="display: flex; align-items: center;"> <div style="width: 2%; height: 10px; background-color: red; margin-right: 2px;"></div> <div style="width: 75%; height: 10px; background-color: green; margin-right: 2px;"></div> <div style="width: 22%; height: 10px; background-color: yellow; margin-right: 2px;"></div> <div style="width: 2%; height: 10px; background-color: grey; margin-right: 2px;"></div> <div style="width: 2%; height: 10px; background-color: grey;"></div> </div> <p style="text-align: center;">2% 75% 22% ..</p>
1	C	263	<div style="display: flex; align-items: center;"> <div style="width: 3%; height: 10px; background-color: red; margin-right: 2px;"></div> <div style="width: 63%; height: 10px; background-color: green; margin-right: 2px;"></div> <div style="width: 32%; height: 10px; background-color: yellow; margin-right: 2px;"></div> <div style="width: 2%; height: 10px; background-color: grey; margin-right: 2px;"></div> <div style="width: 2%; height: 10px; background-color: grey;"></div> </div> <p style="text-align: center;">3% 63% 32% ..</p>
1	D	263	<div style="display: flex; align-items: center;"> <div style="width: 6%; height: 10px; background-color: red; margin-right: 2px;"></div> <div style="width: 58%; height: 10px; background-color: green; margin-right: 2px;"></div> <div style="width: 37%; height: 10px; background-color: yellow; margin-right: 2px;"></div> <div style="width: 2%; height: 10px; background-color: grey; margin-right: 2px;"></div> <div style="width: 2%; height: 10px; background-color: grey;"></div> </div> <p style="text-align: center;">6% 58% 37% ..</p>
1	E	263	<div style="display: flex; align-items: center;"> <div style="width: 11%; height: 10px; background-color: red; margin-right: 2px;"></div> <div style="width: 59%; height: 10px; background-color: green; margin-right: 2px;"></div> <div style="width: 36%; height: 10px; background-color: yellow; margin-right: 2px;"></div> <div style="width: 2%; height: 10px; background-color: grey; margin-right: 2px;"></div> <div style="width: 2%; height: 10px; background-color: grey;"></div> </div> <p style="text-align: center;">11% 59% 36% ..</p>

Continued on next page...

Continued from previous page...

Mol	Chain	Length	Quality of chain
1	F	263	
1	G	263	
1	H	263	
1	I	263	
1	J	263	
1	K	263	
1	L	263	

2 Entry composition

There are 4 unique types of molecules in this entry. The entry contains 25761 atoms, of which 0 are hydrogens and 0 are deuteriums.

In the tables below, the ZeroOcc column contains the number of atoms modelled with zero occupancy, the AltConf column contains the number of residues with at least one atom in alternate conformation and the Trace column contains the number of residues modelled with at most 2 atoms.

- Molecule 1 is a protein called 2-dehydro-3-deoxyphosphooctonate aldolase.

Mol	Chain	Residues	Atoms					ZeroOcc	AltConf	Trace
			Total	C	N	O	S			
1	A	257	Total 2029	C 1310	N 339	O 374	S 6	0	0	0
1	B	258	Total 2033	C 1312	N 340	O 375	S 6	0	0	0
1	C	257	Total 2025	C 1306	N 339	O 374	S 6	0	0	0
1	D	256	Total 2021	C 1304	N 338	O 373	S 6	0	0	0
1	E	256	Total 2021	C 1304	N 338	O 373	S 6	0	0	0
1	F	255	Total 2017	C 1302	N 337	O 372	S 6	0	0	0
1	G	259	Total 2041	C 1316	N 341	O 378	S 6	0	0	0
1	H	256	Total 2021	C 1304	N 338	O 373	S 6	0	0	0
1	I	262	Total 2060	C 1327	N 345	O 382	S 6	0	0	0
1	J	262	Total 2060	C 1327	N 345	O 382	S 6	0	0	0
1	K	257	Total 2029	C 1310	N 339	O 374	S 6	0	0	0
1	L	256	Total 2021	C 1304	N 338	O 373	S 6	0	0	0

There are 24 discrepancies between the modelled and reference sequences:

Chain	Residue	Modelled	Actual	Comment	Reference
A	10	MET	PRO	engineered mutation	UNP O66496
A	11	ASN	CYS	engineered mutation	UNP O66496
B	10	MET	PRO	engineered mutation	UNP O66496
B	11	ASN	CYS	engineered mutation	UNP O66496
C	10	MET	PRO	engineered mutation	UNP O66496

Continued on next page...

Continued from previous page...

Chain	Residue	Modelled	Actual	Comment	Reference
C	11	ASN	CYS	engineered mutation	UNP O66496
D	10	MET	PRO	engineered mutation	UNP O66496
D	11	ASN	CYS	engineered mutation	UNP O66496
E	10	MET	PRO	engineered mutation	UNP O66496
E	11	ASN	CYS	engineered mutation	UNP O66496
F	10	MET	PRO	engineered mutation	UNP O66496
F	11	ASN	CYS	engineered mutation	UNP O66496
G	10	MET	PRO	engineered mutation	UNP O66496
G	11	ASN	CYS	engineered mutation	UNP O66496
H	10	MET	PRO	engineered mutation	UNP O66496
H	11	ASN	CYS	engineered mutation	UNP O66496
I	10	MET	PRO	engineered mutation	UNP O66496
I	11	ASN	CYS	engineered mutation	UNP O66496
J	10	MET	PRO	engineered mutation	UNP O66496
J	11	ASN	CYS	engineered mutation	UNP O66496
K	10	MET	PRO	engineered mutation	UNP O66496
K	11	ASN	CYS	engineered mutation	UNP O66496
L	10	MET	PRO	engineered mutation	UNP O66496
L	11	ASN	CYS	engineered mutation	UNP O66496

- Molecule 2 is PHOSPHATE ION (three-letter code: PO4) (formula: O₄P).



Mol	Chain	Residues	Atoms	ZeroOcc	AltConf		
2	A	1	Total	O	P	0	0
			5	4	1		
2	D	1	Total	O	P	0	0
			5	4	1		

Continued on next page...

Continued from previous page...

Mol	Chain	Residues	Atoms			ZeroOcc	AltConf
2	E	1	Total	O	P	0	0
			5	4	1		
2	F	1	Total	O	P	0	0
			5	4	1		
2	J	1	Total	O	P	0	0
			5	4	1		
2	K	1	Total	O	P	0	0
			5	4	1		
2	L	1	Total	O	P	0	0
			5	4	1		

- Molecule 3 is PHOSPHOENOLPYRUVATE (three-letter code: PEP) (formula: $C_3H_5O_6P$).

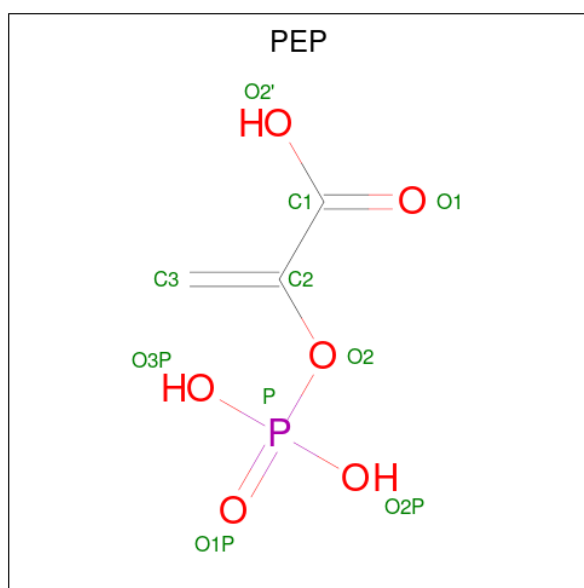

Mol	Chain	Residues	Atoms				ZeroOcc	AltConf
3	A	1	Total	C	O	P	0	0
			10	3	6	1		
3	B	1	Total	C	O	P	0	0
			10	3	6	1		
3	B	1	Total	C	O	P	0	0
			10	3	6	1		
3	C	1	Total	C	O	P	0	0
			10	3	6	1		
3	C	1	Total	C	O	P	0	0
			10	3	6	1		
3	D	1	Total	C	O	P	0	0
			10	3	6	1		

Continued on next page...

Continued from previous page...

Mol	Chain	Residues	Atoms				ZeroOcc	AltConf
3	E	1	Total	C	O	P	0	0
			10	3	6	1		
3	F	1	Total	C	O	P	0	0
			10	3	6	1		
3	G	1	Total	C	O	P	0	0
			10	3	6	1		
3	G	1	Total	C	O	P	0	0
			10	3	6	1		
3	H	1	Total	C	O	P	0	0
			10	3	6	1		
3	H	1	Total	C	O	P	0	0
			10	3	6	1		
3	I	1	Total	C	O	P	0	0
			10	3	6	1		
3	I	1	Total	C	O	P	0	0
			10	3	6	1		
3	J	1	Total	C	O	P	0	0
			10	3	6	1		
3	K	1	Total	C	O	P	0	0
			10	3	6	1		
3	L	1	Total	C	O	P	0	0
			10	3	6	1		

- Molecule 4 is water.

Mol	Chain	Residues	Atoms		ZeroOcc	AltConf
4	A	147	Total	O	0	0
			147	147		
4	B	145	Total	O	0	0
			145	145		
4	C	93	Total	O	0	0
			93	93		
4	D	60	Total	O	0	0
			60	60		
4	E	52	Total	O	0	0
			52	52		
4	F	49	Total	O	0	0
			49	49		
4	G	125	Total	O	0	0
			125	125		
4	H	132	Total	O	0	0
			132	132		

Continued on next page...

Continued from previous page...

Mol	Chain	Residues	Atoms		ZeroOcc	AltConf
4	I	136	Total 136	O 136	0	0
4	J	136	Total 136	O 136	0	0
4	K	37	Total 37	O 37	0	0
4	L	66	Total 66	O 66	0	0

3 Residue-property plots [i](#)

These plots are drawn for all protein, RNA, DNA and oligosaccharide chains in the entry. The first graphic for a chain summarises the proportions of the various outlier classes displayed in the second graphic. The second graphic shows the sequence view annotated by issues in geometry and electron density. Residues are color-coded according to the number of geometric quality criteria for which they contain at least one outlier: green = 0, yellow = 1, orange = 2 and red = 3 or more. A red dot above a residue indicates a poor fit to the electron density ($RSRZ > 2$). Stretches of 2 or more consecutive residues without any outlier are shown as a green connector. Residues present in the sample, but not in the model, are shown in grey.

- Molecule 1: 2-dehydro-3-deoxyphosphooctonate aldolase

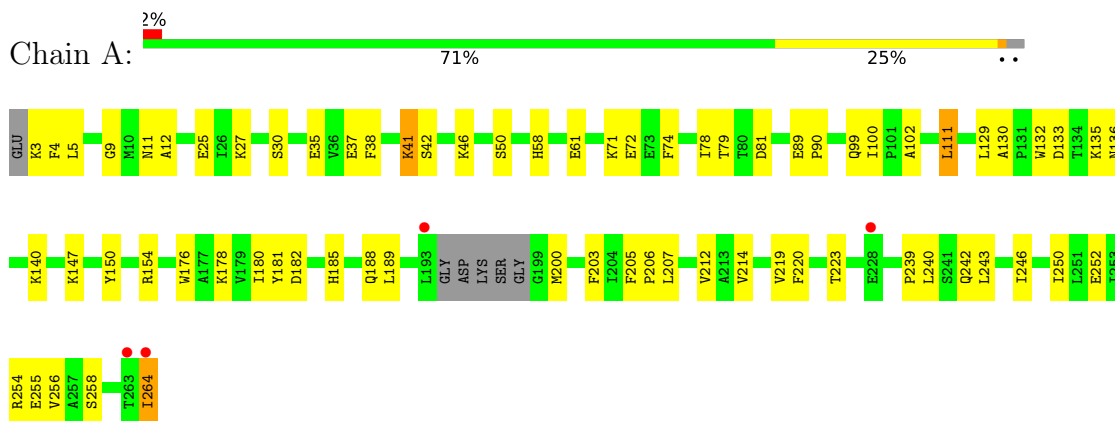

- Molecule 1: 2-dehydro-3-deoxyphosphooctonate aldolase

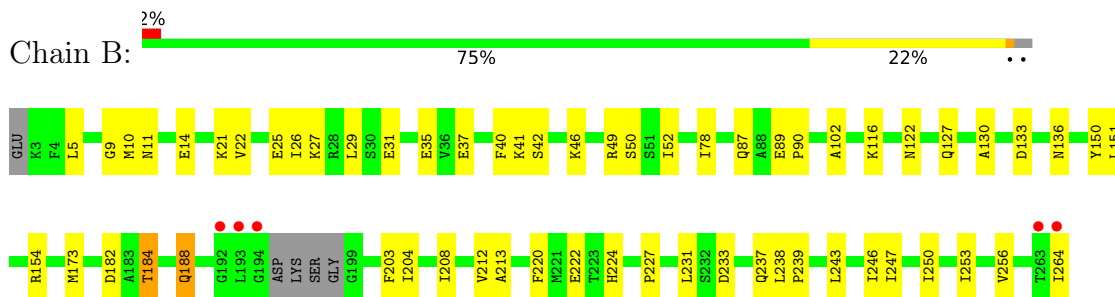

- Molecule 1: 2-dehydro-3-deoxyphosphooctonate aldolase

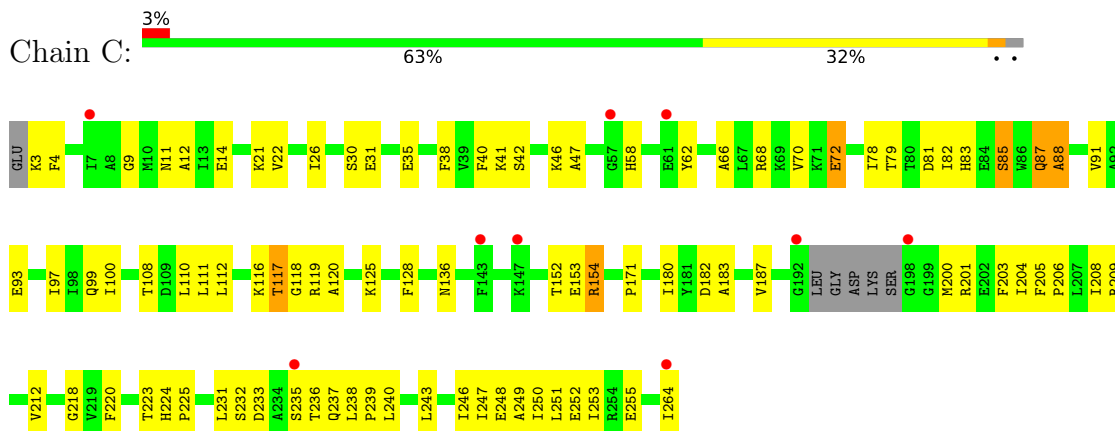

- Molecule 1: 2-dehydro-3-deoxyphosphooctonate aldolase

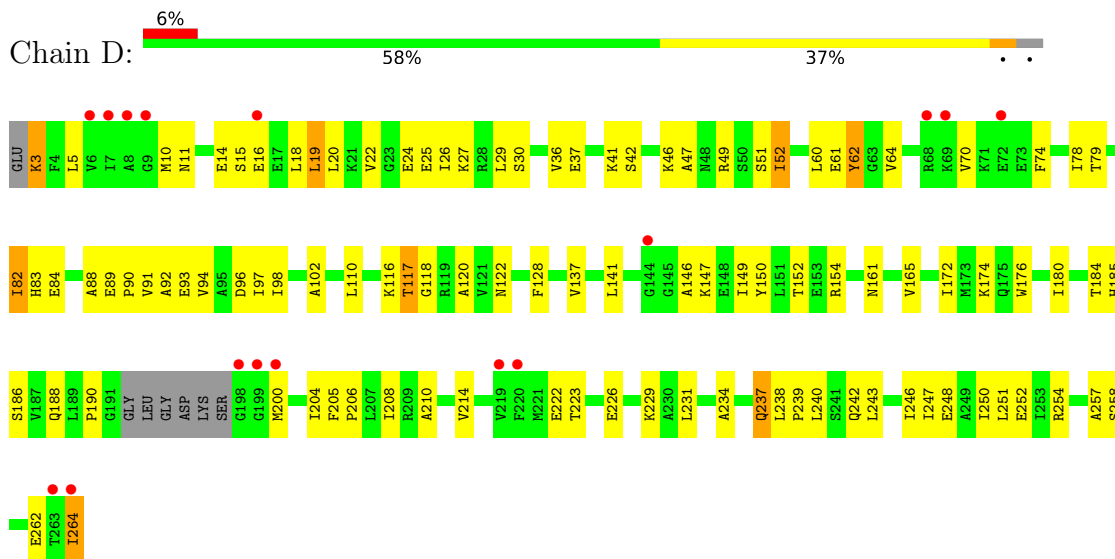

- Molecule 1: 2-dehydro-3-deoxyphosphooctonate aldolase

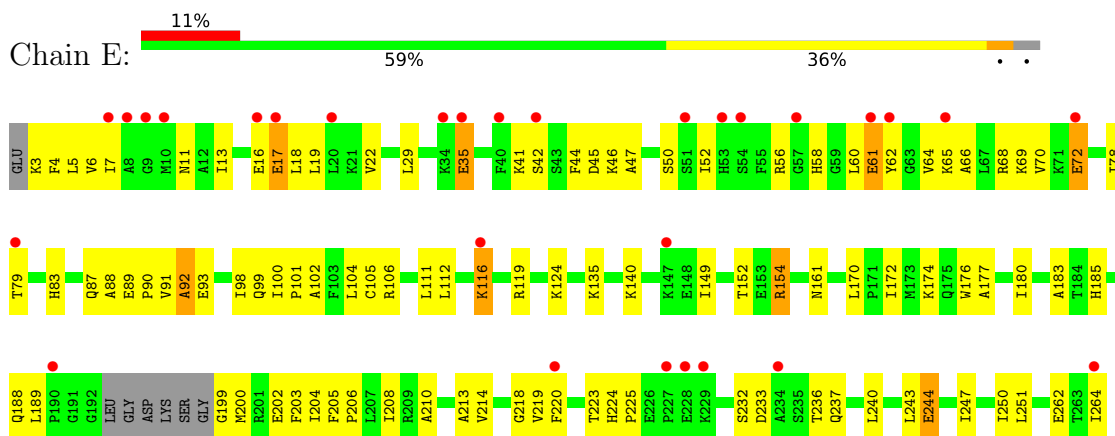

- Molecule 1: 2-dehydro-3-deoxyphosphooctonate aldolase

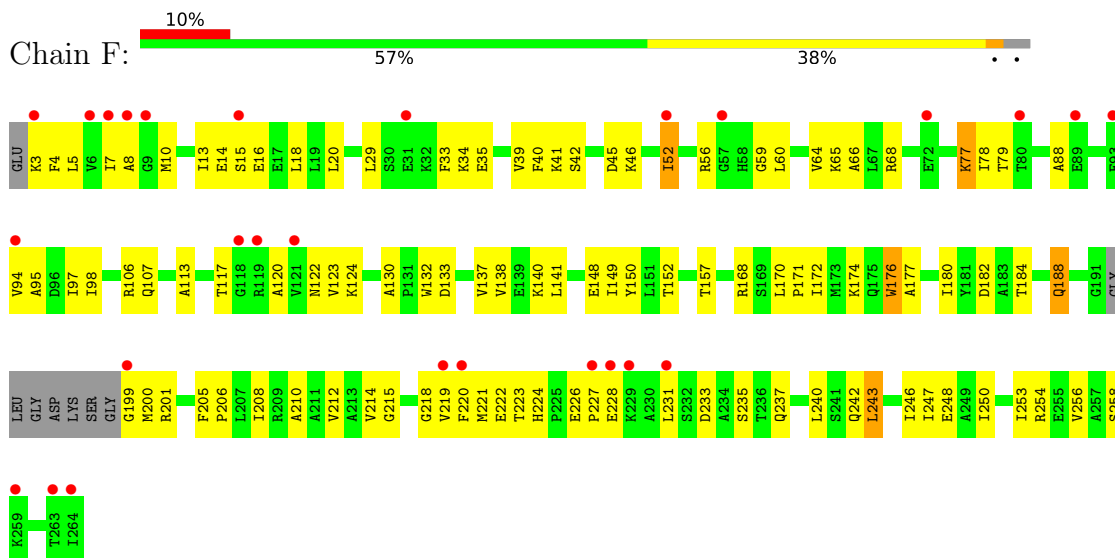

- Molecule 1: 2-dehydro-3-deoxyphosphooctonate aldolase

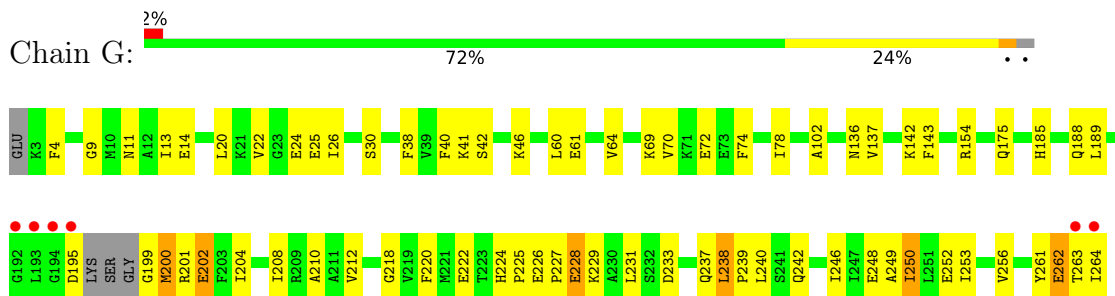

- Molecule 1: 2-dehydro-3-deoxyphosphooctonate aldolase

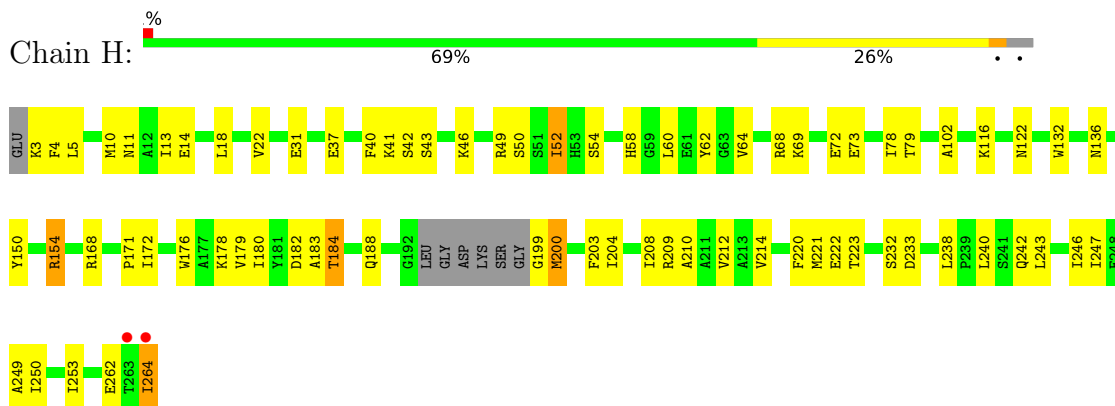

- Molecule 1: 2-dehydro-3-deoxyphosphooctonate aldolase

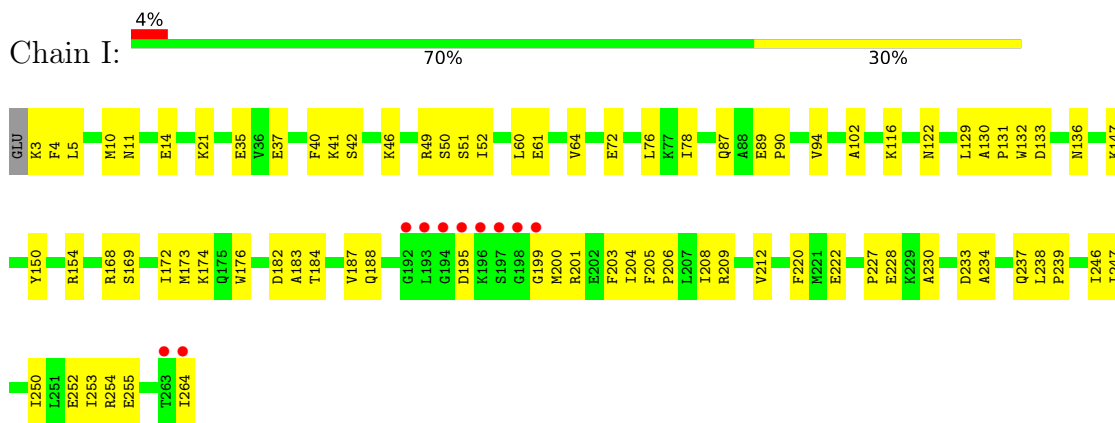

- Molecule 1: 2-dehydro-3-deoxyphosphooctonate aldolase

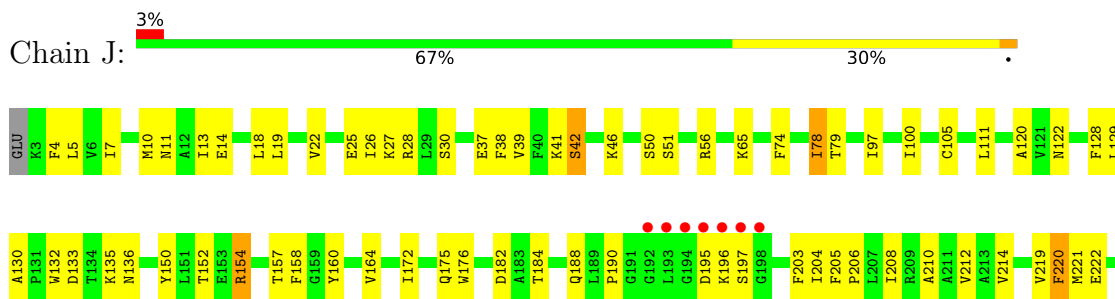



- Molecule 1: 2-dehydro-3-deoxyphosphooctonate aldolase

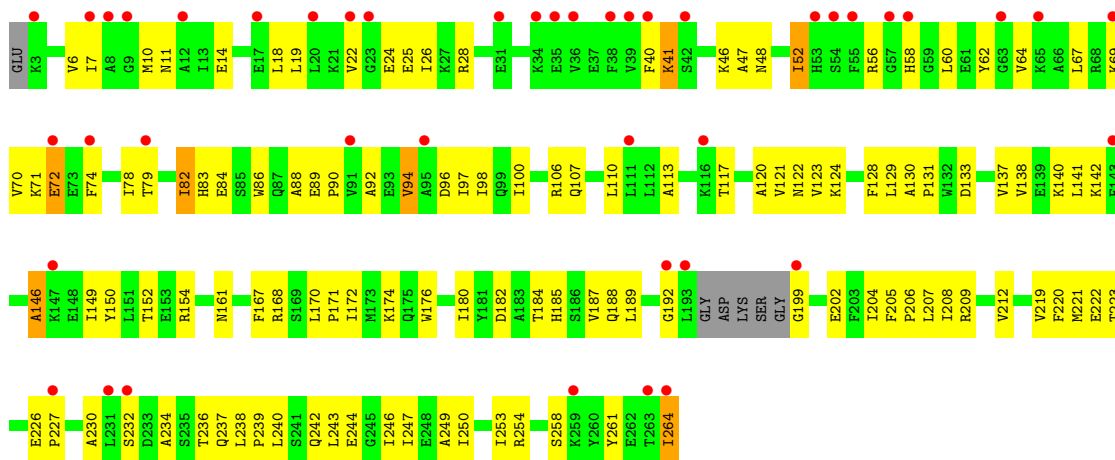

- Molecule 1: 2-dehydro-3-deoxyphosphooctonate aldolase

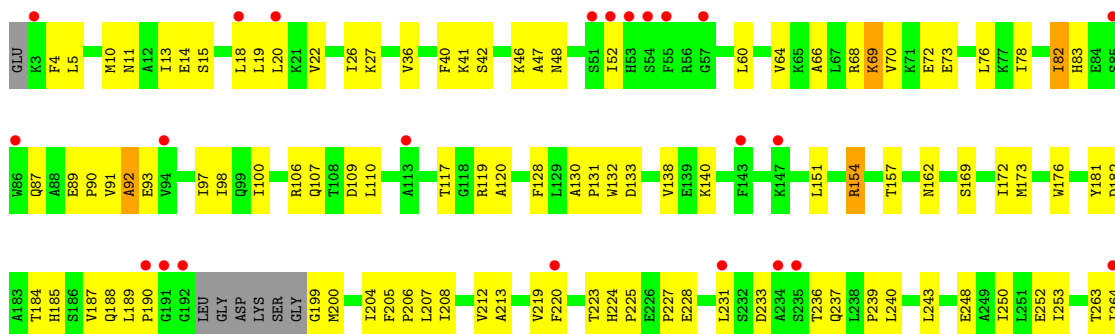

4 Data and refinement statistics

Property	Value	Source
Space group	P 1 21 1	Depositor
Cell constants a, b, c, α , β , γ	75.88Å 197.47Å 124.87Å 90.00° 93.84° 90.00°	Depositor
Resolution (Å)	25.00 – 2.30 25.24 – 2.22	Depositor EDS
% Data completeness (in resolution range)	76.3 (25.00-2.30) 69.6 (25.24-2.22)	Depositor EDS
R_{merge}	0.13	Depositor
R_{sym}	0.13	Depositor
$\langle I/\sigma(I) \rangle$ ¹	2.28 (at 2.22Å)	Xtrriage
Refinement program	CNS 1.1	Depositor
R, R_{free}	0.207 , 0.267 0.205 , 0.264	Depositor DCC
R_{free} test set	6337 reflections (5.04%)	wwPDB-VP
Wilson B-factor (Å ²)	30.0	Xtrriage
Anisotropy	0.743	Xtrriage
Bulk solvent k_{sol} (e/Å ³), B_{sol} (Å ²)	0.32 , 50.4	EDS
L-test for twinning ²	$\langle L \rangle = 0.50$, $\langle L^2 \rangle = 0.33$	Xtrriage
Estimated twinning fraction	No twinning to report.	Xtrriage
F_o, F_c correlation	0.95	EDS
Total number of atoms	25761	wwPDB-VP
Average B, all atoms (Å ²)	55.0	wwPDB-VP

Xtrriage's analysis on translational NCS is as follows: *The analyses of the Patterson function reveals a significant off-origin peak that is 21.62 % of the origin peak, indicating pseudo-translational symmetry. The chance of finding a peak of this or larger height randomly in a structure without pseudo-translational symmetry is equal to 6.7524e-03. The detected translational NCS is most likely also responsible for the elevated intensity ratio.*

¹Intensities estimated from amplitudes.

²Theoretical values of $\langle |L| \rangle$, $\langle L^2 \rangle$ for acentric reflections are 0.5, 0.333 respectively for untwinned datasets, and 0.375, 0.2 for perfectly twinned datasets.

5 Model quality

5.1 Standard geometry

Bond lengths and bond angles in the following residue types are not validated in this section: PO4, PEP

The Z score for a bond length (or angle) is the number of standard deviations the observed value is removed from the expected value. A bond length (or angle) with $|Z| > 5$ is considered an outlier worth inspection. RMSZ is the root-mean-square of all Z scores of the bond lengths (or angles).

Mol	Chain	Bond lengths		Bond angles	
		RMSZ	# Z >5	RMSZ	# Z >5
1	A	0.45	1/2068 (0.0%)	0.65	0/2786
1	B	0.41	0/2072	0.62	0/2791
1	C	0.39	1/2064 (0.0%)	0.58	0/2780
1	D	0.34	0/2060	0.59	0/2775
1	E	0.37	1/2060 (0.0%)	0.53	0/2775
1	F	0.33	0/2056	0.55	0/2770
1	G	0.43	1/2080 (0.0%)	0.62	0/2802
1	H	0.40	0/2060	0.64	0/2775
1	I	0.42	1/2100 (0.0%)	0.62	0/2829
1	J	0.40	0/2100	0.62	0/2829
1	K	0.35	1/2068 (0.0%)	0.53	0/2786
1	L	0.34	0/2060	0.56	0/2775
All	All	0.39	6/24848 (0.0%)	0.59	0/33473

All (6) bond length outliers are listed below:

Mol	Chain	Res	Type	Atoms	Z	Observed(Å)	Ideal(Å)
1	G	72	GLU	CD-OE2	7.77	1.34	1.25
1	A	72	GLU	CD-OE2	7.76	1.34	1.25
1	E	72	GLU	CD-OE2	7.32	1.33	1.25
1	K	72	GLU	CD-OE2	7.22	1.33	1.25
1	I	72	GLU	CD-OE2	7.22	1.33	1.25
1	C	72	GLU	CD-OE2	7.09	1.33	1.25

There are no bond angle outliers.

There are no chirality outliers.

There are no planarity outliers.

5.2 Too-close contacts

In the following table, the Non-H and H(model) columns list the number of non-hydrogen atoms and hydrogen atoms in the chain respectively. The H(added) column lists the number of hydrogen atoms added and optimized by MolProbity. The Clashes column lists the number of clashes within the asymmetric unit, whereas Symm-Clashes lists symmetry-related clashes.

Mol	Chain	Non-H	H(model)	H(added)	Clashes	Symm-Clashes
1	A	2029	0	2069	62	0
1	B	2033	0	2072	52	0
1	C	2025	0	2061	75	0
1	D	2021	0	2058	86	0
1	E	2021	0	2058	80	0
1	F	2017	0	2055	89	0
1	G	2041	0	2076	55	0
1	H	2021	0	2058	68	0
1	I	2060	0	2098	64	0
1	J	2060	0	2098	64	0
1	K	2029	0	2069	112	0
1	L	2021	0	2058	82	0
2	A	5	0	0	0	0
2	D	5	0	0	0	0
2	E	5	0	0	0	0
2	F	5	0	0	0	0
2	J	5	0	0	1	0
2	K	5	0	0	0	0
2	L	5	0	0	0	0
3	A	10	0	2	0	0
3	B	20	0	4	5	0
3	C	20	0	4	0	0
3	D	10	0	2	1	0
3	E	10	0	2	1	0
3	F	10	0	2	2	0
3	G	20	0	4	0	0
3	H	20	0	4	3	0
3	I	20	0	4	2	0
3	J	10	0	2	1	0
3	K	10	0	2	0	0
3	L	10	0	2	1	0
4	A	147	0	0	5	0
4	B	145	0	0	3	0
4	C	93	0	0	9	0
4	D	60	0	0	6	0
4	E	52	0	0	3	0
4	F	49	0	0	4	0

Continued on next page...

Continued from previous page...

Mol	Chain	Non-H	H(model)	H(added)	Clashes	Symm-Clashes
4	G	125	0	0	7	0
4	H	132	0	0	3	0
4	I	136	0	0	6	0
4	J	136	0	0	3	0
4	K	37	0	0	5	0
4	L	66	0	0	7	0
All	All	25761	0	24864	845	0

The all-atom clashscore is defined as the number of clashes found per 1000 atoms (including hydrogen atoms). The all-atom clashscore for this structure is 17.

All (845) close contacts within the same asymmetric unit are listed below, sorted by their clash magnitude.

Atom-1	Atom-2	Interatomic distance (Å)	Clash overlap (Å)
1:B:184:THR:HG21	1:B:222:GLU:H	1.21	1.06
1:H:184:THR:HG21	1:H:222:GLU:H	1.20	1.04
1:D:146:ALA:HB1	1:D:149:ILE:HD11	1.37	1.00
1:K:188:GLN:HA	1:K:199:GLY:HA3	1.44	0.99
1:C:238:LEU:HD12	1:C:239:PRO:HD2	1.50	0.94
1:K:161:ASN:HD21	1:L:132:TRP:HE1	1.20	0.90
1:G:185:HIS:O	1:G:188:GLN:HG2	1.73	0.89
1:K:212:VAL:HG11	1:K:250:ILE:HG23	1.57	0.87
1:I:184:THR:HG21	1:I:222:GLU:H	1.41	0.85
1:D:264:ILE:HD13	1:D:264:ILE:H	1.42	0.85
1:A:212:VAL:HG11	1:A:250:ILE:HG23	1.60	0.84
1:K:71:LYS:HB2	1:K:78:ILE:HD11	1.61	0.82
1:H:188:GLN:HA	1:H:199:GLY:HA3	1.62	0.82
1:L:13:ILE:HG23	1:L:19:LEU:HD22	1.61	0.82
1:J:46:LYS:HE2	1:J:46:LYS:HA	1.61	0.81
1:B:212:VAL:HG11	1:B:250:ILE:HG23	1.63	0.80
1:A:3:LYS:HG3	1:A:35:GLU:O	1.82	0.80
1:F:15:SER:HB2	1:F:18:LEU:HB2	1.64	0.79
1:E:250:ILE:HD12	1:E:251:LEU:N	1.98	0.79
1:K:82:ILE:HG12	1:K:110:LEU:HD11	1.63	0.79
1:L:263:THR:HG22	1:L:264:ILE:HG23	1.64	0.79
1:C:11:ASN:H	1:C:237:GLN:HE22	1.31	0.78
1:B:188:GLN:HB2	4:B:280:HOH:O	1.83	0.78
1:D:11:ASN:HB2	1:D:237:GLN:HE22	1.48	0.78
1:D:146:ALA:CB	1:D:149:ILE:HD11	2.14	0.78
1:K:7:ILE:HD12	1:K:7:ILE:H	1.49	0.77
1:G:202:GLU:HG3	4:G:370:HOH:O	1.85	0.76

Continued on next page...

Continued from previous page...

Atom-1	Atom-2	Interatomic distance (Å)	Clash overlap (Å)
1:D:141:LEU:HD13	1:D:149:ILE:HD12	1.68	0.76
1:E:161:ASN:HD21	1:F:132:TRP:HE1	1.29	0.75
1:B:10:MET:HE1	1:B:14:GLU:HG3	1.68	0.75
1:I:174:LYS:HG3	1:I:264:ILE:HG12	1.68	0.75
1:H:182:ASP:HA	1:H:220:PHE:HB3	1.69	0.74
1:I:203:PHE:HZ	1:L:172:ILE:HD11	1.51	0.74
1:K:189:LEU:HG	1:K:199:GLY:HA2	1.68	0.74
1:C:12:ALA:HB2	1:C:46:LYS:HD3	1.70	0.74
1:D:223:THR:HG21	1:D:243:LEU:HD11	1.69	0.74
1:C:238:LEU:HD21	1:C:246:ILE:HD12	1.70	0.73
1:B:184:THR:CG2	1:B:222:GLU:H	1.99	0.73
1:D:204:ILE:O	1:D:208:ILE:HG13	1.88	0.73
1:K:188:GLN:HB3	1:K:236:THR:HG21	1.71	0.72
1:F:256:VAL:HG21	1:G:256:VAL:HG11	1.70	0.72
1:K:246:ILE:O	1:K:250:ILE:HG12	1.89	0.72
1:I:204:ILE:HG21	1:I:238:LEU:HD11	1.72	0.71
1:A:150:TYR:CD1	1:A:180:ILE:HD11	2.25	0.71
1:J:7:ILE:HD13	1:J:39:VAL:HB	1.72	0.71
1:I:37:GLU:HG3	4:I:334:HOH:O	1.90	0.71
1:C:97:ILE:HD13	1:C:120:ALA:HB3	1.71	0.71
1:C:182:ASP:HA	1:C:220:PHE:HB3	1.72	0.71
1:L:248:GLU:O	1:L:252:GLU:HG3	1.91	0.71
1:C:187:VAL:HG21	1:C:204:ILE:HG12	1.73	0.71
1:F:188:GLN:HA	1:F:199:GLY:HA3	1.71	0.71
1:C:88:ALA:HB3	4:C:324:HOH:O	1.91	0.70
1:K:10:MET:HE2	1:K:14:GLU:HG3	1.73	0.70
1:E:64:VAL:HG12	1:E:68:ARG:HH12	1.56	0.69
1:C:35:GLU:CD	1:C:35:GLU:H	1.96	0.69
1:A:41:LYS:HD2	1:A:42:SER:N	2.08	0.69
1:A:178:LYS:HD2	4:A:369:HOH:O	1.92	0.69
1:F:59:GLY:HA3	4:F:277:HOH:O	1.92	0.69
1:K:204:ILE:O	1:K:208:ILE:HG13	1.92	0.69
1:C:248:GLU:O	1:C:252:GLU:HG3	1.92	0.68
1:G:189:LEU:HG	1:G:199:GLY:HA2	1.74	0.68
1:G:264:ILE:HD12	1:G:264:ILE:OXT	1.92	0.68
1:I:209:ARG:HG2	1:I:253:ILE:CD1	2.22	0.68
1:I:228:GLU:HG2	4:I:320:HOH:O	1.93	0.68
1:J:204:ILE:O	1:J:208:ILE:HG13	1.94	0.68
1:K:11:ASN:HD21	1:K:46:LYS:HE2	1.56	0.68
1:A:189:LEU:HD21	1:A:200:MET:CE	2.24	0.68
1:B:256:VAL:HG13	1:C:253:ILE:HD13	1.76	0.68

Continued on next page...

Continued from previous page...

Atom-1	Atom-2	Interatomic distance (Å)	Clash overlap (Å)
1:E:60:LEU:HD23	1:E:60:LEU:O	1.93	0.68
1:L:15:SER:OG	1:L:18:LEU:HD13	1.93	0.68
1:I:182:ASP:HA	1:I:220:PHE:HB3	1.76	0.68
1:I:255:GLU:HG2	4:I:302:HOH:O	1.93	0.68
1:D:243:LEU:O	1:D:247:ILE:HG13	1.95	0.67
1:I:89:GLU:HB3	1:I:90:PRO:HD3	1.76	0.67
1:J:97:ILE:HD13	1:J:120:ALA:HB3	1.76	0.67
1:A:189:LEU:HD21	1:A:200:MET:HE2	1.76	0.67
1:C:41:LYS:HE3	1:C:220:PHE:HZ	1.60	0.67
1:C:201:ARG:HG3	1:C:235:SER:O	1.95	0.67
1:E:188:GLN:HB2	1:E:236:THR:HG21	1.76	0.67
1:A:203:PHE:HZ	1:D:172:ILE:HD11	1.59	0.67
1:F:7:ILE:HD12	1:F:39:VAL:HB	1.76	0.67
1:L:41:LYS:HD3	1:L:42:SER:N	2.09	0.66
1:F:52:ILE:HD13	1:F:52:ILE:O	1.94	0.66
1:H:3:LYS:N	4:H:321:HOH:O	2.28	0.66
1:F:170:LEU:HB2	1:F:171:PRO:HD3	1.76	0.66
1:F:205:PHE:HB3	1:F:206:PRO:HD3	1.78	0.66
1:D:205:PHE:HB3	1:D:206:PRO:HD3	1.77	0.66
1:A:264:ILE:HD13	1:A:264:ILE:H	1.60	0.66
1:D:60:LEU:HD23	1:D:60:LEU:O	1.96	0.66
1:J:212:VAL:HG21	1:J:250:ILE:HB	1.76	0.66
1:H:31:GLU:HG3	4:H:326:HOH:O	1.95	0.66
1:I:233:ASP:O	1:I:237:GLN:HG2	1.95	0.66
1:D:52:ILE:HD13	1:D:52:ILE:O	1.96	0.66
1:K:185:HIS:O	1:K:188:GLN:HG2	1.96	0.66
1:K:130:ALA:HB3	1:K:133:ASP:OD2	1.96	0.65
1:C:243:LEU:O	1:C:247:ILE:HG12	1.95	0.65
1:B:154:ARG:HH22	1:B:188:GLN:HE22	1.45	0.65
1:D:96:ASP:HB2	1:D:97:ILE:HD12	1.79	0.65
1:J:184:THR:HG21	1:J:222:GLU:H	1.62	0.65
1:K:182:ASP:HA	1:K:220:PHE:HB3	1.78	0.65
1:L:82:ILE:HD13	1:L:82:ILE:H	1.62	0.65
1:L:106:ARG:HA	4:L:275:HOH:O	1.97	0.65
1:E:204:ILE:O	1:E:208:ILE:HG13	1.97	0.65
1:F:13:ILE:HB	4:F:285:HOH:O	1.96	0.64
1:G:69:LYS:HG2	4:G:369:HOH:O	1.97	0.64
1:C:212:VAL:HG11	1:C:250:ILE:HB	1.80	0.64
1:A:41:LYS:HB2	1:A:79:THR:HG23	1.80	0.64
1:L:188:GLN:HA	1:L:199:GLY:HA3	1.80	0.64
1:C:224:HIS:HB2	1:C:237:GLN:HG2	1.80	0.64

Continued on next page...

Continued from previous page...

Atom-1	Atom-2	Interatomic distance (Å)	Clash overlap (Å)
1:G:11:ASN:H	1:G:237:GLN:NE2	1.95	0.64
1:I:204:ILE:O	1:I:208:ILE:HG13	1.98	0.64
1:I:204:ILE:HD13	1:I:238:LEU:HD11	1.79	0.64
1:J:10:MET:HG3	1:J:22:VAL:HG21	1.79	0.64
1:G:212:VAL:HG11	1:G:250:ILE:HB	1.79	0.63
1:J:248:GLU:O	1:J:252:GLU:HG3	1.99	0.63
1:B:233:ASP:O	1:B:237:GLN:HG3	1.98	0.63
1:F:184:THR:HG21	1:F:222:GLU:H	1.62	0.63
1:G:136:ASN:HB3	1:H:50:SER:O	1.98	0.63
1:I:11:ASN:HD21	1:I:46:LYS:HE2	1.62	0.63
1:K:71:LYS:HB2	1:K:78:ILE:CD1	2.28	0.63
1:K:129:LEU:HA	4:K:1155:HOH:O	1.99	0.63
1:I:51:SER:HB2	1:I:195:ASP:HB2	1.81	0.63
1:C:82:ILE:HG13	1:C:110:LEU:HD11	1.81	0.63
1:D:64:VAL:HG13	1:D:94:VAL:HG11	1.80	0.63
1:F:40:PHE:HB3	1:F:78:ILE:HD13	1.80	0.62
1:D:64:VAL:HG13	1:D:94:VAL:CG1	2.29	0.62
1:D:246:ILE:O	1:D:250:ILE:HG12	2.00	0.62
1:H:10:MET:HE1	1:H:14:GLU:HG3	1.82	0.62
1:C:100:ILE:HG13	1:C:111:LEU:HD23	1.82	0.62
1:L:130:ALA:HB3	1:L:133:ASP:OD2	2.00	0.62
1:A:100:ILE:CD1	1:A:111:LEU:HD12	2.30	0.61
1:L:40:PHE:HB3	1:L:78:ILE:HD13	1.82	0.61
1:L:89:GLU:HB3	1:L:90:PRO:HD3	1.82	0.61
1:L:66:ALA:O	1:L:70:VAL:HG23	2.01	0.61
1:K:184:THR:HG21	1:K:222:GLU:H	1.66	0.61
1:L:154:ARG:NH2	1:L:185:HIS:HB3	2.15	0.61
1:E:200:MET:HB2	1:E:203:PHE:HD2	1.66	0.60
1:G:228:GLU:H	1:G:228:GLU:CD	2.02	0.60
1:E:223:THR:HG21	1:E:243:LEU:HD21	1.83	0.60
1:H:221:MET:HE1	1:H:246:ILE:HG21	1.82	0.60
1:H:223:THR:OG1	1:H:243:LEU:HD21	2.00	0.60
1:G:69:LYS:HE2	4:G:369:HOH:O	2.00	0.60
1:K:64:VAL:HG13	1:K:94:VAL:HG11	1.82	0.60
1:A:3:LYS:N	4:A:372:HOH:O	2.34	0.60
1:G:246:ILE:O	1:G:250:ILE:HG23	2.02	0.60
1:H:11:ASN:HD22	1:H:232:SER:HB3	1.67	0.60
1:D:89:GLU:N	1:D:90:PRO:HD2	2.17	0.60
1:L:97:ILE:HD13	1:L:120:ALA:HB3	1.83	0.60
1:D:185:HIS:O	1:D:188:GLN:HG2	2.02	0.59
1:F:243:LEU:HD22	1:F:247:ILE:HD11	1.83	0.59

Continued on next page...

Continued from previous page...

Atom-1	Atom-2	Interatomic distance (Å)	Clash overlap (Å)
1:A:41:LYS:HB2	1:A:79:THR:CG2	2.33	0.59
1:D:46:LYS:HA	1:D:46:LYS:HE2	1.83	0.59
1:D:82:ILE:HD12	1:D:98:ILE:CG2	2.32	0.59
1:F:46:LYS:HZ1	3:F:268:PEP:H31	1.66	0.59
1:K:92:ALA:HB1	1:K:117:THR:OG1	2.02	0.59
1:C:208:ILE:CG2	1:C:250:ILE:HG21	2.32	0.59
1:K:67:LEU:HG	1:K:78:ILE:HD13	1.82	0.59
1:F:14:GLU:HG2	1:F:231:LEU:HD12	1.84	0.59
1:G:201:ARG:HG3	4:G:370:HOH:O	2.01	0.59
1:K:223:THR:OG1	1:K:240:LEU:HA	2.03	0.59
1:F:208:ILE:HG21	1:F:250:ILE:HD11	1.85	0.59
1:K:174:LYS:HG2	1:K:264:ILE:HD11	1.85	0.59
1:B:27:LYS:O	1:B:31:GLU:HG2	2.03	0.59
1:C:136:ASN:HD22	1:D:51:SER:HA	1.67	0.59
1:G:249:ALA:O	1:G:253:ILE:HG12	2.03	0.59
1:I:209:ARG:HD2	1:L:213:ALA:O	2.03	0.59
1:I:5:LEU:HD12	1:I:37:GLU:O	2.02	0.58
1:B:49:ARG:HD2	3:B:269:PEP:O1P	2.03	0.58
1:I:49:ARG:HD2	3:I:269:PEP:H32	1.83	0.58
1:K:96:ASP:HB2	1:K:97:ILE:HD12	1.85	0.58
1:C:22:VAL:O	1:C:26:ILE:HG12	2.03	0.58
1:F:124:LYS:HD3	1:F:152:THR:HB	1.84	0.58
1:C:125:LYS:NZ	1:C:153:GLU:OE1	2.33	0.58
1:E:64:VAL:HG12	1:E:68:ARG:NH1	2.17	0.58
1:H:10:MET:HG3	1:H:22:VAL:HG21	1.85	0.58
1:K:25:GLU:OE1	1:K:28:ARG:HD3	2.04	0.58
1:K:168:ARG:O	1:K:172:ILE:HG12	2.03	0.58
1:B:11:ASN:HD21	1:B:46:LYS:HE2	1.69	0.58
1:J:249:ALA:O	1:J:253:ILE:HG12	2.04	0.58
1:E:5:LEU:HD23	1:E:6:VAL:N	2.18	0.58
1:E:100:ILE:HG12	1:E:111:LEU:HD23	1.86	0.58
1:G:242:GLN:O	1:G:246:ILE:HG12	2.03	0.58
1:L:41:LYS:HD3	1:L:41:LYS:C	2.23	0.58
1:G:226:GLU:OE1	1:G:229:LYS:HD2	2.03	0.58
1:K:205:PHE:HB3	1:K:206:PRO:HD3	1.86	0.58
1:K:138:VAL:O	1:K:142:LYS:HG2	2.04	0.58
1:K:264:ILE:HD13	1:K:264:ILE:H	1.69	0.57
1:E:4:PHE:HZ	1:E:219:VAL:HG23	1.68	0.57
1:I:87:GLN:O	1:I:90:PRO:HD2	2.04	0.57
1:J:27:LYS:HD3	1:J:74:PHE:O	2.04	0.57
1:L:208:ILE:CG2	1:L:250:ILE:HG21	2.34	0.57

Continued on next page...

Continued from previous page...

Atom-1	Atom-2	Interatomic distance (Å)	Clash overlap (Å)
1:H:200:MET:HB2	1:H:203:PHE:CD2	2.40	0.57
1:B:182:ASP:HA	1:B:220:PHE:HB3	1.86	0.57
1:K:41:LYS:HZ2	1:K:220:PHE:HZ	1.51	0.57
1:E:47:ALA:O	1:F:107:GLN:HA	2.05	0.57
1:J:132:TRP:HA	1:J:176:TRP:CH2	2.40	0.57
1:K:83:HIS:HD2	4:K:613:HOH:O	1.86	0.57
1:K:123:VAL:HG11	1:K:137:VAL:HG11	1.86	0.57
1:D:154:ARG:HH22	1:D:188:GLN:NE2	2.03	0.57
1:D:15:SER:O	1:D:19:LEU:HB2	2.05	0.57
1:E:66:ALA:O	1:E:70:VAL:HG23	2.04	0.57
1:F:123:VAL:HG11	1:F:137:VAL:HG11	1.86	0.57
1:K:187:VAL:HG12	1:K:207:LEU:HD12	1.87	0.57
1:A:185:HIS:O	1:A:188:GLN:HB3	2.05	0.56
1:A:256:VAL:HG21	1:D:252:GLU:HB3	1.87	0.56
1:H:116:LYS:O	1:H:116:LYS:HG2	2.05	0.56
1:B:212:VAL:HG23	1:B:253:ILE:HG21	1.87	0.56
1:B:264:ILE:HG13	4:B:346:HOH:O	2.04	0.56
1:B:49:ARG:NH2	1:B:231:LEU:O	2.38	0.56
1:C:154:ARG:HG3	4:C:272:HOH:O	2.04	0.56
1:D:14:GLU:HG2	1:D:231:LEU:HD12	1.86	0.56
1:F:60:LEU:O	1:F:64:VAL:HG23	2.06	0.56
1:K:243:LEU:O	1:K:247:ILE:HG13	2.04	0.56
1:C:208:ILE:HG22	1:C:250:ILE:HG21	1.86	0.56
1:E:13:ILE:HG12	1:E:19:LEU:HD21	1.87	0.56
1:C:264:ILE:HD12	1:C:264:ILE:OXT	2.05	0.56
1:E:149:ILE:HD12	1:E:149:ILE:N	2.20	0.56
1:F:45:ASP:HA	1:F:56:ARG:O	2.05	0.56
1:I:183:ALA:HB2	1:I:208:ILE:HG12	1.87	0.56
1:A:147:LYS:HE3	4:A:317:HOH:O	2.05	0.56
1:F:246:ILE:O	1:F:250:ILE:HD13	2.06	0.56
1:K:249:ALA:O	1:K:253:ILE:HG12	2.06	0.56
1:L:68:ARG:O	1:L:72:GLU:HG3	2.06	0.56
1:D:15:SER:OG	1:D:18:LEU:HD13	2.06	0.56
1:H:49:ARG:CZ	1:H:54:SER:HB3	2.36	0.56
1:K:264:ILE:HD13	1:K:264:ILE:N	2.21	0.56
1:D:16:GLU:HB2	1:D:62:TYR:HE2	1.71	0.56
1:E:206:PRO:HG3	1:H:262:GLU:OE1	2.05	0.56
1:H:168:ARG:O	1:H:171:PRO:HD2	2.05	0.55
1:K:209:ARG:O	1:K:212:VAL:HG22	2.06	0.55
1:B:151:LEU:HB3	1:B:173:MET:CE	2.37	0.55
1:E:89:GLU:HB2	1:E:90:PRO:HD3	1.89	0.55

Continued on next page...

Continued from previous page...

Atom-1	Atom-2	Interatomic distance (Å)	Clash overlap (Å)
1:I:50:SER:O	1:J:136:ASN:HB3	2.06	0.55
1:J:188:GLN:O	1:J:190:PRO:HD3	2.07	0.55
1:L:223:THR:HG21	1:L:243:LEU:HD22	1.88	0.55
1:I:188:GLN:HA	1:I:199:GLY:HA3	1.89	0.55
1:C:200:MET:HG2	4:C:318:HOH:O	2.05	0.55
1:K:11:ASN:ND2	1:K:232:SER:OG	2.40	0.55
1:K:71:LYS:HD2	1:K:78:ILE:HD12	1.87	0.55
1:K:227:PRO:O	1:K:234:ALA:HB1	2.07	0.55
1:L:169:SER:O	1:L:173:MET:HG3	2.07	0.55
1:D:20:LEU:HD23	1:D:70:VAL:HG22	1.88	0.55
1:K:154:ARG:NH2	1:K:185:HIS:HB3	2.22	0.55
1:J:233:ASP:O	1:J:237:GLN:HG3	2.05	0.55
1:L:69:LYS:HD2	1:L:73:GLU:OE1	2.07	0.55
1:C:58:HIS:HB2	1:C:62:TYR:CD2	2.42	0.54
1:D:97:ILE:HD12	1:D:97:ILE:N	2.22	0.54
1:E:4:PHE:CZ	1:E:219:VAL:HG23	2.41	0.54
1:E:91:VAL:C	1:E:93:GLU:H	2.10	0.54
1:J:203:PHE:HZ	1:K:172:ILE:HD11	1.72	0.54
1:K:227:PRO:HG3	1:K:239:PRO:HG3	1.89	0.54
1:A:9:GLY:HA3	1:A:41:LYS:O	2.07	0.54
1:I:87:GLN:C	1:I:90:PRO:HD2	2.28	0.54
1:K:56:ARG:HH22	1:L:109:ASP:CG	2.11	0.54
1:L:204:ILE:O	1:L:208:ILE:HG13	2.06	0.54
1:B:212:VAL:HG23	1:B:253:ILE:CG2	2.37	0.54
1:F:46:LYS:NZ	3:F:268:PEP:H31	2.22	0.54
1:J:242:GLN:O	1:J:246:ILE:HD13	2.07	0.54
1:F:205:PHE:O	1:F:208:ILE:HB	2.06	0.54
1:G:20:LEU:HD23	1:G:70:VAL:HG22	1.88	0.54
1:K:254:ARG:O	1:K:258:SER:HB3	2.07	0.54
1:E:210:ALA:O	1:E:214:VAL:HG23	2.08	0.54
1:F:210:ALA:O	1:F:214:VAL:HG23	2.07	0.54
1:B:122:ASN:HA	1:B:150:TYR:HB2	1.88	0.54
1:J:5:LEU:HD12	1:J:37:GLU:O	2.08	0.54
1:D:24:GLU:O	1:D:27:LYS:HB3	2.08	0.54
1:H:60:LEU:O	1:H:64:VAL:HG23	2.07	0.54
1:K:140:LYS:HG2	1:L:52:ILE:HB	1.90	0.54
1:A:11:ASN:HD21	1:A:46:LYS:HE2	1.73	0.54
1:G:204:ILE:O	1:G:208:ILE:HG13	2.08	0.54
1:I:201:ARG:HG3	1:I:204:ILE:HD12	1.90	0.54
1:A:252:GLU:O	1:A:255:GLU:HB3	2.08	0.53
1:E:170:LEU:O	1:E:174:LYS:HB2	2.08	0.53

Continued on next page...

Continued from previous page...

Atom-1	Atom-2	Interatomic distance (Å)	Clash overlap (Å)
1:F:150:TYR:CD1	1:F:180:ILE:HD11	2.43	0.53
1:F:41:LYS:HD3	1:F:42:SER:N	2.23	0.53
1:F:180:ILE:N	1:F:180:ILE:HD12	2.23	0.53
1:H:200:MET:HB2	1:H:203:PHE:HD2	1.73	0.53
1:I:203:PHE:CZ	1:L:172:ILE:HD11	2.38	0.53
1:D:62:TYR:HD2	1:D:62:TYR:O	1.90	0.53
1:D:184:THR:HG21	1:D:222:GLU:H	1.74	0.53
1:K:97:ILE:HG13	1:K:120:ALA:HB3	1.90	0.53
1:L:82:ILE:HG12	1:L:110:LEU:HD11	1.90	0.53
1:C:3:LYS:N	4:C:304:HOH:O	2.41	0.53
1:F:168:ARG:O	1:F:172:ILE:HG13	2.07	0.53
1:G:22:VAL:O	1:G:26:ILE:HG12	2.08	0.53
1:K:152:THR:HA	1:K:180:ILE:O	2.09	0.53
1:C:255:GLU:HG2	4:C:289:HOH:O	2.07	0.53
1:D:97:ILE:HG13	1:D:120:ALA:HB3	1.91	0.53
1:K:84:GLU:HB3	1:K:86:TRP:CD1	2.44	0.53
1:A:264:ILE:HD13	1:A:264:ILE:N	2.23	0.53
1:I:230:ALA:HB3	1:I:234:ALA:HA	1.89	0.53
1:G:30:SER:HA	1:G:38:PHE:CE2	2.44	0.53
1:H:52:ILE:HD13	1:H:52:ILE:O	2.09	0.53
1:A:61:GLU:OE1	1:G:142:LYS:NZ	2.43	0.52
1:C:233:ASP:HB3	1:C:236:THR:OG1	2.10	0.52
1:F:243:LEU:O	1:F:247:ILE:HG13	2.09	0.52
1:L:106:ARG:HH11	1:L:106:ARG:HG3	1.74	0.52
1:B:243:LEU:O	1:B:247:ILE:HG12	2.10	0.52
1:E:223:THR:OG1	1:E:243:LEU:HD11	2.08	0.52
1:H:212:VAL:HG11	1:H:250:ILE:HB	1.90	0.52
1:G:200:MET:HB3	1:G:202:GLU:OE2	2.09	0.52
1:E:29:LEU:HD21	1:E:244:GLU:HG2	1.91	0.52
1:E:180:ILE:HA	1:E:218:GLY:O	2.07	0.52
1:E:183:ALA:O	1:E:204:ILE:HG23	2.10	0.52
1:E:101:PRO:HD2	1:E:104:LEU:HD12	1.90	0.52
1:C:223:THR:OG1	1:C:240:LEU:HA	2.09	0.52
1:I:227:PRO:HG2	1:I:239:PRO:HG3	1.92	0.52
1:F:106:ARG:HG3	1:F:106:ARG:HH11	1.74	0.52
1:L:10:MET:O	1:L:42:SER:HA	2.09	0.52
1:L:162:ASN:HA	1:L:189:LEU:HD22	1.91	0.52
1:A:188:GLN:HB2	4:A:354:HOH:O	2.09	0.52
1:B:154:ARG:HH22	1:B:188:GLN:NE2	2.08	0.52
1:C:11:ASN:H	1:C:237:GLN:NE2	2.04	0.52
1:H:184:THR:CG2	1:H:222:GLU:H	2.07	0.52

Continued on next page...

Continued from previous page...

Atom-1	Atom-2	Interatomic distance (Å)	Clash overlap (Å)
1:J:132:TRP:HA	1:J:176:TRP:HH2	1.73	0.52
1:A:12:ALA:HB2	1:A:46:LYS:HD3	1.92	0.52
1:B:40:PHE:HB3	1:B:78:ILE:HD13	1.92	0.52
1:C:249:ALA:O	1:C:253:ILE:HG12	2.10	0.52
1:E:35:GLU:H	1:E:35:GLU:CD	2.14	0.52
1:E:176:TRP:O	1:E:177:ALA:HB2	2.10	0.52
1:J:22:VAL:O	1:J:26:ILE:HG12	2.09	0.52
1:H:132:TRP:HA	1:H:176:TRP:HH2	1.74	0.51
1:A:100:ILE:HD13	1:A:111:LEU:HD12	1.92	0.51
1:B:264:ILE:HG22	1:B:264:ILE:OXT	2.11	0.51
1:F:226:GLU:HB3	1:F:228:GLU:OE2	2.11	0.51
1:E:18:LEU:O	1:E:22:VAL:HG23	2.10	0.51
1:J:51:SER:HB2	1:J:195:ASP:HB2	1.91	0.51
1:C:85:SER:N	1:D:84:GLU:OE2	2.44	0.51
1:D:25:GLU:HG2	1:D:240:LEU:HG	1.92	0.51
1:G:4:PHE:CZ	1:G:218:GLY:HA2	2.46	0.51
1:H:40:PHE:HB3	1:H:78:ILE:HD13	1.92	0.51
1:K:264:ILE:H	1:K:264:ILE:CD1	2.23	0.51
1:C:47:ALA:HB1	4:D:299:HOH:O	2.10	0.51
1:E:3:LYS:HG3	1:E:35:GLU:O	2.09	0.51
1:E:41:LYS:HD3	1:E:41:LYS:C	2.31	0.51
1:K:7:ILE:HD12	1:K:7:ILE:N	2.24	0.51
1:C:9:GLY:HA3	1:C:41:LYS:O	2.11	0.51
1:F:182:ASP:HA	1:F:220:PHE:HB3	1.93	0.51
4:K:463:HOH:O	1:L:47:ALA:HB1	2.11	0.51
1:C:30:SER:HA	1:C:38:PHE:CE2	2.45	0.51
1:D:82:ILE:HD13	1:D:82:ILE:H	1.74	0.51
1:D:82:ILE:HG12	1:D:110:LEU:HD11	1.93	0.51
1:G:14:GLU:HG2	1:G:231:LEU:HD12	1.93	0.51
1:G:137:VAL:HG22	4:G:289:HOH:O	2.11	0.51
1:H:210:ALA:O	1:H:214:VAL:HG23	2.10	0.51
1:J:11:ASN:HD22	1:J:232:SER:HB3	1.76	0.51
1:L:138:VAL:HG21	1:L:176:TRP:HD1	1.75	0.51
1:F:122:ASN:HA	1:F:150:TYR:HB2	1.93	0.51
1:E:116:LYS:HB2	1:E:116:LYS:NZ	2.26	0.50
1:F:130:ALA:HB3	1:F:133:ASP:OD2	2.11	0.50
1:H:264:ILE:HG23	1:H:264:ILE:OXT	2.11	0.50
4:C:270:HOH:O	1:D:128:PHE:HB3	2.10	0.50
1:E:45:ASP:HA	1:E:56:ARG:O	2.11	0.50
1:G:61:GLU:HB2	4:G:375:HOH:O	2.11	0.50
1:K:58:HIS:HB2	1:K:62:TYR:CD2	2.46	0.50

Continued on next page...

Continued from previous page...

Atom-1	Atom-2	Interatomic distance (Å)	Clash overlap (Å)
1:A:102:ALA:HB2	1:A:154:ARG:HD3	1.92	0.50
1:B:224:HIS:O	1:B:227:PRO:HD3	2.10	0.50
1:D:91:VAL:C	1:D:93:GLU:H	2.15	0.50
1:H:180:ILE:N	1:H:180:ILE:HD12	2.26	0.50
1:C:116:LYS:C	1:C:118:GLY:H	2.15	0.50
1:E:100:ILE:HD12	1:E:100:ILE:N	2.26	0.50
1:H:102:ALA:HB2	1:H:154:ARG:HD3	1.93	0.50
1:H:122:ASN:HA	1:H:150:TYR:HB2	1.93	0.50
1:I:209:ARG:HG2	1:I:253:ILE:HD12	1.92	0.50
1:B:151:LEU:HB3	1:B:173:MET:HE2	1.93	0.50
1:D:152:THR:HA	1:D:180:ILE:O	2.12	0.50
1:D:226:GLU:OE1	1:D:229:LYS:HD2	2.11	0.50
1:F:254:ARG:O	1:F:258:SER:HB3	2.11	0.50
1:H:212:VAL:HG23	1:H:253:ILE:CG2	2.41	0.50
1:I:205:PHE:HB3	1:I:206:PRO:HD3	1.93	0.50
1:K:107:GLN:HA	1:K:107:GLN:NE2	2.26	0.50
1:L:26:ILE:HD12	1:L:40:PHE:CD1	2.47	0.50
1:C:204:ILE:O	1:C:208:ILE:HG13	2.11	0.50
1:H:154:ARG:HH22	1:H:188:GLN:HE21	1.59	0.50
1:L:14:GLU:OE2	1:L:231:LEU:HG	2.11	0.50
1:E:61:GLU:CD	1:E:61:GLU:H	2.15	0.50
1:F:5:LEU:HD21	1:F:150:TYR:OH	2.12	0.50
1:H:11:ASN:ND2	1:H:232:SER:HB3	2.25	0.50
1:I:132:TRP:HA	1:I:176:TRP:CH2	2.47	0.50
1:E:11:ASN:HD22	1:E:232:SER:HB3	1.77	0.49
1:L:22:VAL:HG22	1:L:240:LEU:HD22	1.93	0.49
1:D:47:ALA:HB3	1:D:83:HIS:CD2	2.48	0.49
1:H:5:LEU:HD12	1:H:37:GLU:O	2.12	0.49
1:I:129:LEU:HG	1:I:133:ASP:HB2	1.95	0.49
1:J:25:GLU:HA	1:J:28:ARG:NH1	2.27	0.49
1:K:131:PRO:HG3	4:L:304:HOH:O	2.12	0.49
1:B:154:ARG:HH11	3:B:268:PEP:P	2.35	0.49
1:C:224:HIS:ND1	1:C:225:PRO:HD2	2.27	0.49
1:F:41:LYS:HD3	1:F:41:LYS:C	2.33	0.49
1:H:240:LEU:O	1:H:243:LEU:HD23	2.12	0.49
1:I:122:ASN:HA	1:I:150:TYR:HB2	1.93	0.49
1:K:22:VAL:O	1:K:26:ILE:HG12	2.12	0.49
1:D:78:ILE:N	1:D:96:ASP:OD2	2.43	0.49
1:I:116:LYS:HG3	1:I:116:LYS:O	2.12	0.49
1:K:258:SER:HA	1:K:261:TYR:CE2	2.48	0.49
1:D:242:GLN:O	1:D:246:ILE:HD13	2.13	0.49

Continued on next page...

Continued from previous page...

Atom-1	Atom-2	Interatomic distance (Å)	Clash overlap (Å)
1:E:58:HIS:O	1:E:62:TYR:HB3	2.12	0.49
1:A:214:VAL:HG23	1:D:210:ALA:HB2	1.94	0.49
1:E:205:PHE:HB3	1:E:206:PRO:HD3	1.95	0.49
1:K:106:ARG:O	1:L:48:ASN:HA	2.13	0.49
1:A:50:SER:O	1:B:136:ASN:HB3	2.12	0.49
1:I:11:ASN:HD21	1:I:46:LYS:CE	2.25	0.49
1:L:212:VAL:HG11	1:L:250:ILE:HB	1.95	0.49
1:C:11:ASN:ND2	1:C:232:SER:OG	2.46	0.49
1:I:40:PHE:HB3	1:I:78:ILE:HD13	1.94	0.49
1:A:180:ILE:N	1:A:180:ILE:HD12	2.27	0.48
1:A:256:VAL:CG2	1:D:252:GLU:HB3	2.43	0.48
1:C:183:ALA:HB2	1:C:208:ILE:HG12	1.95	0.48
1:F:223:THR:OG1	1:F:240:LEU:HA	2.12	0.48
1:F:256:VAL:HG21	1:G:256:VAL:CG1	2.42	0.48
1:J:46:LYS:HB2	1:J:56:ARG:HA	1.94	0.48
1:K:138:VAL:HG13	1:K:149:ILE:CD1	2.42	0.48
1:D:254:ARG:O	1:D:258:SER:HB3	2.13	0.48
1:A:182:ASP:HA	1:A:220:PHE:HB3	1.96	0.48
1:D:137:VAL:HG22	4:D:311:HOH:O	2.12	0.48
1:D:161:ASN:ND2	1:D:190:PRO:O	2.45	0.48
1:F:256:VAL:CG2	1:G:256:VAL:HG11	2.42	0.48
1:A:100:ILE:HD12	1:A:111:LEU:HD12	1.95	0.48
1:B:89:GLU:N	1:B:90:PRO:HD2	2.28	0.48
1:C:41:LYS:HD2	1:C:42:SER:N	2.28	0.48
1:H:247:ILE:O	1:H:250:ILE:HG12	2.12	0.48
1:I:204:ILE:HD13	1:I:238:LEU:CD1	2.44	0.48
1:K:19:LEU:HD23	1:K:19:LEU:C	2.34	0.48
1:A:150:TYR:HB3	1:A:180:ILE:HD13	1.96	0.48
1:B:87:GLN:O	1:B:90:PRO:HG2	2.12	0.48
1:F:41:LYS:HB2	1:F:79:THR:CG2	2.43	0.48
1:J:100:ILE:HG12	1:J:111:LEU:HD23	1.95	0.48
1:C:40:PHE:HB3	1:C:78:ILE:HD13	1.95	0.48
1:I:147:LYS:HE3	4:I:353:HOH:O	2.13	0.48
1:J:263:THR:HG22	1:J:263:THR:O	2.14	0.48
1:K:6:VAL:HG12	1:K:6:VAL:O	2.13	0.48
1:C:68:ARG:O	1:C:72:GLU:HG3	2.14	0.48
1:G:261:TYR:O	1:G:263:THR:HG23	2.13	0.48
1:I:184:THR:CG2	1:I:222:GLU:H	2.20	0.48
1:J:135:LYS:NZ	4:J:337:HOH:O	2.45	0.48
1:K:212:VAL:HG23	1:K:253:ILE:CG2	2.44	0.48
1:E:13:ILE:HD12	1:E:44:PHE:HA	1.95	0.48

Continued on next page...

Continued from previous page...

Atom-1	Atom-2	Interatomic distance (Å)	Clash overlap (Å)
1:F:77:LYS:NZ	1:F:77:LYS:HB3	2.29	0.48
1:H:68:ARG:O	1:H:72:GLU:HG3	2.14	0.48
1:H:204:ILE:O	1:H:208:ILE:HG13	2.14	0.48
1:H:249:ALA:O	1:H:253:ILE:HG12	2.13	0.48
1:K:7:ILE:H	1:K:7:ILE:CD1	2.24	0.48
1:L:184:THR:HG22	1:L:204:ILE:HD13	1.94	0.48
1:L:212:VAL:HG23	1:L:253:ILE:CG2	2.44	0.48
1:D:200:MET:HG2	4:D:305:HOH:O	2.14	0.48
1:H:132:TRP:HA	1:H:176:TRP:CH2	2.49	0.48
1:E:224:HIS:ND1	1:E:225:PRO:HD2	2.29	0.47
1:F:15:SER:HB2	1:F:18:LEU:CB	2.39	0.47
1:G:175:GLN:HG2	1:G:264:ILE:HG12	1.96	0.47
1:H:184:THR:CG2	1:H:221:MET:HA	2.44	0.47
1:L:233:ASP:HB3	1:L:236:THR:OG1	2.14	0.47
1:A:203:PHE:C	1:A:206:PRO:HD2	2.34	0.47
1:D:3:LYS:HD2	1:D:37:GLU:HB2	1.96	0.47
1:E:41:LYS:HD3	1:E:42:SER:N	2.29	0.47
1:E:200:MET:HB3	1:E:202:GLU:OE1	2.14	0.47
1:G:195:ASP:HB2	1:H:136:ASN:OD1	2.14	0.47
1:I:131:PRO:HD3	1:J:160:TYR:CE1	2.50	0.47
1:K:238:LEU:HD12	1:K:239:PRO:HD2	1.96	0.47
1:L:60:LEU:HD23	1:L:60:LEU:O	2.14	0.47
1:L:138:VAL:HG21	1:L:176:TRP:CD1	2.49	0.47
1:E:250:ILE:HD12	1:E:250:ILE:C	2.35	0.47
1:K:82:ILE:HD13	1:K:82:ILE:H	1.79	0.47
1:L:92:ALA:CB	1:L:117:THR:HB	2.44	0.47
1:L:200:MET:HA	4:L:326:HOH:O	2.14	0.47
1:G:25:GLU:HA	1:G:25:GLU:OE1	2.15	0.47
1:D:264:ILE:H	1:D:264:ILE:CD1	2.18	0.47
1:E:264:ILE:HG22	4:E:277:HOH:O	2.15	0.47
1:F:7:ILE:CD1	1:F:39:VAL:HB	2.43	0.47
1:H:13:ILE:HD11	1:H:42:SER:HB3	1.95	0.47
1:H:240:LEU:HA	1:H:243:LEU:CD2	2.45	0.47
1:I:130:ALA:HB3	1:I:133:ASP:OD2	2.15	0.47
1:I:187:VAL:HG21	1:I:204:ILE:HG12	1.96	0.47
1:E:172:ILE:HD11	1:H:203:PHE:HZ	1.79	0.47
1:F:60:LEU:C	1:F:60:LEU:HD23	2.35	0.47
1:H:150:TYR:CD1	1:H:178:LYS:HB2	2.49	0.47
1:C:250:ILE:C	1:C:250:ILE:HD12	2.34	0.47
1:F:8:ALA:HA	1:F:221:MET:O	2.14	0.47
1:G:41:LYS:HD3	1:G:41:LYS:C	2.35	0.47

Continued on next page...

Continued from previous page...

Atom-1	Atom-2	Interatomic distance (Å)	Clash overlap (Å)
1:H:240:LEU:HA	1:H:243:LEU:HD23	1.97	0.47
1:H:243:LEU:O	1:H:247:ILE:HG12	2.14	0.47
1:L:157:THR:HG23	4:L:282:HOH:O	2.15	0.47
1:C:47:ALA:HB3	1:C:83:HIS:CD2	2.50	0.47
1:C:97:ILE:CD1	1:C:120:ALA:HB3	2.40	0.47
1:F:78:ILE:HG22	1:F:79:THR:N	2.30	0.47
1:J:203:PHE:C	1:J:206:PRO:HD2	2.35	0.47
1:L:106:ARG:HG3	1:L:106:ARG:NH1	2.30	0.47
1:B:204:ILE:O	1:B:208:ILE:HG13	2.15	0.47
1:D:210:ALA:O	1:D:214:VAL:HG23	2.14	0.47
1:F:176:TRP:O	1:F:177:ALA:HB2	2.15	0.47
1:K:28:ARG:HH22	1:K:244:GLU:CD	2.18	0.47
1:K:88:ALA:HB1	1:K:113:ALA:O	2.15	0.47
1:A:136:ASN:HB3	1:B:50:SER:O	2.15	0.47
1:B:151:LEU:CB	1:B:173:MET:HE2	2.44	0.47
1:D:223:THR:CG2	1:D:243:LEU:HD11	2.41	0.47
1:D:234:ALA:HB3	4:D:315:HOH:O	2.14	0.47
1:H:154:ARG:HD2	3:H:268:PEP:O3P	2.14	0.47
1:I:10:MET:HE2	1:I:14:GLU:HG3	1.96	0.47
1:B:213:ALA:O	1:C:209:ARG:HD2	2.15	0.46
1:E:219:VAL:HG12	1:E:220:PHE:N	2.31	0.46
1:J:10:MET:HE2	1:J:14:GLU:HG3	1.97	0.46
1:J:227:PRO:HG2	1:J:239:PRO:HG3	1.96	0.46
1:K:67:LEU:O	1:K:70:VAL:HG12	2.15	0.46
1:K:69:LYS:HA	1:K:72:GLU:HG2	1.96	0.46
1:C:205:PHE:HB3	1:C:206:PRO:HD3	1.98	0.46
1:E:189:LEU:HG	1:E:199:GLY:HA2	1.96	0.46
1:E:233:ASP:O	1:E:237:GLN:HG2	2.15	0.46
1:F:174:LYS:HE3	1:F:215:GLY:O	2.15	0.46
1:F:223:THR:HG21	1:F:243:LEU:HD12	1.97	0.46
1:J:184:THR:CG2	1:J:222:GLU:H	2.28	0.46
1:K:19:LEU:HD23	1:K:19:LEU:O	2.15	0.46
1:K:52:ILE:HB	1:L:140:LYS:HG2	1.97	0.46
1:K:170:LEU:CB	1:K:171:PRO:HD3	2.45	0.46
1:L:47:ALA:HB3	1:L:83:HIS:CD2	2.50	0.46
1:L:117:THR:C	1:L:119:ARG:H	2.18	0.46
1:A:27:LYS:HD3	1:A:74:PHE:O	2.15	0.46
1:G:4:PHE:CE2	1:G:250:ILE:HD13	2.50	0.46
1:G:60:LEU:C	1:G:60:LEU:HD23	2.36	0.46
1:J:264:ILE:HG23	1:J:264:ILE:OXT	2.15	0.46
1:K:97:ILE:HD12	1:K:97:ILE:N	2.30	0.46

Continued on next page...

Continued from previous page...

Atom-1	Atom-2	Interatomic distance (Å)	Clash overlap (Å)
1:I:154:ARG:HD2	3:I:268:PEP:O3P	2.15	0.46
1:L:91:VAL:C	1:L:93:GLU:H	2.18	0.46
1:F:34:LYS:HB2	1:F:34:LYS:NZ	2.30	0.46
1:G:9:GLY:O	1:G:222:GLU:HA	2.16	0.46
1:D:41:LYS:HD3	1:D:42:SER:N	2.31	0.46
1:D:62:TYR:O	1:D:62:TYR:CD2	2.68	0.46
1:E:5:LEU:HD22	1:E:7:ILE:HG12	1.96	0.46
1:F:10:MET:O	1:F:42:SER:HA	2.15	0.46
1:K:52:ILE:O	1:K:52:ILE:HD13	2.16	0.46
1:K:130:ALA:O	1:K:133:ASP:HB2	2.15	0.46
1:L:11:ASN:HD21	1:L:46:LYS:HE2	1.80	0.46
1:B:10:MET:HG3	1:B:22:VAL:HG21	1.98	0.46
1:E:78:ILE:HG22	1:E:79:THR:N	2.31	0.46
1:F:97:ILE:HG12	1:F:120:ALA:HB3	1.98	0.46
1:J:228:GLU:CD	1:J:228:GLU:H	2.18	0.46
1:A:5:LEU:HD12	1:A:37:GLU:O	2.16	0.46
1:B:9:GLY:HA3	1:B:41:LYS:O	2.15	0.46
1:J:30:SER:HA	1:J:38:PHE:CE2	2.50	0.46
1:K:24:GLU:HA	1:K:74:PHE:CE1	2.51	0.46
1:A:25:GLU:HG2	1:A:240:LEU:HG	1.97	0.46
1:E:99:GLN:C	1:E:100:ILE:HD12	2.36	0.46
1:G:262:GLU:CD	1:G:262:GLU:H	2.19	0.46
1:H:13:ILE:HB	4:H:306:HOH:O	2.15	0.46
1:L:27:LYS:HA	1:L:76:LEU:HD21	1.97	0.46
1:L:82:ILE:HD11	1:L:100:ILE:HD13	1.97	0.46
1:D:22:VAL:O	1:D:26:ILE:HG12	2.16	0.46
1:F:233:ASP:O	1:F:237:GLN:HG2	2.16	0.46
1:J:220:PHE:C	1:J:220:PHE:CD2	2.89	0.46
1:A:89:GLU:HB3	1:A:90:PRO:CD	2.46	0.45
1:A:239:PRO:HG2	1:A:242:GLN:HE21	1.81	0.45
1:K:46:LYS:HB2	1:K:56:ARG:HA	1.98	0.45
1:F:201:ARG:NH1	1:F:235:SER:O	2.49	0.45
1:K:41:LYS:NZ	1:K:220:PHE:HZ	2.15	0.45
1:K:47:ALA:HB2	1:K:56:ARG:HH21	1.81	0.45
1:K:138:VAL:HG13	1:K:149:ILE:HD12	1.98	0.45
1:B:227:PRO:HG3	1:B:239:PRO:HG3	1.99	0.45
1:C:223:THR:HA	1:C:238:LEU:O	2.15	0.45
1:D:97:ILE:HA	1:D:120:ALA:O	2.17	0.45
1:D:98:ILE:N	1:D:120:ALA:O	2.48	0.45
1:K:230:ALA:HB3	1:K:234:ALA:HB2	1.98	0.45
1:E:17:GLU:O	1:E:17:GLU:HG2	2.16	0.45

Continued on next page...

Continued from previous page...

Atom-1	Atom-2	Interatomic distance (Å)	Clash overlap (Å)
1:I:212:VAL:HG21	1:I:250:ILE:HB	1.97	0.45
1:K:60:LEU:C	1:K:60:LEU:HD23	2.37	0.45
1:K:184:THR:CG2	1:K:222:GLU:H	2.28	0.45
1:K:219:VAL:HG21	1:K:221:MET:HE3	1.99	0.45
1:L:4:PHE:HZ	1:L:219:VAL:HG23	1.80	0.45
1:B:41:LYS:HD3	1:B:41:LYS:C	2.37	0.45
1:C:66:ALA:O	1:C:70:VAL:HG23	2.16	0.45
1:C:81:ASP:HA	1:C:99:GLN:O	2.16	0.45
1:F:29:LEU:HD22	1:F:33:PHE:HE2	1.81	0.45
1:F:224:HIS:O	1:F:227:PRO:HD3	2.17	0.45
1:I:169:SER:O	1:I:173:MET:HG3	2.17	0.45
1:K:22:VAL:HG12	1:K:40:PHE:HE1	1.82	0.45
1:B:102:ALA:HB2	1:B:154:ARG:HD3	1.99	0.45
1:D:102:ALA:HB2	1:D:154:ARG:HD3	1.98	0.45
1:E:16:GLU:OE2	1:E:69:LYS:HD3	2.16	0.45
1:E:247:ILE:O	1:E:250:ILE:HG13	2.17	0.45
1:H:46:LYS:HB3	1:H:49:ARG:HD3	1.97	0.45
1:K:41:LYS:HD3	1:K:41:LYS:C	2.37	0.45
1:I:208:ILE:O	1:I:212:VAL:HG23	2.17	0.45
1:J:157:THR:HG23	4:J:309:HOH:O	2.16	0.45
1:J:184:THR:HG23	1:J:221:MET:HA	1.99	0.45
1:F:16:GLU:CD	1:F:66:ALA:HA	2.37	0.45
1:G:25:GLU:HG2	1:G:240:LEU:HG	1.99	0.45
1:L:82:ILE:HD12	1:L:98:ILE:CG2	2.47	0.45
1:E:102:ALA:HA	1:E:124:LYS:O	2.16	0.45
1:E:189:LEU:HD13	4:E:284:HOH:O	2.16	0.45
1:F:141:LEU:HD13	1:F:149:ILE:HD12	1.99	0.45
1:G:60:LEU:O	1:G:64:VAL:HG23	2.17	0.45
1:J:154:ARG:HD2	3:J:268:PEP:O3P	2.17	0.45
1:L:212:VAL:HG23	1:L:253:ILE:HG21	1.99	0.45
1:L:263:THR:O	1:L:264:ILE:HG12	2.17	0.45
1:B:238:LEU:HA	1:B:239:PRO:HD3	1.88	0.44
1:D:79:THR:OG1	1:D:97:ILE:O	2.25	0.44
1:K:89:GLU:HB2	1:K:90:PRO:HD3	1.99	0.44
1:K:212:VAL:HG23	1:K:253:ILE:HG21	1.98	0.44
1:C:11:ASN:HD21	1:C:46:LYS:HE2	1.82	0.44
1:G:195:ASP:HA	1:H:136:ASN:HD21	1.82	0.44
1:J:130:ALA:HB3	1:J:133:ASP:OD2	2.17	0.44
1:B:246:ILE:O	1:B:250:ILE:HG13	2.17	0.44
1:E:91:VAL:C	1:E:93:GLU:N	2.70	0.44
1:I:102:ALA:HB2	1:I:154:ARG:HD3	2.00	0.44

Continued on next page...

Continued from previous page...

Atom-1	Atom-2	Interatomic distance (Å)	Clash overlap (Å)
1:J:172:ILE:O	1:J:175:GLN:HG3	2.17	0.44
1:L:131:PRO:HG3	1:L:169:SER:HB3	1.99	0.44
1:A:81:ASP:HA	1:A:99:GLN:O	2.18	0.44
1:A:150:TYR:HB3	1:A:180:ILE:CD1	2.48	0.44
1:E:11:ASN:ND2	1:E:232:SER:HB3	2.32	0.44
1:F:138:VAL:HG11	1:F:176:TRP:O	2.17	0.44
1:J:18:LEU:O	1:J:22:VAL:HG23	2.17	0.44
1:J:239:PRO:HD2	1:J:242:GLN:NE2	2.33	0.44
1:K:97:ILE:HA	1:K:120:ALA:HB3	1.99	0.44
1:F:64:VAL:HG12	1:F:68:ARG:NH1	2.33	0.44
1:F:212:VAL:HG11	1:F:250:ILE:HG23	2.00	0.44
1:H:4:PHE:CE2	1:H:250:ILE:HD12	2.52	0.44
1:H:58:HIS:HB2	1:H:62:TYR:CD2	2.51	0.44
1:K:100:ILE:N	1:K:100:ILE:HD12	2.33	0.44
1:E:135:LYS:HE3	4:E:288:HOH:O	2.17	0.44
1:G:40:PHE:HB3	1:G:78:ILE:HD13	1.99	0.44
1:K:128:PHE:HB3	4:L:270:HOH:O	2.16	0.44
1:K:212:VAL:CG1	1:K:250:ILE:HG23	2.40	0.44
1:A:239:PRO:HD2	1:A:242:GLN:NE2	2.33	0.44
1:C:4:PHE:CE1	1:C:218:GLY:HA2	2.53	0.44
1:C:72:GLU:HA	4:C:322:HOH:O	2.17	0.44
1:C:108:THR:O	1:C:112:LEU:HB2	2.18	0.44
1:E:213:ALA:O	1:H:209:ARG:HD2	2.18	0.44
1:F:157:THR:HG23	4:F:299:HOH:O	2.17	0.44
1:G:60:LEU:HD23	1:G:60:LEU:O	2.17	0.44
1:G:224:HIS:ND1	1:G:225:PRO:HD2	2.33	0.44
1:C:238:LEU:HD21	1:C:246:ILE:CD1	2.45	0.44
1:C:14:GLU:OE2	1:C:231:LEU:HG	2.17	0.44
1:I:252:GLU:O	1:I:255:GLU:HB3	2.18	0.44
1:J:41:LYS:HD3	1:J:42:SER:N	2.33	0.44
1:A:223:THR:HG21	1:A:243:LEU:HD11	1.99	0.43
1:B:49:ARG:HH11	3:B:269:PEP:P	2.41	0.43
1:C:116:LYS:HD3	4:C:305:HOH:O	2.17	0.43
1:C:116:LYS:O	1:C:118:GLY:N	2.51	0.43
1:E:16:GLU:OE2	1:E:65:LYS:HE3	2.18	0.43
1:G:13:ILE:O	1:G:13:ILE:HG22	2.18	0.43
1:K:170:LEU:HB2	1:K:171:PRO:HD3	1.98	0.43
1:L:87:GLN:O	1:L:91:VAL:HG23	2.17	0.43
1:E:87:GLN:C	1:E:90:PRO:HD2	2.38	0.43
1:F:106:ARG:HG3	1:F:106:ARG:NH1	2.34	0.43
1:F:214:VAL:CG2	1:G:210:ALA:HB2	2.49	0.43

Continued on next page...

Continued from previous page...

Atom-1	Atom-2	Interatomic distance (Å)	Clash overlap (Å)
1:F:256:VAL:CG1	1:G:252:GLU:HB3	2.48	0.43
1:K:56:ARG:NH2	1:L:109:ASP:OD2	2.46	0.43
1:K:100:ILE:HD13	1:K:121:VAL:HG13	1.98	0.43
1:K:122:ASN:HA	1:K:150:TYR:HB2	2.00	0.43
1:K:202:GLU:HB3	4:K:1499:HOH:O	2.18	0.43
1:E:52:ILE:O	1:E:52:ILE:HG13	2.17	0.43
1:F:242:GLN:O	1:F:246:ILE:HD13	2.18	0.43
1:I:247:ILE:O	1:I:250:ILE:HG12	2.17	0.43
1:L:60:LEU:HD23	1:L:60:LEU:C	2.38	0.43
1:A:150:TYR:HD1	1:A:180:ILE:HD11	1.78	0.43
1:A:180:ILE:HG22	1:A:181:TYR:N	2.34	0.43
1:F:170:LEU:CB	1:F:171:PRO:HD3	2.46	0.43
1:G:188:GLN:HA	1:G:199:GLY:HA3	1.99	0.43
1:H:13:ILE:HG12	1:H:43:SER:O	2.18	0.43
1:K:82:ILE:HD12	1:K:98:ILE:CG2	2.49	0.43
1:C:87:GLN:O	1:C:91:VAL:HG23	2.17	0.43
1:D:122:ASN:HA	1:D:150:TYR:HB2	2.01	0.43
1:G:24:GLU:HA	1:G:74:PHE:CE1	2.54	0.43
1:I:136:ASN:HB3	1:J:50:SER:O	2.19	0.43
1:J:210:ALA:O	1:J:214:VAL:HG23	2.18	0.43
1:H:18:LEU:O	1:H:22:VAL:HG23	2.19	0.43
1:I:183:ALA:CB	1:I:208:ILE:HG12	2.47	0.43
1:J:78:ILE:CG2	1:J:79:THR:N	2.82	0.43
1:J:205:PHE:HB3	1:J:206:PRO:HD3	2.01	0.43
1:K:129:LEU:HD23	4:K:1155:HOH:O	2.18	0.43
1:A:71:LYS:HE3	1:A:78:ILE:HG12	2.01	0.43
1:A:140:LYS:HE3	1:B:50:SER:O	2.18	0.43
1:J:4:PHE:HZ	1:J:219:VAL:HG23	1.83	0.43
1:J:196:LYS:HB3	1:J:197:SER:H	1.73	0.43
1:L:19:LEU:HD23	1:L:66:ALA:HB1	2.01	0.43
1:L:208:ILE:HG22	1:L:250:ILE:CG2	2.49	0.43
1:L:243:LEU:HD12	1:L:243:LEU:HA	1.78	0.43
1:A:132:TRP:HA	1:A:176:TRP:CH2	2.53	0.43
1:E:262:GLU:OE1	1:H:209:ARG:NH2	2.49	0.43
1:H:41:LYS:C	1:H:41:LYS:HD3	2.39	0.43
1:H:41:LYS:HD3	1:H:42:SER:N	2.33	0.43
1:I:246:ILE:O	1:I:250:ILE:HG23	2.18	0.43
4:I:270:HOH:O	1:J:128:PHE:HB3	2.19	0.43
1:K:89:GLU:N	1:K:90:PRO:CD	2.81	0.43
1:L:187:VAL:HG21	1:L:204:ILE:CG1	2.49	0.43
1:A:129:LEU:HG	1:A:133:ASP:HB2	2.01	0.43

Continued on next page...

Continued from previous page...

Atom-1	Atom-2	Interatomic distance (Å)	Clash overlap (Å)
1:B:130:ALA:HB3	1:B:133:ASP:OD2	2.19	0.43
1:B:154:ARG:HD2	3:B:268:PEP:O3P	2.18	0.43
1:F:98:ILE:HD12	1:F:98:ILE:N	2.33	0.43
1:I:41:LYS:HD3	1:I:42:SER:N	2.34	0.43
1:A:35:GLU:OE1	1:A:35:GLU:N	2.33	0.43
1:H:183:ALA:HB2	1:H:208:ILE:HG12	2.00	0.43
1:L:87:GLN:C	1:L:90:PRO:HD2	2.39	0.43
1:L:227:PRO:HG3	1:L:239:PRO:HG3	2.01	0.43
1:A:246:ILE:N	1:A:246:ILE:HD12	2.34	0.42
1:D:78:ILE:HG22	1:D:79:THR:N	2.34	0.42
1:D:174:LYS:HE3	1:D:174:LYS:HB2	1.86	0.42
1:G:102:ALA:HB2	1:G:154:ARG:HD3	2.00	0.42
1:I:154:ARG:HH22	1:I:188:GLN:HE21	1.66	0.42
1:J:41:LYS:HD3	1:J:41:LYS:C	2.39	0.42
1:A:30:SER:HA	1:A:38:PHE:CD2	2.55	0.42
1:A:135:LYS:HG2	4:A:355:HOH:O	2.19	0.42
1:C:152:THR:OG1	1:C:180:ILE:HB	2.19	0.42
1:F:29:LEU:HD13	1:F:247:ILE:HD12	2.02	0.42
1:H:41:LYS:HB2	1:H:79:THR:CG2	2.48	0.42
1:C:128:PHE:HB3	4:C:270:HOH:O	2.19	0.42
1:E:18:LEU:HD12	1:E:18:LEU:HA	1.93	0.42
1:F:64:VAL:O	1:F:68:ARG:HG3	2.19	0.42
1:I:4:PHE:HB2	1:I:254:ARG:NH1	2.34	0.42
1:I:168:ARG:O	1:I:172:ILE:HG13	2.19	0.42
1:J:122:ASN:HA	1:J:150:TYR:HB2	2.01	0.42
1:L:128:PHE:HB3	4:L:270:HOH:O	2.19	0.42
1:L:205:PHE:N	1:L:206:PRO:CD	2.82	0.42
1:F:78:ILE:HB	1:F:94:VAL:O	2.18	0.42
1:F:88:ALA:HB2	1:F:113:ALA:HB1	2.01	0.42
1:J:13:ILE:HG23	1:J:19:LEU:HD22	2.01	0.42
1:K:18:LEU:O	1:K:18:LEU:HD23	2.20	0.42
1:K:239:PRO:HG2	1:K:242:GLN:NE2	2.33	0.42
1:B:26:ILE:HD12	1:B:40:PHE:CD1	2.54	0.42
1:D:27:LYS:O	1:D:30:SER:HB3	2.18	0.42
1:D:70:VAL:HG13	1:D:74:PHE:HD2	1.84	0.42
1:E:112:LEU:O	1:E:116:LYS:HG2	2.18	0.42
1:F:212:VAL:HG23	1:F:253:ILE:CG2	2.49	0.42
1:L:4:PHE:O	1:L:36:VAL:HG13	2.19	0.42
1:L:182:ASP:HA	1:L:220:PHE:HB3	2.01	0.42
1:D:10:MET:O	1:D:42:SER:HA	2.19	0.42
1:D:36:VAL:CG2	1:D:251:LEU:HD21	2.49	0.42

Continued on next page...

Continued from previous page...

Atom-1	Atom-2	Interatomic distance (Å)	Clash overlap (Å)
1:H:233:ASP:OD1	3:H:269:PEP:H31	2.20	0.42
1:L:60:LEU:O	1:L:64:VAL:HG23	2.19	0.42
1:A:27:LYS:HD3	1:A:74:PHE:HB3	2.01	0.42
1:A:58:HIS:HB3	1:G:143:PHE:HA	2.00	0.42
1:B:11:ASN:HD21	1:B:46:LYS:CE	2.33	0.42
1:D:239:PRO:HG2	1:D:242:GLN:HG3	2.02	0.42
1:E:87:GLN:O	1:E:91:VAL:HG22	2.20	0.42
1:I:154:ARG:HH22	1:I:188:GLN:NE2	2.18	0.42
1:L:187:VAL:HG21	1:L:204:ILE:HG12	2.01	0.42
1:A:130:ALA:HB3	1:A:133:ASP:OD2	2.19	0.42
1:C:117:THR:C	1:C:119:ARG:H	2.23	0.42
1:F:16:GLU:O	1:F:20:LEU:HG	2.17	0.42
1:F:113:ALA:O	1:F:117:THR:HG23	2.20	0.42
1:H:168:ARG:O	1:H:172:ILE:HG13	2.20	0.42
1:I:3:LYS:HG3	1:I:35:GLU:O	2.20	0.42
1:J:158:PHE:HB2	1:J:164:VAL:HG12	2.02	0.42
1:C:116:LYS:C	1:C:118:GLY:N	2.73	0.42
1:D:154:ARG:HD2	3:D:268:PEP:O3P	2.20	0.42
1:H:179:VAL:C	1:H:180:ILE:HD12	2.40	0.42
1:J:5:LEU:HD11	1:J:39:VAL:HG23	2.01	0.42
1:L:208:ILE:HG22	1:L:250:ILE:HG21	2.01	0.42
1:B:151:LEU:HB3	1:B:173:MET:HE3	2.02	0.42
1:E:240:LEU:O	1:E:243:LEU:HD13	2.19	0.42
1:G:227:PRO:HG2	1:G:239:PRO:HG3	2.01	0.42
1:B:35:GLU:HB2	4:B:272:HOH:O	2.20	0.41
1:D:147:LYS:HG2	4:D:318:HOH:O	2.18	0.41
1:E:68:ARG:NH1	1:E:68:ARG:HB2	2.34	0.41
1:F:78:ILE:HB	1:F:95:ALA:HA	2.01	0.41
1:A:135:LYS:HD2	1:A:176:TRP:NE1	2.35	0.41
1:C:91:VAL:C	1:C:93:GLU:H	2.23	0.41
1:E:243:LEU:HD12	1:E:243:LEU:N	2.34	0.41
1:F:5:LEU:N	1:F:5:LEU:HD12	2.35	0.41
1:I:60:LEU:C	1:I:60:LEU:HD23	2.41	0.41
1:I:132:TRP:HA	1:I:176:TRP:HH2	1.85	0.41
1:J:152:THR:CG2	1:J:182:ASP:HB2	2.50	0.41
1:D:116:LYS:C	1:D:118:GLY:H	2.24	0.41
1:G:30:SER:HA	1:G:38:PHE:CD2	2.55	0.41
1:H:233:ASP:H	3:H:269:PEP:C1	2.34	0.41
1:J:105:CYS:SG	1:J:129:LEU:HD22	2.59	0.41
1:K:11:ASN:ND2	1:K:46:LYS:HE2	2.31	0.41
1:K:138:VAL:HG12	1:K:142:LYS:HE3	2.02	0.41

Continued on next page...

Continued from previous page...

Atom-1	Atom-2	Interatomic distance (Å)	Clash overlap (Å)
1:D:165:VAL:CG2	1:D:186:SER:HB3	2.50	0.41
1:H:49:ARG:NH1	1:H:54:SER:HB3	2.35	0.41
1:H:242:GLN:O	1:H:246:ILE:HG12	2.19	0.41
1:D:89:GLU:OE2	1:D:117:THR:HG22	2.19	0.41
1:D:257:ALA:O	1:D:258:SER:C	2.59	0.41
1:E:47:ALA:HB3	1:E:83:HIS:CD2	2.55	0.41
1:I:64:VAL:HG13	1:I:94:VAL:CG1	2.50	0.41
1:C:35:GLU:OE1	1:C:35:GLU:N	2.50	0.41
1:D:19:LEU:O	1:D:19:LEU:HD13	2.21	0.41
1:F:59:GLY:HA2	4:F:317:HOH:O	2.20	0.41
1:J:18:LEU:HD12	1:J:18:LEU:HA	1.90	0.41
1:J:212:VAL:HG21	1:J:250:ILE:CB	2.46	0.41
1:K:242:GLN:O	1:K:246:ILE:HG12	2.21	0.41
1:B:49:ARG:HA	3:B:269:PEP:H32	2.03	0.41
1:E:92:ALA:HB2	1:E:98:ILE:HD11	2.02	0.41
1:F:219:VAL:HG22	1:F:220:PHE:N	2.35	0.41
1:G:227:PRO:HD2	4:G:367:HOH:O	2.20	0.41
1:A:4:PHE:HZ	1:A:219:VAL:HG13	1.86	0.41
1:A:78:ILE:HG22	1:A:79:THR:N	2.36	0.41
1:B:203:PHE:HE1	1:C:171:PRO:HG2	1.86	0.41
1:C:41:LYS:HD2	1:C:42:SER:H	1.86	0.41
1:C:264:ILE:HD12	1:C:264:ILE:C	2.41	0.41
1:D:204:ILE:HG21	1:D:238:LEU:HD21	2.03	0.41
1:G:11:ASN:HD21	1:G:46:LYS:HE2	1.86	0.41
1:H:69:LYS:HZ3	1:H:73:GLU:HB2	1.85	0.41
1:J:197:SER:HB2	2:J:269:PO4:P	2.61	0.41
1:L:154:ARG:HD2	3:L:268:PEP:O1P	2.21	0.41
1:C:21:LYS:HE3	1:C:21:LYS:HB2	1.92	0.41
1:D:208:ILE:HG22	1:D:250:ILE:HD12	2.02	0.41
1:D:247:ILE:O	1:D:251:LEU:HG	2.21	0.41
1:E:233:ASP:HB3	1:E:236:THR:OG1	2.20	0.41
1:F:4:PHE:CE2	1:F:250:ILE:HG21	2.56	0.41
1:G:238:LEU:HA	1:G:239:PRO:HD3	1.95	0.41
1:I:136:ASN:OD1	1:J:195:ASP:HA	2.21	0.41
1:K:208:ILE:HG21	1:K:250:ILE:HD11	2.02	0.41
1:K:226:GLU:OE2	1:K:226:GLU:HA	2.21	0.41
1:L:224:HIS:ND1	1:L:225:PRO:HD2	2.36	0.41
1:A:111:LEU:HD23	1:A:140:LYS:HD2	2.02	0.41
1:D:46:LYS:HB3	1:D:49:ARG:HD3	2.02	0.41
1:D:89:GLU:OE2	1:D:117:THR:HA	2.21	0.41
1:K:141:LEU:O	1:K:146:ALA:HB3	2.21	0.41

Continued on next page...

Continued from previous page...

Atom-1	Atom-2	Interatomic distance (Å)	Clash overlap (Å)
1:A:254:ARG:O	1:A:258:SER:HB3	2.21	0.40
1:E:104:LEU:O	1:E:106:ARG:N	2.54	0.40
1:F:3:LYS:HB2	1:F:35:GLU:O	2.21	0.40
1:F:65:LYS:HE3	1:F:65:LYS:HB2	1.91	0.40
1:I:10:MET:HE3	1:I:10:MET:HB2	1.87	0.40
1:J:246:ILE:HD12	1:J:246:ILE:N	2.35	0.40
1:K:94:VAL:HG22	1:K:94:VAL:O	2.22	0.40
1:K:212:VAL:HG21	1:K:253:ILE:HB	2.03	0.40
1:K:223:THR:HA	1:K:238:LEU:O	2.21	0.40
1:B:25:GLU:O	1:B:29:LEU:HG	2.21	0.40
1:B:127:GLN:OE1	1:B:127:GLN:N	2.54	0.40
1:C:78:ILE:HG22	1:C:79:THR:N	2.36	0.40
1:D:29:LEU:HD13	1:D:247:ILE:HD12	2.04	0.40
1:D:46:LYS:HA	1:D:46:LYS:CE	2.51	0.40
1:E:46:LYS:NZ	3:E:268:PEP:H31	2.36	0.40
1:E:140:LYS:HG2	1:F:52:ILE:HB	2.03	0.40
1:F:18:LEU:HD12	1:F:18:LEU:HA	1.93	0.40
1:F:97:ILE:HA	1:F:120:ALA:O	2.21	0.40
1:I:76:LEU:HA	4:I:293:HOH:O	2.21	0.40
1:J:239:PRO:HG2	1:J:242:GLN:NE2	2.36	0.40
1:K:41:LYS:HB2	1:K:79:THR:CG2	2.51	0.40
1:L:189:LEU:HA	1:L:190:PRO:HD2	1.96	0.40
1:L:223:THR:OG1	1:L:240:LEU:HA	2.21	0.40
1:A:205:PHE:HB3	1:A:206:PRO:HD3	2.02	0.40
1:C:251:LEU:HD23	1:C:251:LEU:HA	1.95	0.40
1:D:3:LYS:N	4:D:294:HOH:O	2.54	0.40
1:D:184:THR:CG2	1:D:222:GLU:H	2.33	0.40
1:K:264:ILE:N	1:K:264:ILE:CD1	2.84	0.40
1:L:20:LEU:HB2	4:L:285:HOH:O	2.21	0.40
1:L:181:TYR:OH	1:L:207:LEU:HB3	2.22	0.40
1:E:152:THR:HA	1:E:180:ILE:O	2.21	0.40
1:H:150:TYR:CD1	1:H:180:ILE:HD11	2.57	0.40
1:J:65:LYS:NZ	4:J:376:HOH:O	2.54	0.40
1:L:151:LEU:HD23	1:L:151:LEU:HA	1.98	0.40
1:B:5:LEU:HD12	1:B:37:GLU:O	2.22	0.40
1:C:203:PHE:C	1:C:206:PRO:HD2	2.41	0.40
1:E:50:SER:O	1:F:140:LYS:HE3	2.21	0.40
1:E:154:ARG:NH2	1:E:185:HIS:HB3	2.37	0.40
1:F:180:ILE:HA	1:F:218:GLY:O	2.21	0.40

There are no symmetry-related clashes.

5.3 Torsion angles [i](#)

5.3.1 Protein backbone [i](#)

In the following table, the Percentiles column shows the percent Ramachandran outliers of the chain as a percentile score with respect to all X-ray entries followed by that with respect to entries of similar resolution.

The Analysed column shows the number of residues for which the backbone conformation was analysed, and the total number of residues.

Mol	Chain	Analysed	Favoured	Allowed	Outliers	Percentiles	
1	A	253/263 (96%)	241 (95%)	12 (5%)	0	100	100
1	B	254/263 (97%)	245 (96%)	9 (4%)	0	100	100
1	C	253/263 (96%)	234 (92%)	15 (6%)	4 (2%)	9	9
1	D	252/263 (96%)	230 (91%)	17 (7%)	5 (2%)	7	6
1	E	252/263 (96%)	227 (90%)	22 (9%)	3 (1%)	13	14
1	F	251/263 (95%)	228 (91%)	23 (9%)	0	100	100
1	G	255/263 (97%)	245 (96%)	9 (4%)	1 (0%)	34	42
1	H	252/263 (96%)	242 (96%)	10 (4%)	0	100	100
1	I	260/263 (99%)	249 (96%)	11 (4%)	0	100	100
1	J	260/263 (99%)	245 (94%)	15 (6%)	0	100	100
1	K	253/263 (96%)	217 (86%)	31 (12%)	5 (2%)	7	6
1	L	252/263 (96%)	226 (90%)	23 (9%)	3 (1%)	13	14
All	All	3047/3156 (96%)	2829 (93%)	197 (6%)	21 (1%)	22	26

All (21) Ramachandran outliers are listed below:

Mol	Chain	Res	Type
1	D	262	GLU
1	K	94	VAL
1	C	85	SER
1	K	146	ALA
1	C	88	ALA
1	C	117	THR
1	D	117	THR
1	E	105	CYS
1	K	167	PHE
1	L	107	GLN
1	D	88	ALA
1	E	88	ALA

Continued on next page...

Continued from previous page...

Mol	Chain	Res	Type
1	K	192	GLY
1	L	92	ALA
1	C	87	GLN
1	D	61	GLU
1	D	92	ALA
1	E	92	ALA
1	K	48	ASN
1	L	228	GLU
1	G	262	GLU

5.3.2 Protein sidechains [i](#)

In the following table, the Percentiles column shows the percent sidechain outliers of the chain as a percentile score with respect to all X-ray entries followed by that with respect to entries of similar resolution.

The Analysed column shows the number of residues for which the sidechain conformation was analysed, and the total number of residues.

Mol	Chain	Analysed	Rotameric	Outliers	Percentiles
1	A	216/220 (98%)	212 (98%)	4 (2%)	57 73
1	B	216/220 (98%)	210 (97%)	6 (3%)	43 60
1	C	215/220 (98%)	213 (99%)	2 (1%)	78 89
1	D	215/220 (98%)	205 (95%)	10 (5%)	26 37
1	E	215/220 (98%)	207 (96%)	8 (4%)	34 48
1	F	215/220 (98%)	207 (96%)	8 (4%)	34 48
1	G	217/220 (99%)	208 (96%)	9 (4%)	30 43
1	H	215/220 (98%)	209 (97%)	6 (3%)	43 60
1	I	219/220 (100%)	215 (98%)	4 (2%)	59 75
1	J	219/220 (100%)	214 (98%)	5 (2%)	50 67
1	K	216/220 (98%)	209 (97%)	7 (3%)	39 54
1	L	215/220 (98%)	210 (98%)	5 (2%)	50 67
All	All	2593/2640 (98%)	2519 (97%)	74 (3%)	42 58

All (74) residues with a non-rotameric sidechain are listed below:

Mol	Chain	Res	Type
1	A	41	LYS

Continued on next page...

Continued from previous page...

Mol	Chain	Res	Type
1	A	111	LEU
1	A	207	LEU
1	A	264	ILE
1	B	21	LYS
1	B	42	SER
1	B	52	ILE
1	B	116	LYS
1	B	184	THR
1	B	188	GLN
1	C	31	GLU
1	C	154	ARG
1	D	3	LYS
1	D	5	LEU
1	D	19	LEU
1	D	52	ILE
1	D	62	TYR
1	D	82	ILE
1	D	176	TRP
1	D	237	GLN
1	D	248	GLU
1	D	264	ILE
1	E	17	GLU
1	E	35	GLU
1	E	61	GLU
1	E	72	GLU
1	E	116	LYS
1	E	119	ARG
1	E	154	ARG
1	E	244	GLU
1	F	52	ILE
1	F	77	LYS
1	F	148	GLU
1	F	176	TRP
1	F	188	GLN
1	F	200	MET
1	F	243	LEU
1	F	248	GLU
1	G	42	SER
1	G	200	MET
1	G	202	GLU
1	G	220	PHE
1	G	228	GLU

Continued on next page...

Continued from previous page...

Mol	Chain	Res	Type
1	G	233	ASP
1	G	238	LEU
1	G	248	GLU
1	G	250	ILE
1	H	52	ILE
1	H	154	ARG
1	H	184	THR
1	H	200	MET
1	H	238	LEU
1	H	264	ILE
1	I	21	LYS
1	I	52	ILE
1	I	61	GLU
1	I	200	MET
1	J	42	SER
1	J	78	ILE
1	J	154	ARG
1	J	220	PHE
1	J	248	GLU
1	K	41	LYS
1	K	52	ILE
1	K	82	ILE
1	K	124	LYS
1	K	176	TRP
1	K	237	GLN
1	K	264	ILE
1	L	5	LEU
1	L	69	LYS
1	L	82	ILE
1	L	154	ARG
1	L	237	GLN

Sometimes sidechains can be flipped to improve hydrogen bonding and reduce clashes. All (40) such sidechains are listed below:

Mol	Chain	Res	Type
1	A	11	ASN
1	A	242	GLN
1	B	11	ASN
1	B	175	GLN
1	B	185	HIS
1	B	188	GLN
1	B	237	GLN

Continued on next page...

Continued from previous page...

Mol	Chain	Res	Type
1	C	11	ASN
1	C	136	ASN
1	C	175	GLN
1	C	185	HIS
1	C	237	GLN
1	C	242	GLN
1	D	11	ASN
1	D	188	GLN
1	D	237	GLN
1	E	11	ASN
1	E	53	HIS
1	E	161	ASN
1	E	175	GLN
1	F	175	GLN
1	G	11	ASN
1	G	237	GLN
1	H	11	ASN
1	H	107	GLN
1	H	175	GLN
1	H	188	GLN
1	I	11	ASN
1	I	188	GLN
1	J	11	ASN
1	J	242	GLN
1	K	11	ASN
1	K	53	HIS
1	K	107	GLN
1	K	161	ASN
1	K	188	GLN
1	K	242	GLN
1	L	11	ASN
1	L	175	GLN
1	L	188	GLN

5.3.3 RNA [i](#)

There are no RNA molecules in this entry.

5.4 Non-standard residues in protein, DNA, RNA chains [i](#)

There are no non-standard protein/DNA/RNA residues in this entry.

5.5 Carbohydrates [i](#)

There are no monosaccharides in this entry.

5.6 Ligand geometry [i](#)

24 ligands are modelled in this entry.

In the following table, the Counts columns list the number of bonds (or angles) for which Mogul statistics could be retrieved, the number of bonds (or angles) that are observed in the model and the number of bonds (or angles) that are defined in the Chemical Component Dictionary. The Link column lists molecule types, if any, to which the group is linked. The Z score for a bond length (or angle) is the number of standard deviations the observed value is removed from the expected value. A bond length (or angle) with $|Z| > 2$ is considered an outlier worth inspection. RMSZ is the root-mean-square of all Z scores of the bond lengths (or angles).

Mol	Type	Chain	Res	Link	Bond lengths			Bond angles		
					Counts	RMSZ	# Z > 2	Counts	RMSZ	# Z > 2
3	PEP	E	268	-	9,9,9	1.16	1 (11%)	11,13,13	2.25	5 (45%)
3	PEP	J	268	-	9,9,9	0.96	0	11,13,13	1.75	2 (18%)
2	PO4	J	269	-	4,4,4	1.74	1 (25%)	6,6,6	0.43	0
3	PEP	G	269	-	9,9,9	1.29	1 (11%)	11,13,13	1.79	3 (27%)
2	PO4	A	269	-	4,4,4	1.57	0	6,6,6	0.45	0
3	PEP	F	268	-	9,9,9	1.13	0	11,13,13	1.85	3 (27%)
2	PO4	L	269	-	4,4,4	1.61	0	6,6,6	0.43	0
2	PO4	E	269	-	4,4,4	1.66	0	6,6,6	0.44	0
3	PEP	I	268	-	9,9,9	0.95	0	11,13,13	1.96	3 (27%)
3	PEP	I	269	-	9,9,9	1.05	0	11,13,13	2.59	2 (18%)
3	PEP	H	268	-	9,9,9	0.84	0	11,13,13	1.69	4 (36%)
3	PEP	C	269	-	9,9,9	1.15	1 (11%)	11,13,13	1.69	3 (27%)
3	PEP	K	268	-	9,9,9	1.06	0	11,13,13	1.09	1 (9%)
2	PO4	D	269	-	4,4,4	1.60	0	6,6,6	0.41	0
2	PO4	K	269	-	4,4,4	1.63	0	6,6,6	0.44	0
3	PEP	B	268	-	9,9,9	1.00	0	11,13,13	2.05	3 (27%)
3	PEP	G	268	-	9,9,9	1.21	0	11,13,13	2.12	4 (36%)
3	PEP	A	268	-	9,9,9	0.92	0	11,13,13	1.89	2 (18%)
3	PEP	C	268	-	9,9,9	1.07	0	11,13,13	1.25	1 (9%)
3	PEP	H	269	-	9,9,9	0.98	0	11,13,13	1.41	2 (18%)
3	PEP	B	269	-	9,9,9	1.53	2 (22%)	11,13,13	1.84	3 (27%)
3	PEP	L	268	-	9,9,9	1.00	0	11,13,13	1.61	3 (27%)
2	PO4	F	269	-	4,4,4	1.60	0	6,6,6	0.43	0

Mol	Type	Chain	Res	Link	Bond lengths			Bond angles		
					Counts	RMSZ	# Z > 2	Counts	RMSZ	# Z > 2
3	PEP	D	268	-	9,9,9	0.94	0	11,13,13	1.39	1 (9%)

In the following table, the Chirals column lists the number of chiral outliers, the number of chiral centers analysed, the number of these observed in the model and the number defined in the Chemical Component Dictionary. Similar counts are reported in the Torsion and Rings columns. '-' means no outliers of that kind were identified.

Mol	Type	Chain	Res	Link	Chirals	Torsions	Rings
3	PEP	B	268	-	-	4/9/9/9	-
3	PEP	E	268	-	-	0/9/9/9	-
3	PEP	G	268	-	-	0/9/9/9	-
3	PEP	A	268	-	-	0/9/9/9	-
3	PEP	F	268	-	-	4/9/9/9	-
3	PEP	C	268	-	-	4/9/9/9	-
3	PEP	H	269	-	-	4/9/9/9	-
3	PEP	J	268	-	-	5/9/9/9	-
3	PEP	I	268	-	-	4/9/9/9	-
3	PEP	I	269	-	-	4/9/9/9	-
3	PEP	H	268	-	-	0/9/9/9	-
3	PEP	G	269	-	-	4/9/9/9	-
3	PEP	C	269	-	-	7/9/9/9	-
3	PEP	B	269	-	-	0/9/9/9	-
3	PEP	L	268	-	-	4/9/9/9	-
3	PEP	D	268	-	-	4/9/9/9	-
3	PEP	K	268	-	-	5/9/9/9	-

All (6) bond length outliers are listed below:

Mol	Chain	Res	Type	Atoms	Z	Observed(Å)	Ideal(Å)
3	B	269	PEP	C2-C1	3.06	1.52	1.49
3	B	269	PEP	P-O2	2.34	1.62	1.59
3	G	269	PEP	C2-C1	2.32	1.51	1.49
2	J	269	PO4	P-O4	-2.11	1.48	1.54
3	C	269	PEP	P-O2	2.11	1.62	1.59
3	E	268	PEP	P-O2	2.02	1.62	1.59

All (45) bond angle outliers are listed below:

Mol	Chain	Res	Type	Atoms	Z	Observed(°)	Ideal(°)
3	I	269	PEP	O2'-C1-C2	6.47	124.94	113.91
3	I	268	PEP	O2'-C1-C2	4.93	122.33	113.91
3	G	268	PEP	O2'-C1-C2	4.82	122.14	113.91
3	J	268	PEP	O2'-C1-C2	4.49	121.57	113.91
3	I	269	PEP	O1-C1-C2	-4.22	115.42	121.79
3	E	268	PEP	O2'-C1-O1	-3.91	114.67	123.61
3	B	268	PEP	O2'-C1-C2	3.88	120.53	113.91
3	A	268	PEP	O2'-C1-C2	3.77	120.33	113.91
3	F	268	PEP	O2'-C1-C2	3.59	120.04	113.91
3	B	268	PEP	O2'-C1-O1	-3.54	115.51	123.61
3	C	269	PEP	O2-C2-C3	-3.53	117.99	124.79
3	E	268	PEP	O2'-C1-C2	3.53	119.93	113.91
3	E	268	PEP	O2-C2-C3	-3.47	118.10	124.79
3	B	268	PEP	O3P-P-O2P	3.43	120.74	107.64
3	B	269	PEP	O2'-C1-O1	-3.42	115.77	123.61
3	G	269	PEP	O2'-C1-C2	3.39	119.69	113.91
3	B	269	PEP	O2'-C1-C2	3.37	119.66	113.91
3	G	268	PEP	O3P-P-O2	-3.26	95.30	105.25
3	D	268	PEP	O2'-C1-C2	3.22	119.41	113.91
3	A	268	PEP	O3P-P-O2	-3.18	95.56	105.25
3	F	268	PEP	O2'-C1-O1	-3.12	116.46	123.61
3	L	268	PEP	O2'-C1-C2	3.06	119.14	113.91
3	G	269	PEP	O2'-C1-O1	-3.05	116.62	123.61
3	C	269	PEP	O2'-C1-C2	2.92	118.88	113.91
3	B	269	PEP	O2-C2-C3	-2.91	119.19	124.79
3	H	269	PEP	O2'-C1-O1	-2.89	116.99	123.61
3	H	268	PEP	O3P-P-O2P	2.88	118.64	107.64
3	C	268	PEP	O2'-C1-C2	2.83	118.74	113.91
3	H	268	PEP	O2'-C1-C2	2.78	118.64	113.91
3	L	268	PEP	O2'-C1-O1	-2.60	117.65	123.61
3	K	268	PEP	O2'-C1-C2	2.54	118.24	113.91
3	H	269	PEP	O2'-C1-C2	2.51	118.18	113.91
3	H	268	PEP	O3P-P-O2	-2.50	97.64	105.25
3	I	268	PEP	O1-C1-C2	-2.49	118.04	121.79
3	J	268	PEP	O1-C1-C2	-2.46	118.08	121.79
3	H	268	PEP	O2'-C1-O1	-2.41	118.09	123.61
3	E	268	PEP	O1-C1-C2	2.40	125.40	121.79
3	L	268	PEP	O2-P-O1P	-2.36	100.93	109.32
3	G	268	PEP	O2'-C1-O1	-2.21	118.55	123.61
3	G	269	PEP	O2-C2-C3	-2.12	120.71	124.79
3	I	268	PEP	O3P-P-O2P	2.12	115.72	107.64
3	F	268	PEP	O2-C2-C3	-2.10	120.74	124.79
3	C	269	PEP	O2'-C1-O1	-2.05	118.92	123.61

Continued on next page...

Continued from previous page...

Mol	Chain	Res	Type	Atoms	Z	Observed(°)	Ideal(°)
3	E	268	PEP	O3P-P-O2P	2.05	115.46	107.64
3	G	268	PEP	O3P-P-O1P	2.02	118.59	110.68

There are no chirality outliers.

All (53) torsion outliers are listed below:

Mol	Chain	Res	Type	Atoms
3	B	268	PEP	O1-C1-C2-C3
3	B	268	PEP	O2'-C1-C2-C3
3	B	268	PEP	O2'-C1-C2-O2
3	C	268	PEP	O1-C1-C2-C3
3	C	268	PEP	O2'-C1-C2-C3
3	C	269	PEP	O1-C1-C2-C3
3	C	269	PEP	O2'-C1-C2-C3
3	C	269	PEP	C1-C2-O2-P
3	C	269	PEP	C3-C2-O2-P
3	D	268	PEP	O1-C1-C2-C3
3	D	268	PEP	O2'-C1-C2-C3
3	F	268	PEP	O2'-C1-C2-O2
3	G	269	PEP	O1-C1-C2-C3
3	G	269	PEP	O2'-C1-C2-C3
3	H	269	PEP	O1-C1-C2-C3
3	H	269	PEP	O1-C1-C2-O2
3	H	269	PEP	O2'-C1-C2-C3
3	H	269	PEP	O2'-C1-C2-O2
3	I	268	PEP	O2'-C1-C2-O2
3	I	269	PEP	O1-C1-C2-C3
3	I	269	PEP	O1-C1-C2-O2
3	I	269	PEP	O2'-C1-C2-C3
3	I	269	PEP	O2'-C1-C2-O2
3	J	268	PEP	O1-C1-C2-C3
3	J	268	PEP	O2'-C1-C2-C3
3	K	268	PEP	O1-C1-C2-C3
3	K	268	PEP	O1-C1-C2-O2
3	K	268	PEP	O2'-C1-C2-C3
3	L	268	PEP	O1-C1-C2-C3
3	L	268	PEP	O2'-C1-C2-C3
3	B	268	PEP	O1-C1-C2-O2
3	C	268	PEP	O1-C1-C2-O2
3	C	269	PEP	O1-C1-C2-O2
3	D	268	PEP	O1-C1-C2-O2
3	F	268	PEP	O1-C1-C2-O2

Continued on next page...

Continued from previous page...

Mol	Chain	Res	Type	Atoms
3	G	269	PEP	O1-C1-C2-O2
3	I	268	PEP	O1-C1-C2-O2
3	J	268	PEP	O1-C1-C2-O2
3	L	268	PEP	O1-C1-C2-O2
3	J	268	PEP	C2-O2-P-O2P
3	F	268	PEP	O1-C1-C2-C3
3	I	268	PEP	O1-C1-C2-C3
3	C	268	PEP	O2'-C1-C2-O2
3	C	269	PEP	O2'-C1-C2-O2
3	D	268	PEP	O2'-C1-C2-O2
3	G	269	PEP	O2'-C1-C2-O2
3	J	268	PEP	O2'-C1-C2-O2
3	K	268	PEP	O2'-C1-C2-O2
3	L	268	PEP	O2'-C1-C2-O2
3	F	268	PEP	C2-O2-P-O2P
3	I	268	PEP	O2'-C1-C2-C3
3	C	269	PEP	C2-O2-P-O3P
3	K	268	PEP	C2-O2-P-O2P

There are no ring outliers.

12 monomers are involved in 17 short contacts:

Mol	Chain	Res	Type	Clashes	Symm-Clashes
3	E	268	PEP	1	0
3	J	268	PEP	1	0
2	J	269	PO4	1	0
3	F	268	PEP	2	0
3	I	268	PEP	1	0
3	I	269	PEP	1	0
3	H	268	PEP	1	0
3	B	268	PEP	2	0
3	H	269	PEP	2	0
3	B	269	PEP	3	0
3	L	268	PEP	1	0
3	D	268	PEP	1	0

5.7 Other polymers [i](#)

There are no such residues in this entry.

5.8 Polymer linkage issues

There are no chain breaks in this entry.

6 Fit of model and data

6.1 Protein, DNA and RNA chains

In the following table, the column labelled ‘#RSRZ > 2’ contains the number (and percentage) of RSRZ outliers, followed by percent RSRZ outliers for the chain as percentile scores relative to all X-ray entries and entries of similar resolution. The OWAB column contains the minimum, median, 95th percentile and maximum values of the occupancy-weighted average B-factor per residue. The column labelled ‘Q < 0.9’ lists the number of (and percentage) of residues with an average occupancy less than 0.9.

Mol	Chain	Analysed	<RSRZ>	#RSRZ>2	OWAB(Å ²)	Q<0.9
1	A	257/263 (97%)	-0.33	4 (1%) 72 77	25, 38, 58, 80	0
1	B	258/263 (98%)	-0.18	5 (1%) 66 73	23, 38, 58, 94	0
1	C	257/263 (97%)	0.12	9 (3%) 44 51	31, 58, 82, 92	0
1	D	256/263 (97%)	0.36	16 (6%) 20 25	32, 65, 84, 92	0
1	E	256/263 (97%)	0.45	29 (11%) 5 7	35, 72, 100, 107	0
1	F	255/263 (96%)	0.62	27 (10%) 6 8	40, 75, 97, 102	0
1	G	259/263 (98%)	-0.20	6 (2%) 60 67	26, 41, 66, 109	0
1	H	256/263 (97%)	-0.24	2 (0%) 86 89	28, 40, 62, 84	0
1	I	262/263 (99%)	-0.12	10 (3%) 40 47	24, 40, 64, 97	0
1	J	262/263 (99%)	-0.18	9 (3%) 45 52	28, 42, 73, 101	0
1	K	257/263 (97%)	0.92	43 (16%) 1 2	40, 86, 108, 118	0
1	L	256/263 (97%)	0.47	23 (8%) 9 12	38, 65, 88, 97	0
All	All	3091/3156 (97%)	0.14	183 (5%) 22 28	23, 51, 93, 118	0

All (183) RSRZ outliers are listed below:

Mol	Chain	Res	Type	RSRZ
1	G	264	ILE	11.0
1	B	194	GLY	10.3
1	J	264	ILE	9.6
1	H	264	ILE	8.2
1	B	264	ILE	6.9
1	I	194	GLY	6.9
1	G	263	THR	6.7
1	K	193	LEU	6.6
1	B	193	LEU	6.4
1	D	198	GLY	6.3
1	A	264	ILE	6.1

Continued on next page...

Continued from previous page...

Mol	Chain	Res	Type	RSRZ
1	E	264	ILE	6.1
1	K	264	ILE	6.1
1	D	264	ILE	6.1
1	G	195	ASP	6.0
1	K	232	SER	5.9
1	I	193	LEU	5.8
1	F	264	ILE	5.8
1	I	198	GLY	5.7
1	F	94	VAL	5.7
1	I	264	ILE	5.5
1	I	197	SER	5.5
1	K	12	ALA	5.4
1	J	193	LEU	5.4
1	C	57	GLY	5.0
1	J	198	GLY	5.0
1	G	193	LEU	4.9
1	I	263	THR	4.9
1	K	263	THR	4.9
1	L	191	GLY	4.8
1	J	263	THR	4.7
1	J	197	SER	4.6
1	K	55	PHE	4.6
1	L	57	GLY	4.5
1	K	192	GLY	4.4
1	K	72	GLU	4.4
1	F	57	GLY	4.3
1	K	199	GLY	4.3
1	F	7	ILE	4.2
1	G	194	GLY	4.2
1	H	263	THR	4.1
1	L	231	LEU	4.1
1	K	57	GLY	4.1
1	K	95	ALA	4.0
1	K	116	LYS	4.0
1	K	231	LEU	4.0
1	L	143	PHE	3.9
1	C	264	ILE	3.9
1	A	263	THR	3.9
1	E	147	LYS	3.9
1	L	234	ALA	3.7
1	F	263	THR	3.7
1	L	264	ILE	3.6

Continued on next page...

Continued from previous page...

Mol	Chain	Res	Type	RSRZ
1	E	54	SER	3.6
1	J	194	GLY	3.6
1	E	62	TYR	3.6
1	A	193	LEU	3.6
1	L	192	GLY	3.5
1	G	192	GLY	3.5
1	L	54	SER	3.5
1	K	143	PHE	3.4
1	D	72	GLU	3.4
1	K	9	GLY	3.4
1	E	227	PRO	3.4
1	K	147	LYS	3.3
1	C	198	GLY	3.3
1	L	235	SER	3.3
1	E	229	LYS	3.3
1	B	263	THR	3.2
1	I	196	LYS	3.2
1	E	53	HIS	3.2
1	E	10	MET	3.2
1	B	192	GLY	3.2
1	F	228	GLU	3.1
1	K	8	ALA	3.1
1	E	190	PRO	3.0
1	E	17	GLU	3.0
1	F	231	LEU	2.9
1	J	195	ASP	2.9
1	F	9	GLY	2.9
1	C	235	SER	2.9
1	D	69	LYS	2.9
1	L	52	ILE	2.9
1	F	15	SER	2.9
1	K	54	SER	2.9
1	I	199	GLY	2.9
1	K	34	LYS	2.8
1	D	263	THR	2.8
1	K	40	PHE	2.8
1	F	227	PRO	2.8
1	E	7	ILE	2.8
1	E	42	SER	2.8
1	E	16	GLU	2.8
1	L	55	PHE	2.7
1	D	7	ILE	2.7

Continued on next page...

Continued from previous page...

Mol	Chain	Res	Type	RSRZ
1	F	31	GLU	2.7
1	K	227	PRO	2.7
1	F	220	PHE	2.7
1	F	199	GLY	2.7
1	E	8	ALA	2.7
1	I	192	GLY	2.7
1	D	8	ALA	2.7
1	F	89	GLU	2.7
1	F	93	GLU	2.7
1	L	18	LEU	2.7
1	J	196	LYS	2.6
1	F	6	VAL	2.6
1	F	52	ILE	2.6
1	E	9	GLY	2.6
1	D	16	GLU	2.6
1	K	22	VAL	2.6
1	K	79	THR	2.6
1	C	143	PHE	2.6
1	L	85	SER	2.6
1	D	200	MET	2.6
1	F	229	LYS	2.6
1	D	68	ARG	2.6
1	E	220	PHE	2.6
1	F	219	VAL	2.5
1	F	72	GLU	2.5
1	D	144	GLY	2.5
1	L	113	ALA	2.5
1	C	192	GLY	2.5
1	E	51	SER	2.5
1	L	20	LEU	2.5
1	L	220	PHE	2.4
1	K	20	LEU	2.4
1	I	195	ASP	2.4
1	K	31	GLU	2.4
1	K	17	GLU	2.4
1	E	61	GLU	2.4
1	F	3	LYS	2.3
1	K	38	PHE	2.3
1	J	192	GLY	2.3
1	L	53	HIS	2.3
1	E	34	LYS	2.3
1	F	118	GLY	2.3

Continued on next page...

Continued from previous page...

Mol	Chain	Res	Type	RSRZ
1	L	3	LYS	2.3
1	F	8	ALA	2.3
1	E	228	GLU	2.3
1	K	53	HIS	2.3
1	L	190	PRO	2.3
1	K	7	ILE	2.3
1	L	51	SER	2.3
1	K	23	GLY	2.2
1	K	63	GLY	2.2
1	F	119	ARG	2.2
1	D	9	GLY	2.2
1	K	42	SER	2.2
1	E	234	ALA	2.2
1	K	39	VAL	2.2
1	K	259	LYS	2.2
1	L	94	VAL	2.2
1	E	40	PHE	2.2
1	D	6	VAL	2.2
1	D	219	VAL	2.2
1	E	20	LEU	2.2
1	K	111	LEU	2.2
1	K	3	LYS	2.1
1	K	65	LYS	2.1
1	D	220	PHE	2.1
1	K	36	VAL	2.1
1	E	57	GLY	2.1
1	E	72	GLU	2.1
1	E	116	LYS	2.1
1	K	69	LYS	2.1
1	C	147	LYS	2.1
1	K	58	HIS	2.1
1	K	91	VAL	2.1
1	C	7	ILE	2.1
1	E	65	LYS	2.1
1	F	121	VAL	2.1
1	K	35	GLU	2.0
1	E	35	GLU	2.0
1	F	259	LYS	2.0
1	A	228	GLU	2.0
1	D	199	GLY	2.0
1	L	147	LYS	2.0
1	K	74	PHE	2.0

Continued on next page...

Continued from previous page...

Mol	Chain	Res	Type	RSRZ
1	L	86	TRP	2.0
1	C	61	GLU	2.0
1	E	79	THR	2.0
1	F	80	THR	2.0

6.2 Non-standard residues in protein, DNA, RNA chains [i](#)

There are no non-standard protein/DNA/RNA residues in this entry.

6.3 Carbohydrates [i](#)

There are no monosaccharides in this entry.

6.4 Ligands [i](#)

In the following table, the Atoms column lists the number of modelled atoms in the group and the number defined in the chemical component dictionary. The B-factors column lists the minimum, median, 95th percentile and maximum values of B factors of atoms in the group. The column labelled 'Q< 0.9' lists the number of atoms with occupancy less than 0.9.

Mol	Type	Chain	Res	Atoms	RSCC	RSR	B-factors(Å ²)	Q<0.9
2	PO4	K	269	5/5	0.85	0.14	122,123,123,123	0
2	PO4	L	269	5/5	0.91	0.13	103,103,104,104	0
3	PEP	G	269	10/10	0.91	0.17	67,71,76,77	0
2	PO4	F	269	5/5	0.92	0.11	90,90,90,91	0
3	PEP	H	269	10/10	0.93	0.19	62,67,73,73	0
2	PO4	E	269	5/5	0.94	0.09	97,98,98,99	0
3	PEP	C	269	10/10	0.94	0.13	88,88,89,89	0
2	PO4	A	269	5/5	0.95	0.12	53,55,55,58	0
3	PEP	F	268	10/10	0.95	0.13	72,76,77,79	0
3	PEP	I	269	10/10	0.95	0.13	55,62,70,71	0
3	PEP	C	268	10/10	0.96	0.17	53,56,59,60	0
2	PO4	D	269	5/5	0.96	0.08	80,80,80,81	0
3	PEP	B	269	10/10	0.96	0.11	52,59,65,65	0
3	PEP	K	268	10/10	0.96	0.14	76,79,81,82	0
3	PEP	L	268	10/10	0.96	0.17	69,73,74,74	0
2	PO4	J	269	5/5	0.97	0.10	61,63,64,64	0
3	PEP	D	268	10/10	0.97	0.10	50,55,60,60	0
3	PEP	E	268	10/10	0.97	0.20	66,68,71,71	0
3	PEP	G	268	10/10	0.98	0.14	33,39,44,46	0

Continued on next page...

Continued from previous page...

Mol	Type	Chain	Res	Atoms	RSCC	RSR	B-factors(\AA^2)	Q<0.9
3	PEP	I	268	10/10	0.99	0.17	30,35,38,39	0
3	PEP	B	268	10/10	0.99	0.18	31,34,36,42	0
3	PEP	J	268	10/10	0.99	0.13	32,38,44,45	0
3	PEP	H	268	10/10	0.99	0.14	28,34,38,38	0
3	PEP	A	268	10/10	0.99	0.13	32,35,38,39	0

6.5 Other polymers [i](#)

There are no such residues in this entry.