



wwPDB X-ray Structure Validation Summary Report ⓘ

Aug 26, 2024 – 04:13 PM JST

PDB ID : 8W7E
Title : Design, synthesis and biological evaluations of novel small molecular hyper-activators of human caseinolytic peptidase P (hClpP)
Authors : Jiang, J.-X.; Ding, H.; Chen, M.-R.; Lu, M.-L.; Sun, H.-Y.; Xiao, Y.-B.
Deposited on : 2023-08-30
Resolution : 2.80 Å(reported)

This is a wwPDB X-ray Structure Validation Summary Report for a publicly released PDB entry.

We welcome your comments at validation@mail.wwpdb.org

A user guide is available at

<https://www.wwpdb.org/validation/2017/XrayValidationReportHelp>

with specific help available everywhere you see the ⓘ symbol.

The types of validation reports are described at

<http://www.wwpdb.org/validation/2017/FAQs#types>.

The following versions of software and data (see [references ⓘ](#)) were used in the production of this report:

MolProbity : 4.02b-467
Mogul : 1.8.5 (274361), CSD as541be (2020)
Xtrriage (Phenix) : 1.13
EDS : 3.0
buster-report : 1.1.7 (2018)
Percentile statistics : 20231227.v01 (using entries in the PDB archive December 27th 2023)
CCP4 : 9.0.002 (Gargrove)
Density-Fitness : 1.0.11
Ideal geometry (proteins) : Engh & Huber (2001)
Ideal geometry (DNA, RNA) : Parkinson et al. (1996)
Validation Pipeline (wwPDB-VP) : 2.38.2

1 Overall quality at a glance

The following experimental techniques were used to determine the structure:

X-RAY DIFFRACTION

The reported resolution of this entry is 2.80 Å.

Percentile scores (ranging between 0-100) for global validation metrics of the entry are shown in the following graphic. The table shows the number of entries on which the scores are based.

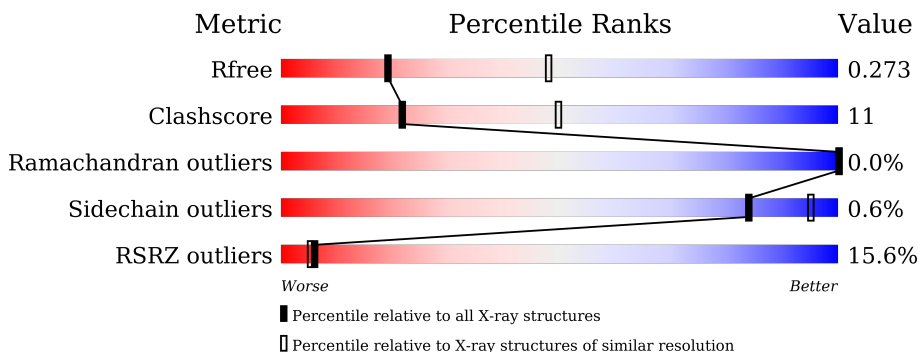





Metric	Whole archive (#Entries)	Similar resolution (#Entries, resolution range(Å))
R_{free}	164625	3657 (2.80-2.80)
Clashscore	180529	4123 (2.80-2.80)
Ramachandran outliers	177936	4071 (2.80-2.80)
Sidechain outliers	177891	4073 (2.80-2.80)
RSRZ outliers	164620	3659 (2.80-2.80)

The table below summarises the geometric issues observed across the polymeric chains and their fit to the electron density. The red, orange, yellow and green segments of the lower bar indicate the fraction of residues that contain outliers for ≥ 3 , 2, 1 and 0 types of geometric quality criteria respectively. A grey segment represents the fraction of residues that are not modelled. The numeric value for each fraction is indicated below the corresponding segment, with a dot representing fractions $\leq 5\%$. The upper red bar (where present) indicates the fraction of residues that have poor fit to the electron density. The numeric value is given above the bar.

Mol	Chain	Length	Quality of chain
1	A	223	 4% 61% 18% 22%
1	B	223	 5% 64% 15% 21%
1	C	223	 7% 65% 14% 22%
1	D	223	 9% 65% 14% 21%
1	E	223	 8% 62% 16% 22%
1	F	223	 11% 51% 28% 21%

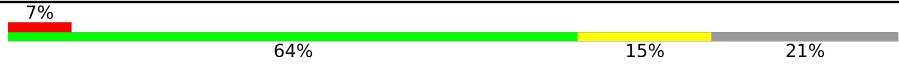
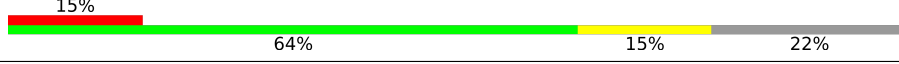
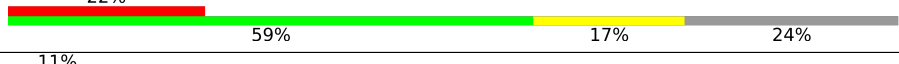
Continued on next page...

Continued from previous page...

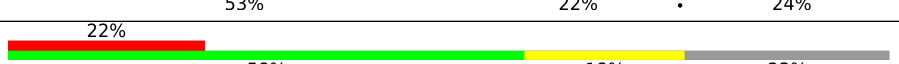
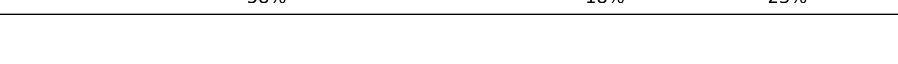
Mol	Chain	Length	Quality of chain
1	G	223	 <p>7% 64% 15% 21%</p>
1	H	223	 <p>15% 64% 15% 22%</p>
1	I	223	 <p>22% 59% 17% 24%</p>
1	J	223	 <p>11% 58% 17% 25%</p>
1	K	223	 <p>13% 57% 20% 23%</p>
1	L	223	 <p>10% 55% 21% 23%</p>
1	M	223	 <p>26% 53% 22% 24%</p>
1	N	223	 <p>22% 58% 18% 23%</p>

2 Entry composition [i](#)

There are 2 unique types of molecules in this entry. The entry contains 19090 atoms, of which 0 are hydrogens and 0 are deuteriums.

In the tables below, the ZeroOcc column contains the number of atoms modelled with zero occupancy, the AltConf column contains the number of residues with at least one atom in alternate conformation and the Trace column contains the number of residues modelled with at most 2 atoms.

- Molecule 1 is a protein called ATP-dependent Clp protease proteolytic subunit, mitochondrial.

Mol	Chain	Residues	Atoms					ZeroOcc	AltConf	Trace
			Total	C	N	O	S			
1	A	175	Total 1359	C 868	N 231	O 247	S 13	0	1	0
1	B	176	Total 1352	C 863	N 229	O 247	S 13	0	0	0
1	C	175	Total 1365	C 870	N 231	O 250	S 14	0	2	0
1	D	176	Total 1370	C 873	N 233	O 251	S 13	0	1	0
1	E	174	Total 1339	C 856	N 226	O 243	S 14	0	1	0
1	F	177	Total 1374	C 876	N 234	O 252	S 12	0	1	0
1	G	176	Total 1347	C 863	N 227	O 244	S 13	0	0	0
1	H	175	Total 1336	C 853	N 226	O 244	S 13	0	0	0
1	I	169	Total 1296	C 828	N 219	O 236	S 13	0	0	0
1	J	168	Total 1276	C 818	N 216	O 229	S 13	0	0	0
1	K	172	Total 1314	C 841	N 222	O 238	S 13	0	0	0
1	L	172	Total 1330	C 852	N 223	O 242	S 13	0	0	0
1	M	170	Total 1283	C 823	N 212	O 236	S 12	0	1	0
1	N	171	Total 1315	C 844	N 219	O 239	S 13	0	0	0

There are 42 discrepancies between the modelled and reference sequences:

Chain	Residue	Modelled	Actual	Comment	Reference
A	55	GLY	-	linker	UNP Q16740
A	56	SER	-	linker	UNP Q16740
A	57	SER	-	linker	UNP Q16740
B	55	GLY	-	linker	UNP Q16740
B	56	SER	-	linker	UNP Q16740
B	57	SER	-	linker	UNP Q16740
C	55	GLY	-	linker	UNP Q16740
C	56	SER	-	linker	UNP Q16740
C	57	SER	-	linker	UNP Q16740
D	55	GLY	-	linker	UNP Q16740
D	56	SER	-	linker	UNP Q16740
D	57	SER	-	linker	UNP Q16740
E	55	GLY	-	linker	UNP Q16740
E	56	SER	-	linker	UNP Q16740
E	57	SER	-	linker	UNP Q16740
F	55	GLY	-	linker	UNP Q16740
F	56	SER	-	linker	UNP Q16740
F	57	SER	-	linker	UNP Q16740
G	55	GLY	-	linker	UNP Q16740
G	56	SER	-	linker	UNP Q16740
G	57	SER	-	linker	UNP Q16740
H	55	GLY	-	linker	UNP Q16740
H	56	SER	-	linker	UNP Q16740
H	57	SER	-	linker	UNP Q16740
I	55	GLY	-	linker	UNP Q16740
I	56	SER	-	linker	UNP Q16740
I	57	SER	-	linker	UNP Q16740
J	55	GLY	-	linker	UNP Q16740
J	56	SER	-	linker	UNP Q16740
J	57	SER	-	linker	UNP Q16740
K	55	GLY	-	linker	UNP Q16740
K	56	SER	-	linker	UNP Q16740
K	57	SER	-	linker	UNP Q16740
L	55	GLY	-	linker	UNP Q16740
L	56	SER	-	linker	UNP Q16740
L	57	SER	-	linker	UNP Q16740
M	55	GLY	-	linker	UNP Q16740
M	56	SER	-	linker	UNP Q16740
M	57	SER	-	linker	UNP Q16740
N	55	GLY	-	linker	UNP Q16740
N	56	SER	-	linker	UNP Q16740
N	57	SER	-	linker	UNP Q16740

- Molecule 2 is 3-[(3-chlorophenyl)methyl]-6-[(4-chlorophenyl)methyl]-2,4-dihydro-1H-pyrido[

2,3-c[[2,7]naphthyridin-5-one (three-letter code: 9I3) (formula: C₂₅H₂₁Cl₂N₃O).

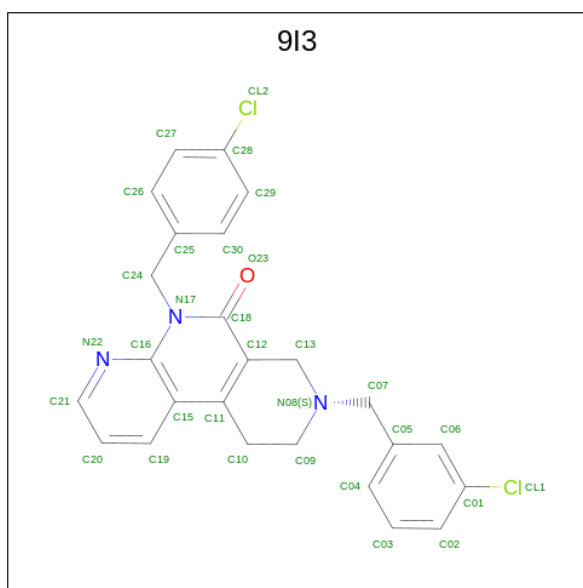

Mol	Chain	Residues	Atoms				ZeroOcc	AltConf	
2	A	1	Total	C	Cl	N	O	0	0
			31	25	2	3	1		
2	B	1	Total	C	Cl	N	O	0	0
			31	25	2	3	1		
2	C	1	Total	C	Cl	N	O	0	0
			31	25	2	3	1		
2	D	1	Total	C	Cl	N	O	0	0
			31	25	2	3	1		
2	E	1	Total	C	Cl	N	O	0	0
			31	25	2	3	1		
2	E	1	Total	C	Cl	N	O	0	0
			31	25	2	3	1		
2	F	1	Total	C	Cl	N	O	0	0
			31	25	2	3	1		
2	G	1	Total	C	Cl	N	O	0	0
			31	25	2	3	1		
2	H	1	Total	C	Cl	N	O	0	0
			31	25	2	3	1		
2	I	1	Total	C	Cl	N	O	0	0
			31	25	2	3	1		
2	K	1	Total	C	Cl	N	O	0	0
			31	25	2	3	1		
2	L	1	Total	C	Cl	N	O	0	0
			31	25	2	3	1		
2	M	1	Total	C	Cl	N	O	0	0
			31	25	2	3	1		

Continued on next page...

Continued from previous page...

Mol	Chain	Residues	Atoms				ZeroOcc	AltConf	
			Total	C	Cl	N			O
2	N	1	31	25	2	3	1	0	0

3 Residue-property plots i

These plots are drawn for all protein, RNA, DNA and oligosaccharide chains in the entry. The first graphic for a chain summarises the proportions of the various outlier classes displayed in the second graphic. The second graphic shows the sequence view annotated by issues in geometry and electron density. Residues are color-coded according to the number of geometric quality criteria for which they contain at least one outlier: green = 0, yellow = 1, orange = 2 and red = 3 or more. A red dot above a residue indicates a poor fit to the electron density ($RSRZ > 2$). Stretches of 2 or more consecutive residues without any outlier are shown as a green connector. Residues present in the sample, but not in the model, are shown in grey.

- Molecule 1: ATP-dependent Clp protease proteolytic subunit, mitochondrial

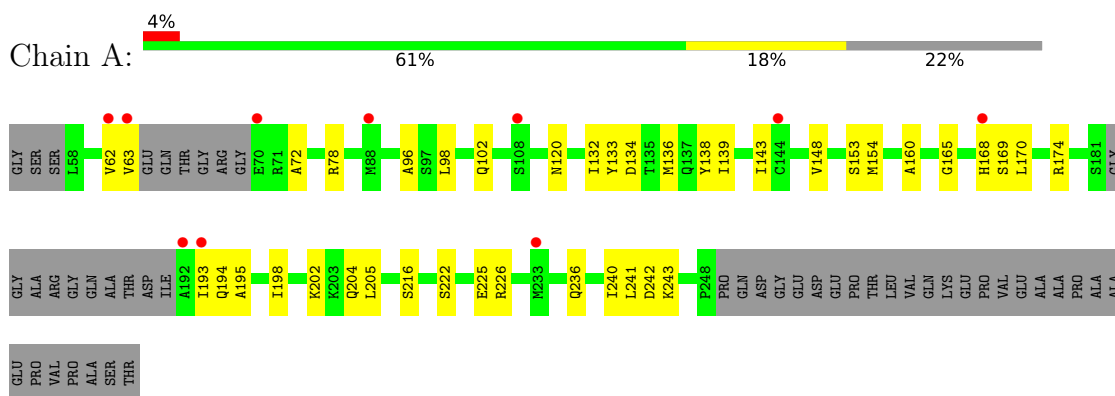

- Molecule 1: ATP-dependent Clp protease proteolytic subunit, mitochondrial

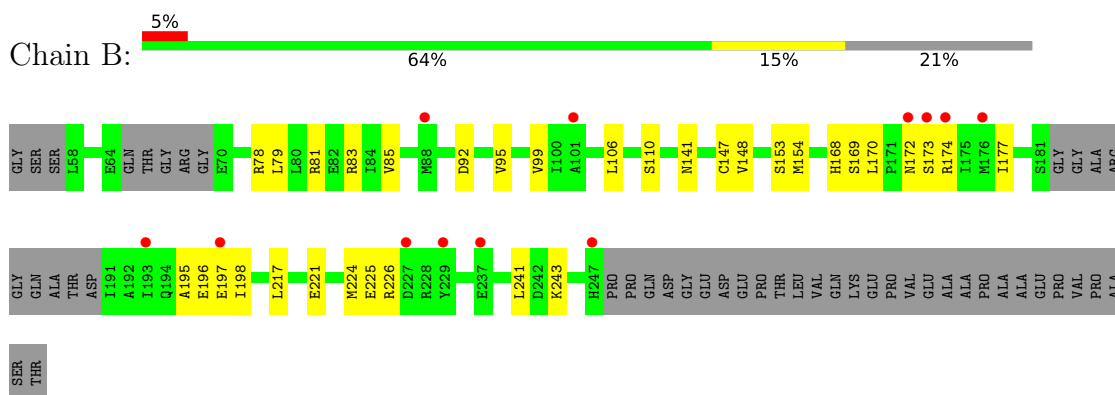

- Molecule 1: ATP-dependent Clp protease proteolytic subunit, mitochondrial

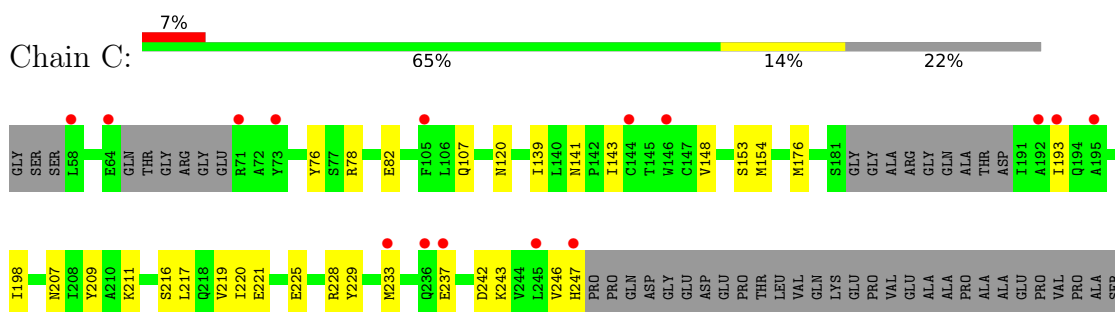

THR

- Molecule 1: ATP-dependent Clp protease proteolytic subunit, mitochondrial

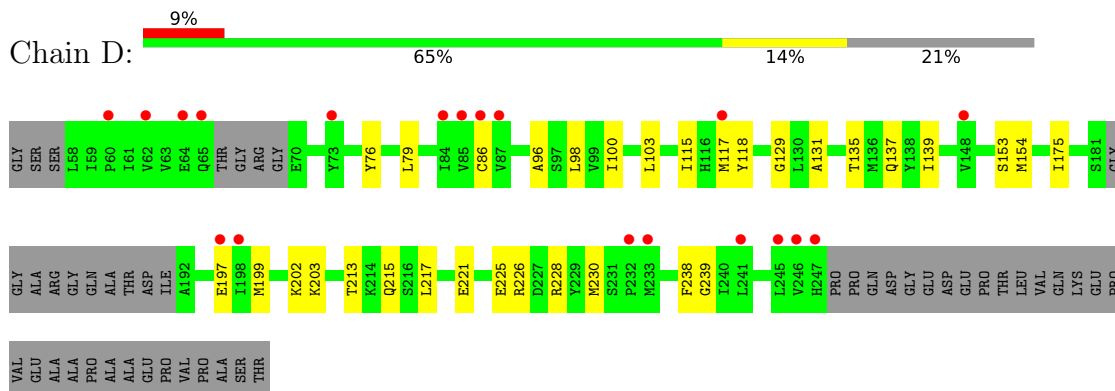

- Molecule 1: ATP-dependent Clp protease proteolytic subunit, mitochondrial

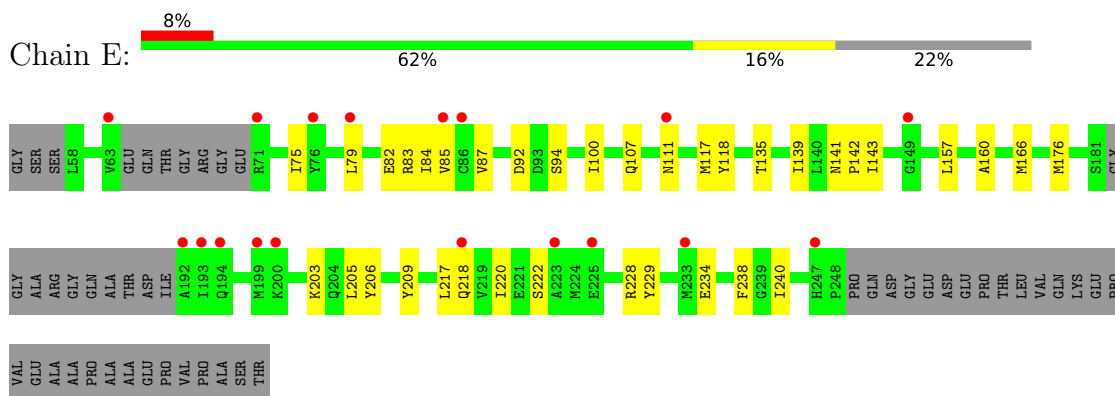

- Molecule 1: ATP-dependent Clp protease proteolytic subunit, mitochondrial

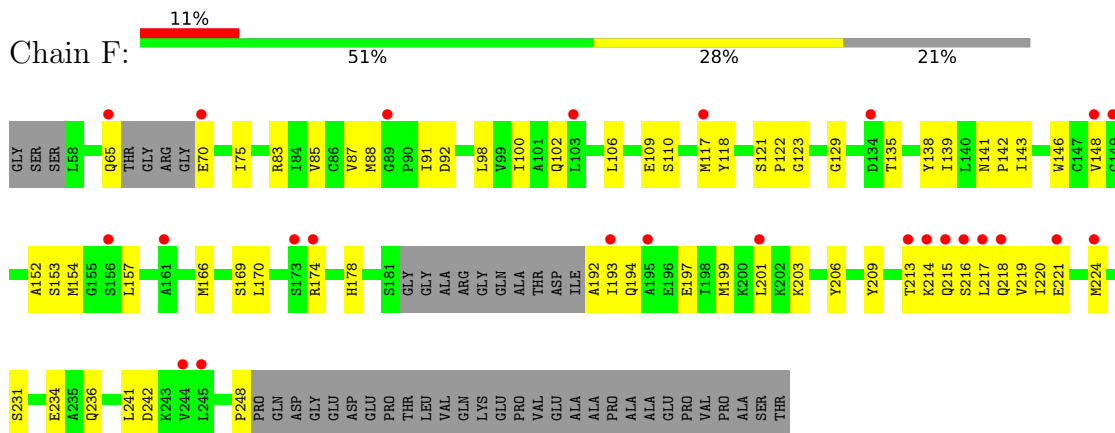

- Molecule 1: ATP-dependent Clp protease proteolytic subunit, mitochondrial

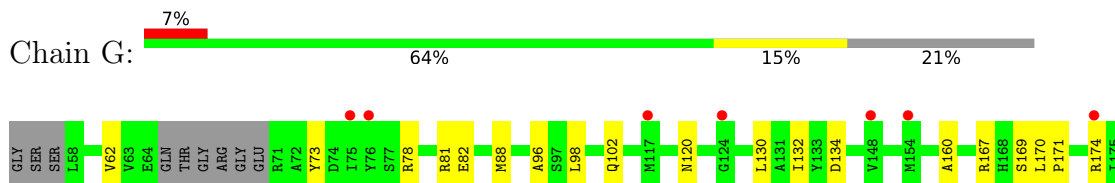

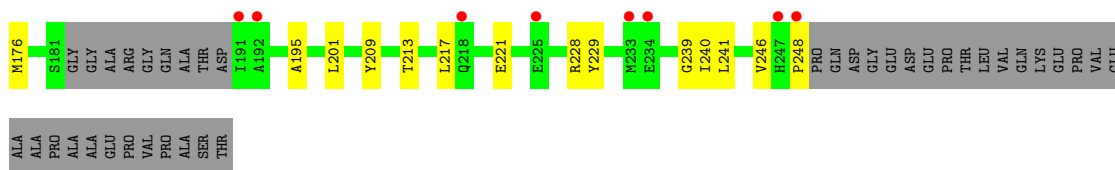

- Molecule 1: ATP-dependent Clp protease proteolytic subunit, mitochondrial

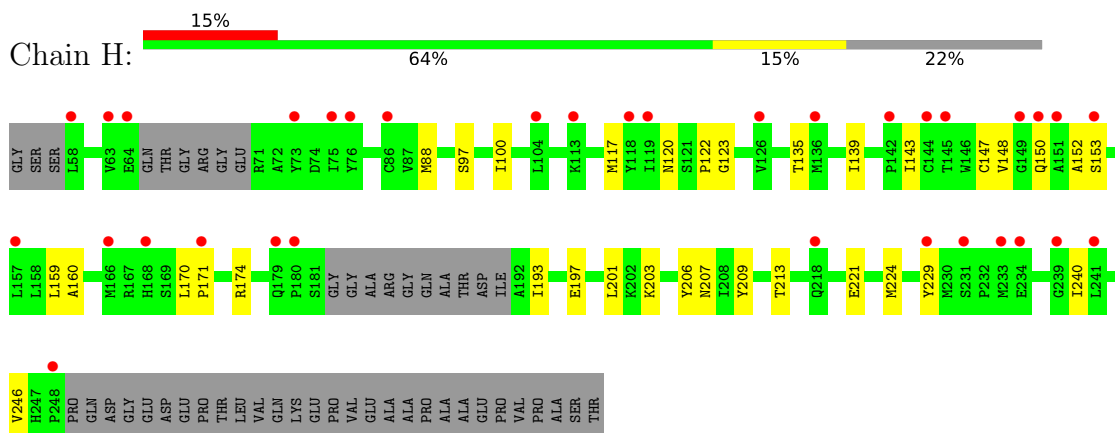

- Molecule 1: ATP-dependent Clp protease proteolytic subunit, mitochondrial

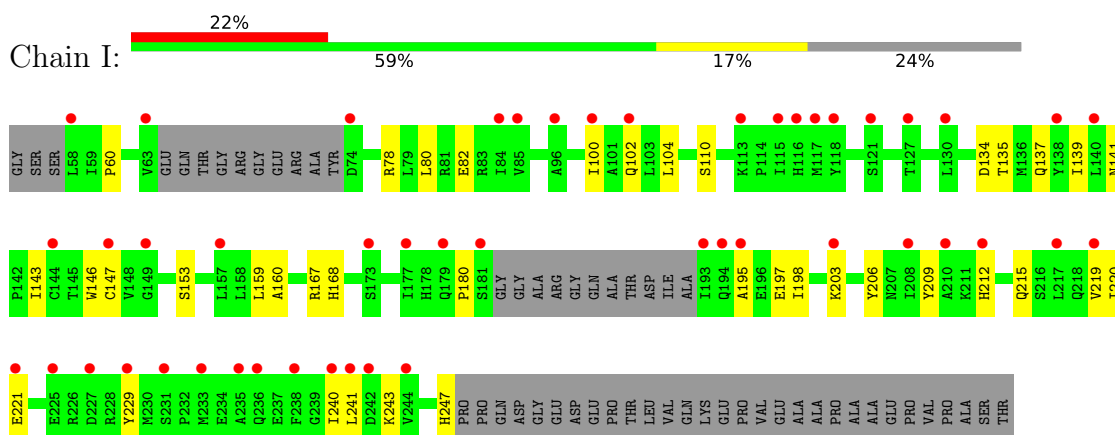

- Molecule 1: ATP-dependent Clp protease proteolytic subunit, mitochondrial

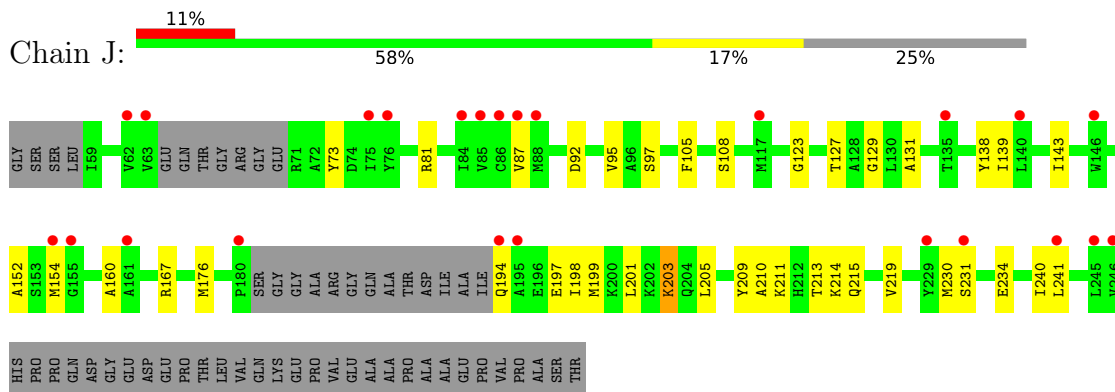

- Molecule 1: ATP-dependent Clp protease proteolytic subunit, mitochondrial

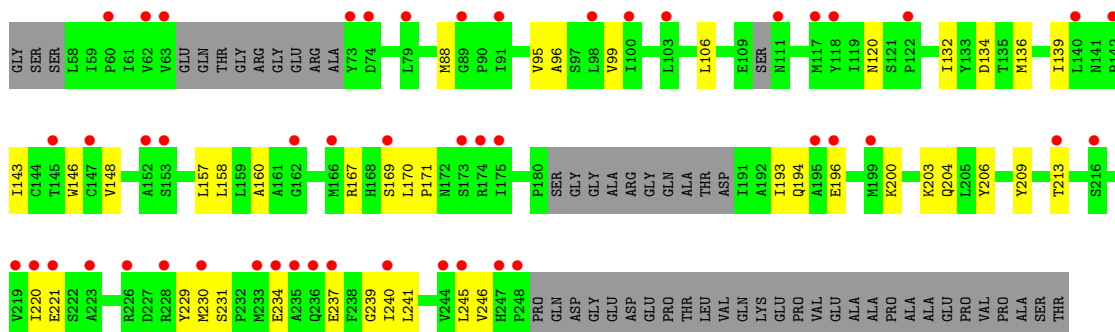

4 Data and refinement statistics

Property	Value	Source
Space group	C 1 2 1	Depositor
Cell constants a, b, c, α , β , γ	164.77Å 119.22Å 152.81Å 90.00° 100.82° 90.00°	Depositor
Resolution (Å)	46.65 – 2.80 46.65 – 2.80	Depositor EDS
% Data completeness (in resolution range)	99.6 (46.65-2.80) 88.0 (46.65-2.80)	Depositor EDS
R_{merge}	(Not available)	Depositor
R_{sym}	(Not available)	Depositor
$\langle I/\sigma(I) \rangle$ ¹	0.20 (at 2.77Å)	Xtrriage
Refinement program	PHENIX (1.18.2_3874: ???)	Depositor
R, R_{free}	0.266 , 0.274 0.265 , 0.273	Depositor DCC
R_{free} test set	69618 reflections (2.76%)	wwPDB-VP
Wilson B-factor (Å ²)	49.8	Xtrriage
Anisotropy	0.344	Xtrriage
Bulk solvent k_{sol} (e/Å ³), B_{sol} (Å ²)	0.29 , 25.4	EDS
L-test for twinning ²	$\langle L \rangle = 0.47$, $\langle L^2 \rangle = 0.30$	Xtrriage
Estimated twinning fraction	No twinning to report.	Xtrriage
F_o, F_c correlation	0.88	EDS
Total number of atoms	19090	wwPDB-VP
Average B, all atoms (Å ²)	63.0	wwPDB-VP

Xtrriage's analysis on translational NCS is as follows: *The largest off-origin peak in the Patterson function is 2.90% of the height of the origin peak. No significant pseudotranslation is detected.*

¹Intensities estimated from amplitudes.

²Theoretical values of $\langle |L| \rangle$, $\langle L^2 \rangle$ for acentric reflections are 0.5, 0.333 respectively for untwinned datasets, and 0.375, 0.2 for perfectly twinned datasets.

5 Model quality [i](#)

5.1 Standard geometry [i](#)

Bond lengths and bond angles in the following residue types are not validated in this section: 9I3

The Z score for a bond length (or angle) is the number of standard deviations the observed value is removed from the expected value. A bond length (or angle) with $|Z| > 5$ is considered an outlier worth inspection. RMSZ is the root-mean-square of all Z scores of the bond lengths (or angles).

Mol	Chain	Bond lengths		Bond angles	
		RMSZ	# Z >5	RMSZ	# Z >5
1	A	0.35	0/1383	0.52	0/1871
1	B	0.27	0/1375	0.44	0/1861
1	C	0.26	0/1388	0.48	0/1877
1	D	0.29	0/1393	0.52	0/1883
1	E	0.32	0/1362	0.54	0/1843
1	F	0.37	0/1398	0.55	0/1892
1	G	0.28	0/1371	0.48	0/1858
1	H	0.25	0/1359	0.49	0/1841
1	I	0.26	0/1318	0.53	0/1785
1	J	0.41	0/1298	0.54	0/1760
1	K	0.41	0/1336	0.56	0/1808
1	L	0.34	0/1355	0.53	0/1836
1	M	0.36	0/1306	0.55	0/1775
1	N	0.31	0/1338	0.55	0/1812
All	All	0.32	0/18980	0.52	0/25702

There are no bond length outliers.

There are no bond angle outliers.

There are no chirality outliers.

There are no planarity outliers.

5.2 Too-close contacts [i](#)

In the following table, the Non-H and H(model) columns list the number of non-hydrogen atoms and hydrogen atoms in the chain respectively. The H(added) column lists the number of hydrogen atoms added and optimized by MolProbity. The Clashes column lists the number of clashes within the asymmetric unit, whereas Symm-Clashes lists symmetry-related clashes.

Mol	Chain	Non-H	H(model)	H(added)	Clashes	Symm-Clashes
1	A	1359	0	1389	27	0
1	B	1352	0	1369	25	0
1	C	1365	0	1385	23	0
1	D	1370	0	1396	29	0
1	E	1339	0	1367	27	0
1	F	1374	0	1396	59	0
1	G	1347	0	1370	28	0
1	H	1336	0	1356	21	0
1	I	1296	0	1318	24	0
1	J	1276	0	1292	32	0
1	K	1314	0	1338	43	0
1	L	1330	0	1356	42	0
1	M	1283	0	1285	41	0
1	N	1315	0	1334	32	0
2	A	31	0	0	0	0
2	B	31	0	0	1	0
2	C	31	0	0	0	0
2	D	31	0	0	1	0
2	E	62	0	0	1	0
2	F	31	0	0	0	0
2	G	31	0	0	1	0
2	H	31	0	0	1	0
2	I	31	0	0	0	0
2	K	31	0	0	1	0
2	L	31	0	0	3	0
2	M	31	0	0	0	0
2	N	31	0	0	1	0
All	All	19090	0	18951	402	0

The all-atom clashscore is defined as the number of clashes found per 1000 atoms (including hydrogen atoms). The all-atom clashscore for this structure is 11.

The worst 5 of 402 close contacts within the same asymmetric unit are listed below, sorted by their clash magnitude.

Atom-1	Atom-2	Interatomic distance (Å)	Clash overlap (Å)
1:G:174:ARG:CZ	1:K:201:LEU:HD21	1.79	1.11
1:F:193:ILE:CG2	1:F:197:GLU:HB3	1.94	0.95
1:N:88:MET:HG2	1:N:120:ASN:HB3	1.48	0.94
1:K:129:GLY:HA3	1:K:154:MET:HE2	1.47	0.94
1:J:213:THR:HG23	1:J:215:GLN:H	1.31	0.93

There are no symmetry-related clashes.

5.3 Torsion angles [i](#)

5.3.1 Protein backbone [i](#)

In the following table, the Percentiles column shows the percent Ramachandran outliers of the chain as a percentile score with respect to all X-ray entries followed by that with respect to entries of similar resolution.

The Analysed column shows the number of residues for which the backbone conformation was analysed, and the total number of residues.

Mol	Chain	Analysed	Favoured	Allowed	Outliers	Percentiles	
1	A	170/223 (76%)	164 (96%)	6 (4%)	0	100	100
1	B	170/223 (76%)	162 (95%)	8 (5%)	0	100	100
1	C	171/223 (77%)	164 (96%)	7 (4%)	0	100	100
1	D	171/223 (77%)	164 (96%)	7 (4%)	0	100	100
1	E	169/223 (76%)	164 (97%)	5 (3%)	0	100	100
1	F	172/223 (77%)	166 (96%)	6 (4%)	0	100	100
1	G	170/223 (76%)	164 (96%)	6 (4%)	0	100	100
1	H	169/223 (76%)	161 (95%)	8 (5%)	0	100	100
1	I	163/223 (73%)	155 (95%)	8 (5%)	0	100	100
1	J	162/223 (73%)	155 (96%)	7 (4%)	0	100	100
1	K	166/223 (74%)	160 (96%)	5 (3%)	1 (1%)	22	51
1	L	166/223 (74%)	161 (97%)	5 (3%)	0	100	100
1	M	165/223 (74%)	154 (93%)	11 (7%)	0	100	100
1	N	163/223 (73%)	152 (93%)	11 (7%)	0	100	100
All	All	2347/3122 (75%)	2246 (96%)	100 (4%)	1 (0%)	100	100

All (1) Ramachandran outliers are listed below:

Mol	Chain	Res	Type
1	K	150	GLN

5.3.2 Protein sidechains [i](#)

In the following table, the Percentiles column shows the percent sidechain outliers of the chain as a percentile score with respect to all X-ray entries followed by that with respect to entries of similar resolution.

The Analysed column shows the number of residues for which the sidechain conformation was

analysed, and the total number of residues.

Mol	Chain	Analysed	Rotameric	Outliers	Percentiles	
1	A	150/186 (81%)	148 (99%)	2 (1%)	65	88
1	B	147/186 (79%)	147 (100%)	0	100	100
1	C	150/186 (81%)	150 (100%)	0	100	100
1	D	151/186 (81%)	151 (100%)	0	100	100
1	E	147/186 (79%)	146 (99%)	1 (1%)	81	94
1	F	151/186 (81%)	151 (100%)	0	100	100
1	G	147/186 (79%)	147 (100%)	0	100	100
1	H	146/186 (78%)	146 (100%)	0	100	100
1	I	143/186 (77%)	143 (100%)	0	100	100
1	J	137/186 (74%)	135 (98%)	2 (2%)	60	86
1	K	143/186 (77%)	141 (99%)	2 (1%)	62	87
1	L	148/186 (80%)	146 (99%)	2 (1%)	62	87
1	M	139/186 (75%)	136 (98%)	3 (2%)	47	79
1	N	144/186 (77%)	144 (100%)	0	100	100
All	All	2043/2604 (78%)	2031 (99%)	12 (1%)	84	95

5 of 12 residues with a non-rotameric sidechain are listed below:

Mol	Chain	Res	Type
1	L	147	CYS
1	L	150	GLN
1	M	245	LEU
1	M	220	ILE
1	J	203	LYS

Sometimes sidechains can be flipped to improve hydrogen bonding and reduce clashes. 5 of 7 such sidechains are listed below:

Mol	Chain	Res	Type
1	J	236	GLN
1	L	141	ASN
1	L	194	GLN
1	L	150	GLN
1	I	107	GLN

5.3.3 RNA [i](#)

There are no RNA molecules in this entry.

5.4 Non-standard residues in protein, DNA, RNA chains [i](#)

There are no non-standard protein/DNA/RNA residues in this entry.

5.5 Carbohydrates [i](#)

There are no oligosaccharides in this entry.

5.6 Ligand geometry [i](#)

14 ligands are modelled in this entry.

In the following table, the Counts columns list the number of bonds (or angles) for which Mogul statistics could be retrieved, the number of bonds (or angles) that are observed in the model and the number of bonds (or angles) that are defined in the Chemical Component Dictionary. The Link column lists molecule types, if any, to which the group is linked. The Z score for a bond length (or angle) is the number of standard deviations the observed value is removed from the expected value. A bond length (or angle) with $|Z| > 2$ is considered an outlier worth inspection. RMSZ is the root-mean-square of all Z scores of the bond lengths (or angles).

Mol	Type	Chain	Res	Link	Bond lengths			Bond angles		
					Counts	RMSZ	# Z > 2	Counts	RMSZ	# Z > 2
2	9I3	B	301	-	35,35,35	3.24	9 (25%)	42,50,50	1.32	8 (19%)
2	9I3	N	301	-	35,35,35	3.27	10 (28%)	42,50,50	1.34	9 (21%)
2	9I3	I	301	-	35,35,35	3.24	8 (22%)	42,50,50	1.33	9 (21%)
2	9I3	C	301	-	35,35,35	3.25	9 (25%)	42,50,50	1.30	9 (21%)
2	9I3	E	301	-	35,35,35	3.29	8 (22%)	42,50,50	1.31	7 (16%)
2	9I3	G	301	-	35,35,35	3.27	9 (25%)	42,50,50	1.32	8 (19%)
2	9I3	A	301	-	35,35,35	3.28	9 (25%)	42,50,50	1.29	8 (19%)
2	9I3	L	301	-	35,35,35	3.21	8 (22%)	42,50,50	1.52	10 (23%)
2	9I3	M	301	-	35,35,35	3.29	8 (22%)	42,50,50	1.28	7 (16%)
2	9I3	D	301	-	35,35,35	3.24	8 (22%)	42,50,50	1.37	9 (21%)
2	9I3	K	301	-	35,35,35	3.23	7 (20%)	42,50,50	1.32	8 (19%)
2	9I3	H	301	-	35,35,35	3.24	9 (25%)	42,50,50	1.42	9 (21%)
2	9I3	F	301	-	35,35,35	3.27	9 (25%)	42,50,50	1.31	7 (16%)
2	9I3	E	302	-	35,35,35	3.29	9 (25%)	42,50,50	1.28	7 (16%)

In the following table, the Chirals column lists the number of chiral outliers, the number of chiral centers analysed, the number of these observed in the model and the number defined in the Chemical Component Dictionary. Similar counts are reported in the Torsion and Rings columns. '-' means no outliers of that kind were identified.

Mol	Type	Chain	Res	Link	Chirals	Torsions	Rings
2	9I3	B	301	-	-	0/8/17/17	0/5/5/5
2	9I3	N	301	-	-	2/8/17/17	0/5/5/5
2	9I3	I	301	-	-	0/8/17/17	0/5/5/5
2	9I3	C	301	-	-	0/8/17/17	0/5/5/5
2	9I3	E	301	-	-	0/8/17/17	0/5/5/5
2	9I3	G	301	-	-	1/8/17/17	0/5/5/5
2	9I3	A	301	-	-	0/8/17/17	0/5/5/5
2	9I3	L	301	-	-	0/8/17/17	0/5/5/5
2	9I3	M	301	-	-	2/8/17/17	0/5/5/5
2	9I3	D	301	-	-	0/8/17/17	0/5/5/5
2	9I3	K	301	-	-	0/8/17/17	0/5/5/5
2	9I3	H	301	-	-	2/8/17/17	0/5/5/5
2	9I3	F	301	-	-	0/8/17/17	0/5/5/5
2	9I3	E	302	-	-	0/8/17/17	0/5/5/5

The worst 5 of 120 bond length outliers are listed below:

Mol	Chain	Res	Type	Atoms	Z	Observed(Å)	Ideal(Å)
2	M	301	9I3	C13-N08	-13.86	1.34	1.46
2	E	301	9I3	C13-N08	-13.84	1.34	1.46
2	E	302	9I3	C13-N08	-13.81	1.34	1.46
2	G	301	9I3	C13-N08	-13.67	1.34	1.46
2	N	301	9I3	C13-N08	-13.65	1.34	1.46

The worst 5 of 115 bond angle outliers are listed below:

Mol	Chain	Res	Type	Atoms	Z	Observed(°)	Ideal(°)
2	M	301	9I3	C24-N17-C18	3.55	120.42	116.91
2	D	301	9I3	C24-N17-C18	3.49	120.36	116.91
2	A	301	9I3	C24-N17-C18	3.41	120.28	116.91
2	K	301	9I3	C24-N17-C18	3.40	120.26	116.91
2	B	301	9I3	C24-N17-C18	3.39	120.25	116.91

There are no chirality outliers.

5 of 7 torsion outliers are listed below:

Mol	Chain	Res	Type	Atoms
2	M	301	9I3	C05-C07-N08-C09
2	M	301	9I3	C05-C07-N08-C13
2	N	301	9I3	C05-C07-N08-C13
2	H	301	9I3	C05-C07-N08-C13
2	N	301	9I3	C05-C07-N08-C09

There are no ring outliers.

8 monomers are involved in 10 short contacts:

Mol	Chain	Res	Type	Clashes	Symm-Clashes
2	B	301	9I3	1	0
2	N	301	9I3	1	0
2	E	301	9I3	1	0
2	G	301	9I3	1	0
2	L	301	9I3	3	0
2	D	301	9I3	1	0
2	K	301	9I3	1	0
2	H	301	9I3	1	0

The following is a two-dimensional graphical depiction of Mogul quality analysis of bond lengths, bond angles, torsion angles, and ring geometry for all instances of the Ligand of Interest. In addition, ligands with molecular weight > 250 and outliers as shown on the validation Tables will also be included. For torsion angles, if less than 5% of the Mogul distribution of torsion angles is within 10 degrees of the torsion angle in question, then that torsion angle is considered an outlier. Any bond that is central to one or more torsion angles identified as an outlier by Mogul will be highlighted in the graph. For rings, the root-mean-square deviation (RMSD) between the ring in question and similar rings identified by Mogul is calculated over all ring torsion angles. If the average RMSD is greater than 60 degrees and the minimal RMSD between the ring in question and any Mogul-identified rings is also greater than 60 degrees, then that ring is considered an outlier. The outliers are highlighted in purple. The color gray indicates Mogul did not find sufficient equivalents in the CSD to analyse the geometry.

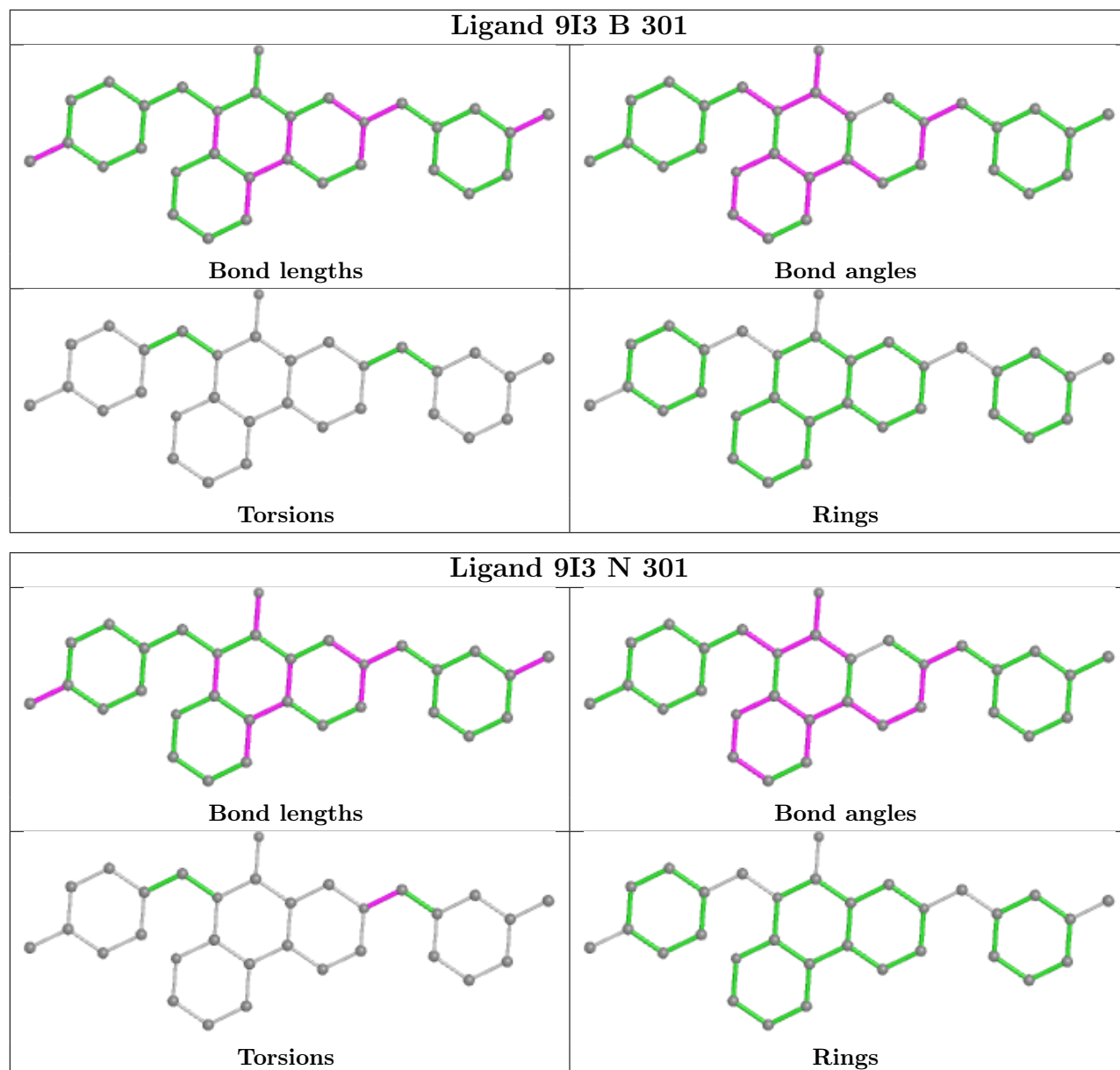

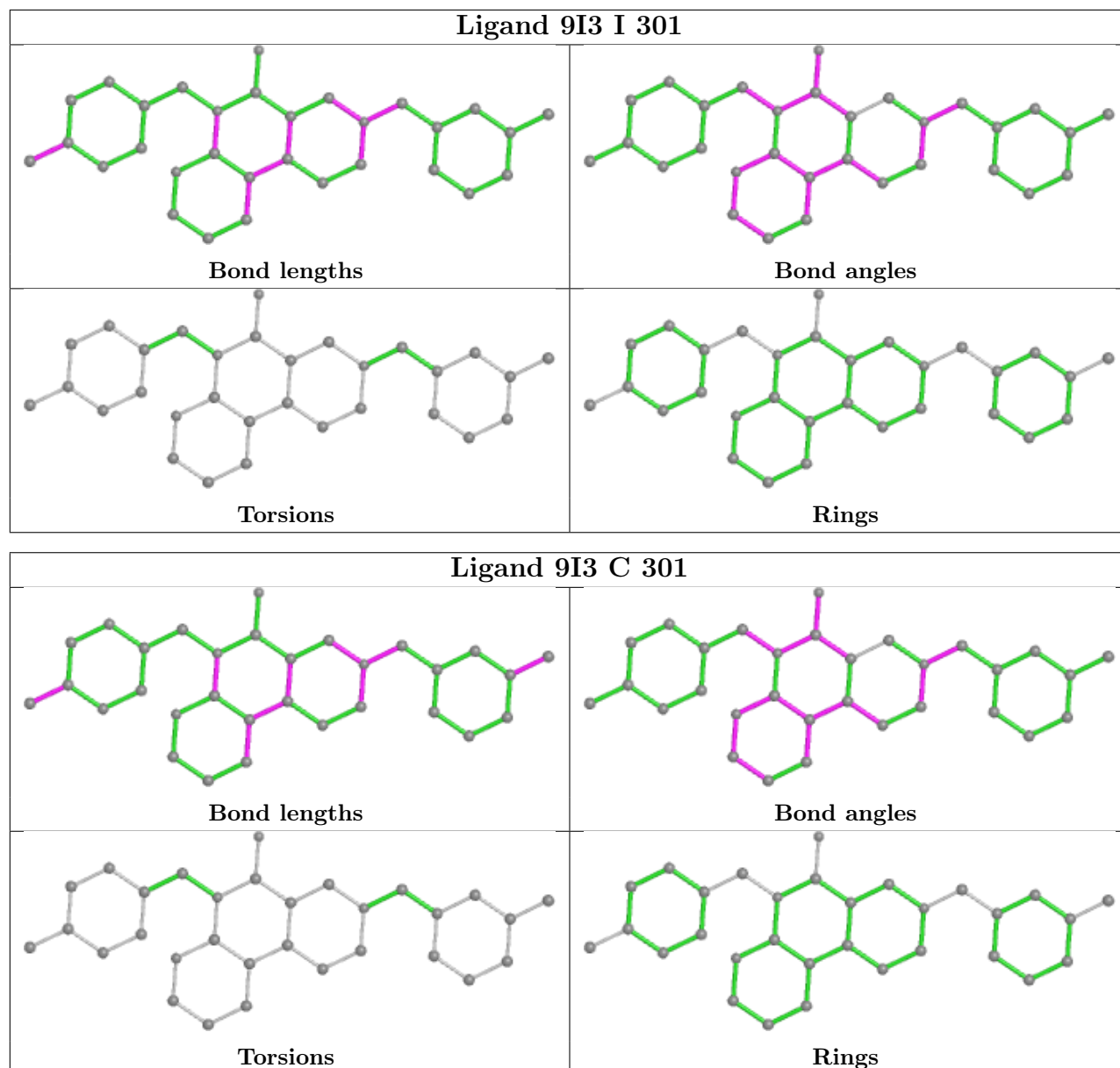

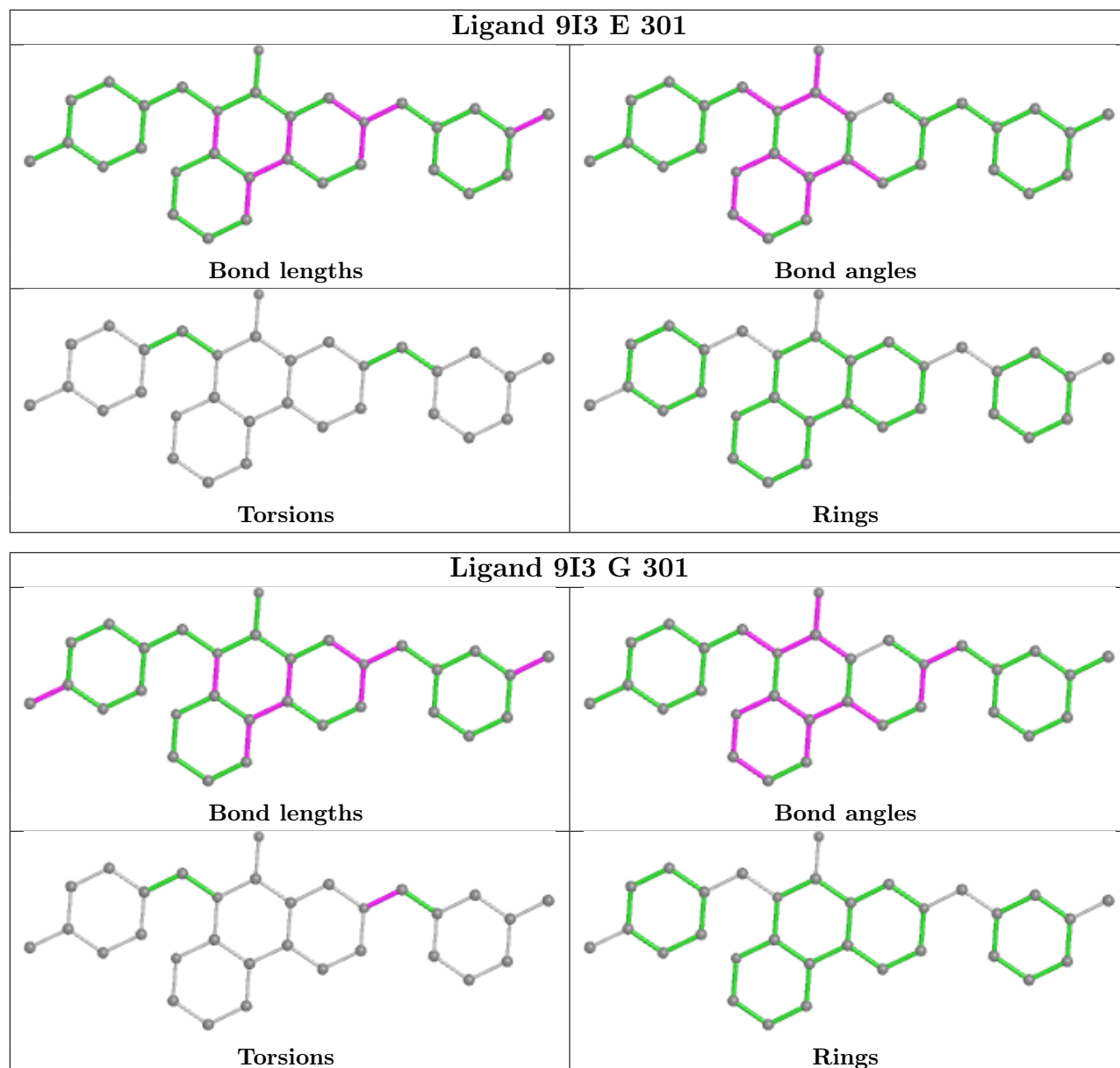

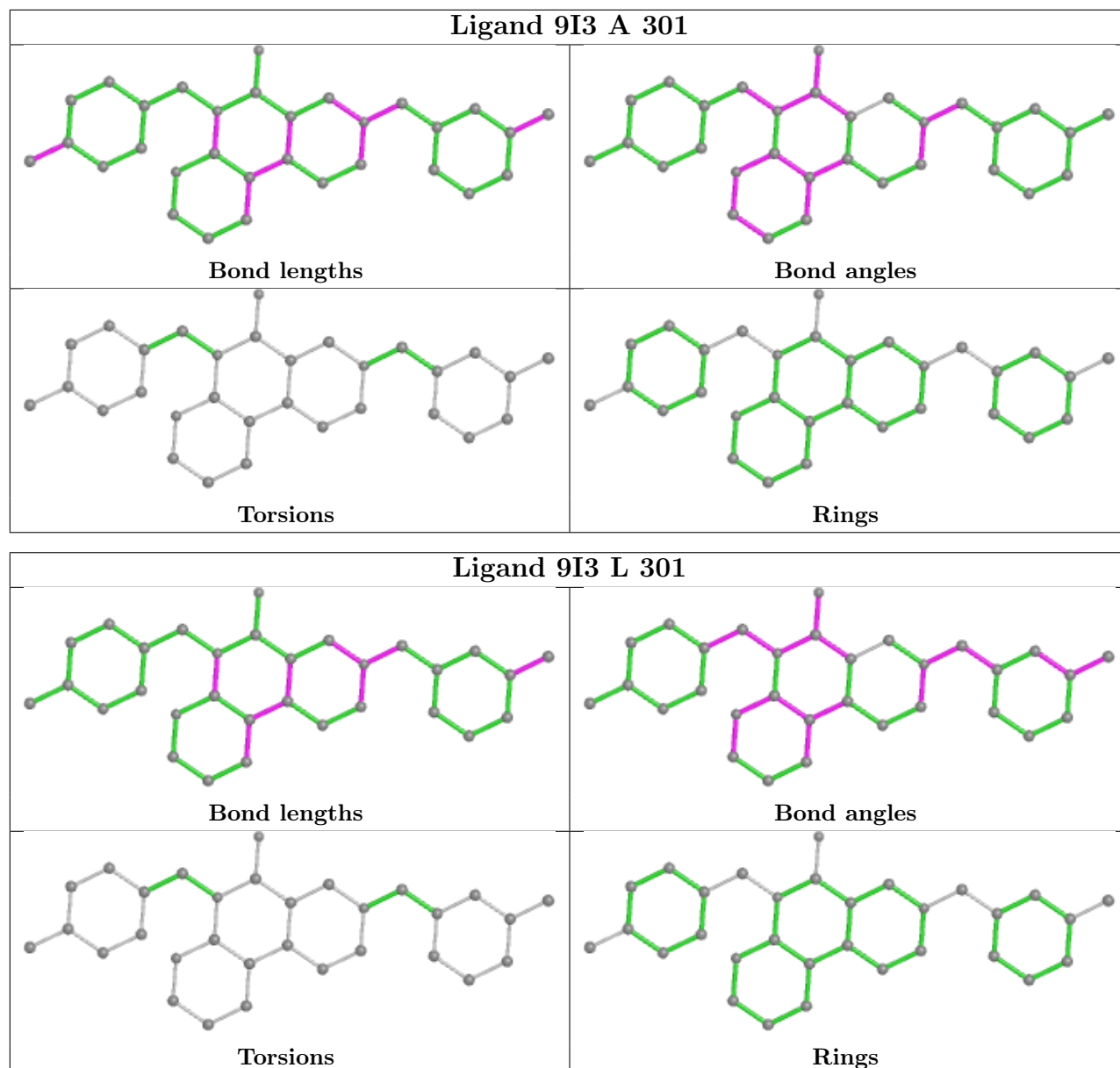

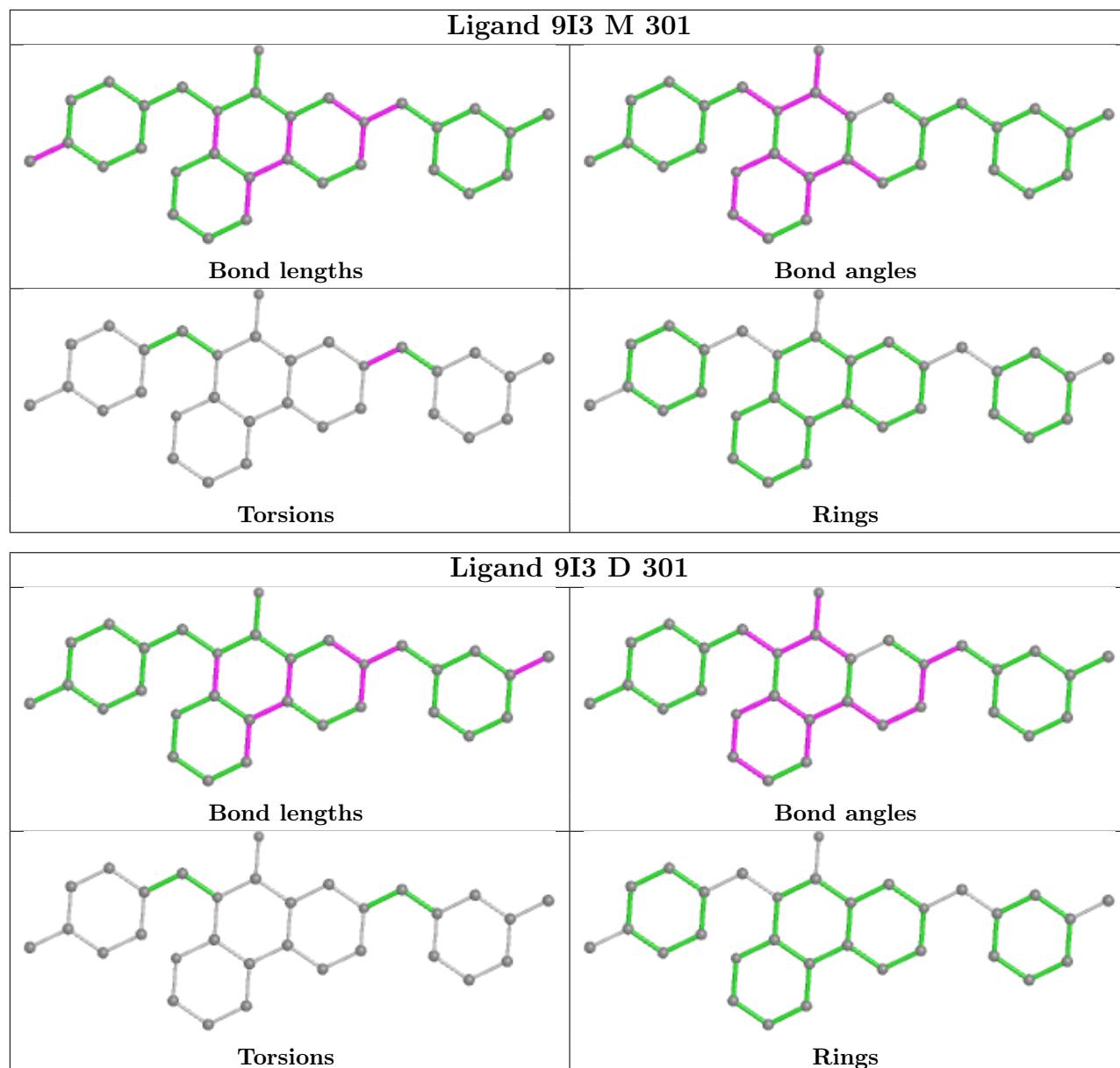

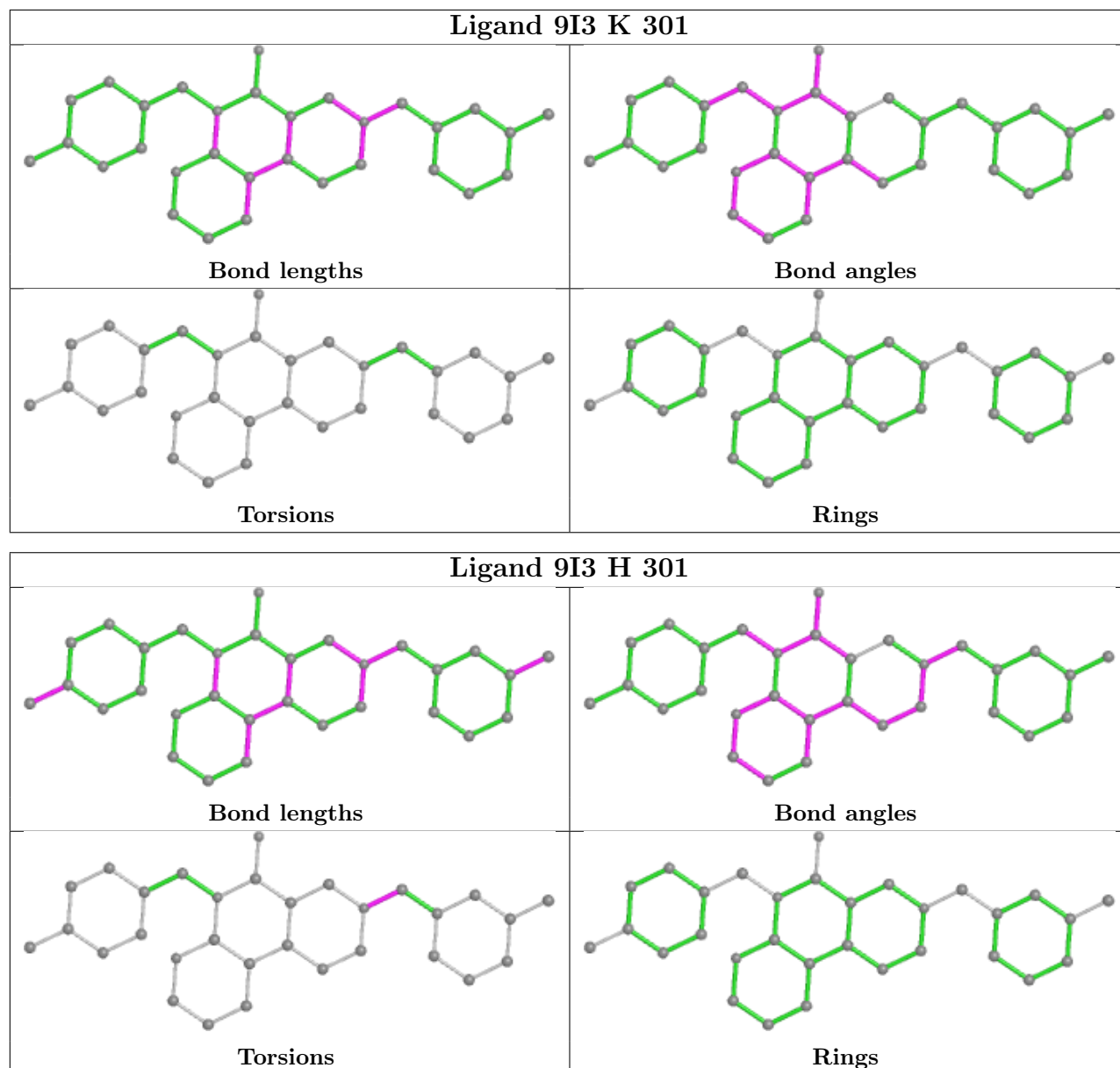

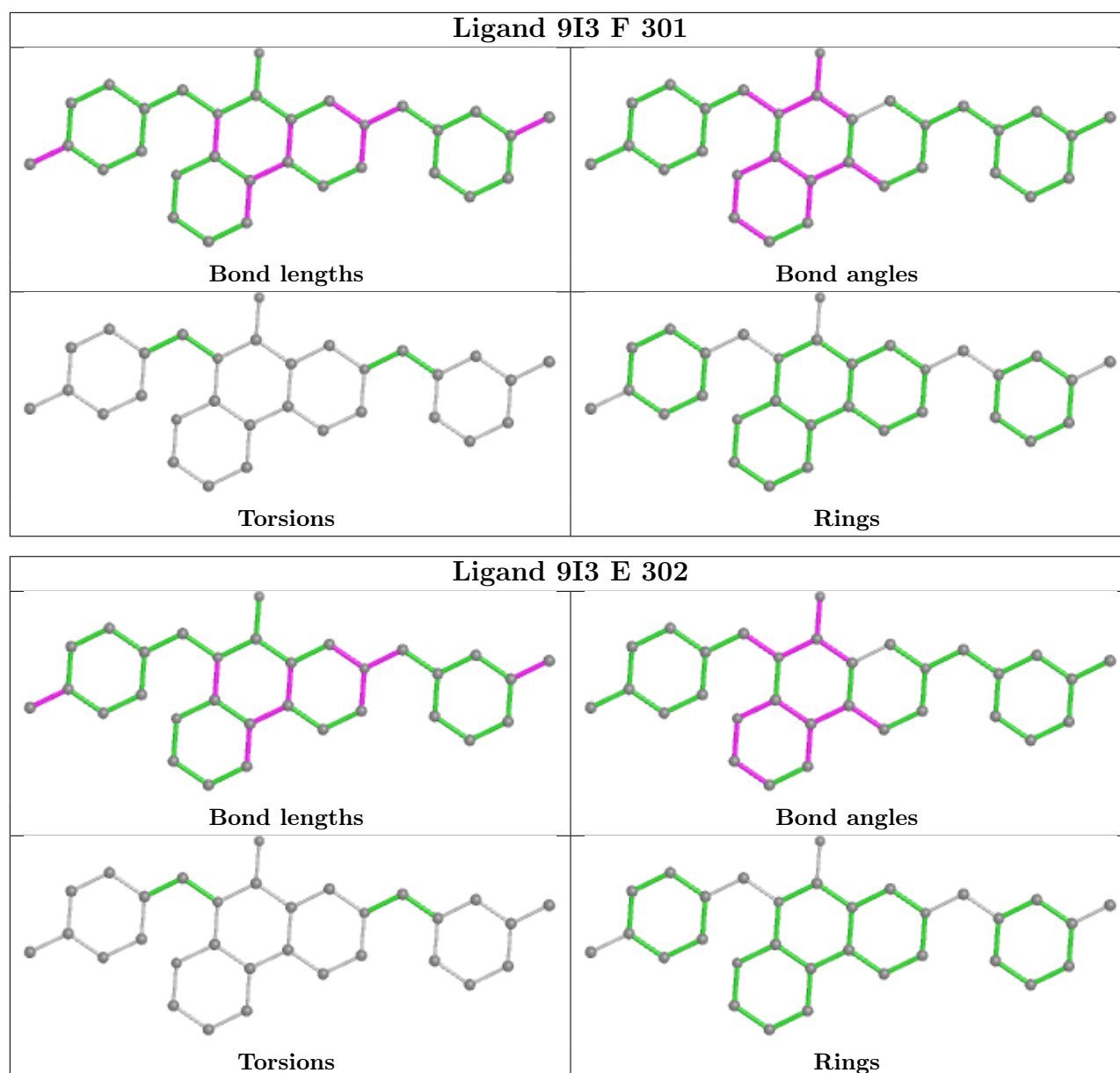

5.7 Other polymers [i](#)

There are no such residues in this entry.

5.8 Polymer linkage issues [i](#)

There are no chain breaks in this entry.

6 Fit of model and data [i](#)

6.1 Protein, DNA and RNA chains [i](#)

In the following table, the column labelled '#RSRZ > 2' contains the number (and percentage) of RSRZ outliers, followed by percent RSRZ outliers for the chain as percentile scores relative to all X-ray entries and entries of similar resolution. The OWAB column contains the minimum, median, 95th percentile and maximum values of the occupancy-weighted average B-factor per residue. The column labelled 'Q < 0.9' lists the number of (and percentage) of residues with an average occupancy less than 0.9.

Mol	Chain	Analysed	<RSRZ>	#RSRZ>2	OWAB(Å ²)	Q<0.9
1	A	175/223 (78%)	0.72	10 (5%) 30 24	23, 51, 81, 107	1 (0%)
1	B	176/223 (78%)	0.57	12 (6%) 25 19	32, 53, 90, 130	0
1	C	175/223 (78%)	0.67	15 (8%) 18 13	26, 52, 88, 122	2 (1%)
1	D	176/223 (78%)	0.95	19 (10%) 12 9	28, 55, 83, 102	1 (0%)
1	E	174/223 (78%)	0.75	18 (10%) 13 10	26, 55, 85, 113	1 (0%)
1	F	177/223 (79%)	1.18	25 (14%) 7 6	30, 56, 87, 129	1 (0%)
1	G	176/223 (78%)	0.82	15 (8%) 18 14	35, 58, 90, 116	0
1	H	175/223 (78%)	1.42	34 (19%) 4 4	37, 61, 92, 119	0
1	I	169/223 (75%)	1.55	48 (28%) 1 2	41, 63, 86, 104	0
1	J	168/223 (75%)	1.01	24 (14%) 7 6	40, 63, 92, 126	0
1	K	172/223 (77%)	1.29	28 (16%) 5 5	44, 69, 95, 142	0
1	L	172/223 (77%)	1.25	23 (13%) 8 7	43, 68, 95, 121	0
1	M	170/223 (76%)	1.68	59 (34%) 1 1	38, 71, 101, 137	1 (0%)
1	N	171/223 (76%)	1.62	49 (28%) 1 2	44, 72, 104, 160	0
All	All	2426/3122 (77%)	1.10	379 (15%) 6 5	23, 60, 92, 160	7 (0%)

The worst 5 of 379 RSRZ outliers are listed below:

Mol	Chain	Res	Type	RSRZ
1	F	149	GLY	6.8
1	K	149	GLY	6.7
1	H	151	ALA	6.7
1	B	173	SER	6.4
1	I	63	VAL	5.4

6.2 Non-standard residues in protein, DNA, RNA chains [i](#)

There are no non-standard protein/DNA/RNA residues in this entry.

6.3 Carbohydrates [i](#)

There are no monosaccharides in this entry.

6.4 Ligands [i](#)

In the following table, the Atoms column lists the number of modelled atoms in the group and the number defined in the chemical component dictionary. The B-factors column lists the minimum, median, 95th percentile and maximum values of B factors of atoms in the group. The column labelled 'Q< 0.9' lists the number of atoms with occupancy less than 0.9.

Mol	Type	Chain	Res	Atoms	RSCC	RSR	B-factors(\AA^2)	Q<0.9
2	9I3	M	301	31/31	0.71	0.31	99,101,102,107	0
2	9I3	H	301	31/31	0.80	0.17	67,69,70,70	0
2	9I3	L	301	31/31	0.81	0.15	61,62,65,68	0
2	9I3	E	302	31/31	0.82	0.15	57,59,60,62	0
2	9I3	E	301	31/31	0.82	0.14	57,59,60,63	0
2	9I3	N	301	31/31	0.82	0.18	69,72,75,78	0
2	9I3	D	301	31/31	0.84	0.16	62,64,65,66	0
2	9I3	K	301	31/31	0.85	0.17	88,91,92,95	0
2	9I3	A	301	31/31	0.85	0.14	57,59,63,64	0
2	9I3	C	301	31/31	0.85	0.15	61,63,65,65	0
2	9I3	I	301	31/31	0.85	0.16	66,68,71,72	0
2	9I3	B	301	31/31	0.86	0.15	63,65,67,68	0
2	9I3	G	301	31/31	0.86	0.15	64,66,69,71	0
2	9I3	F	301	31/31	0.88	0.15	58,60,62,66	0

The following is a graphical depiction of the model fit to experimental electron density of all instances of the Ligand of Interest. In addition, ligands with molecular weight > 250 and outliers as shown on the geometry validation Tables will also be included. Each fit is shown from different orientation to approximate a three-dimensional view.

Electron density around 9I3 M 301:

$2mF_o-DF_c$ (at 0.7 rmsd) in gray
 mF_o-DF_c (at 3 rmsd) in purple (negative)
and green (positive)

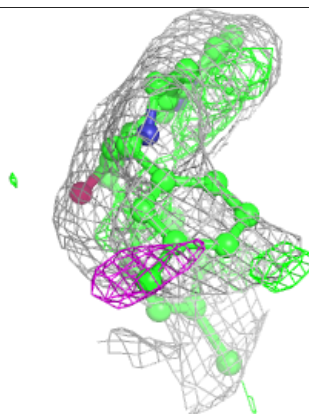
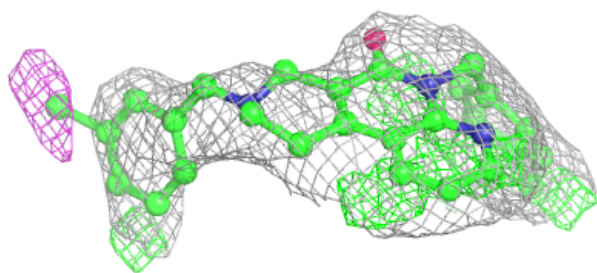
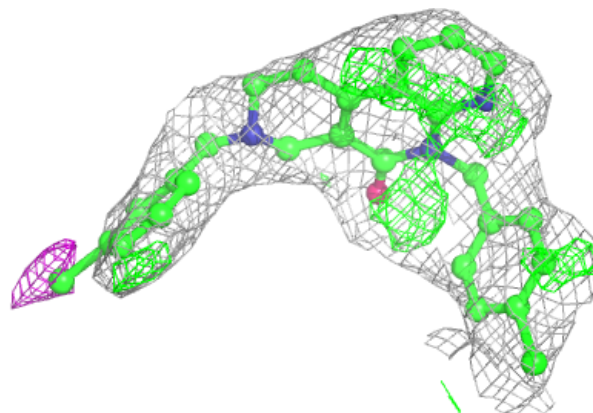

Electron density around 9I3 H 301:

$2mF_o-DF_c$ (at 0.7 rmsd) in gray
 mF_o-DF_c (at 3 rmsd) in purple (negative)
and green (positive)

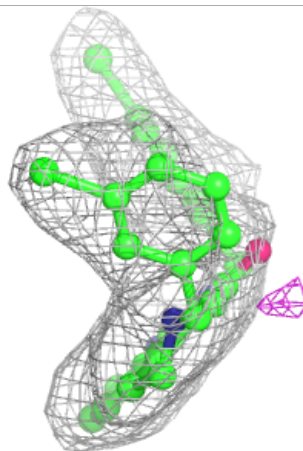
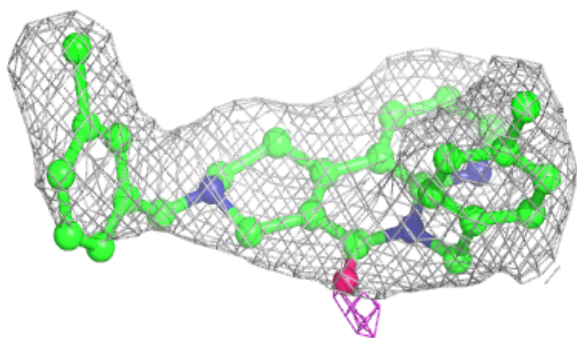
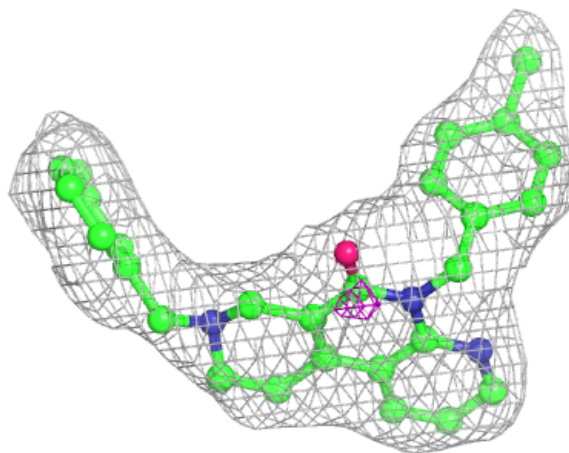

Electron density around 9I3 L 301:

$2mF_o-DF_c$ (at 0.7 rmsd) in gray
 mF_o-DF_c (at 3 rmsd) in purple (negative)
and green (positive)

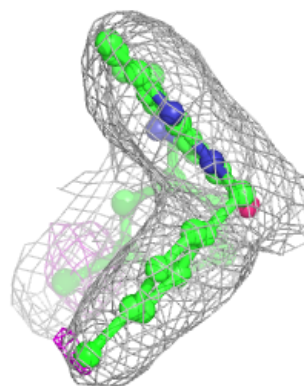
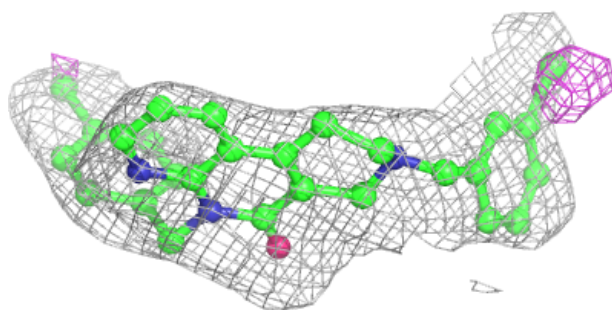
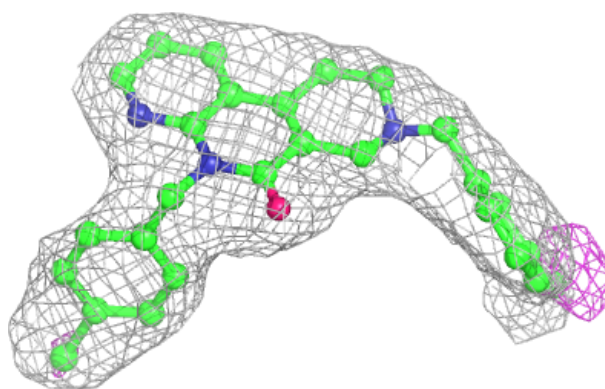
**Electron density around 9I3 E 302:**

$2mF_o-DF_c$ (at 0.7 rmsd) in gray
 mF_o-DF_c (at 3 rmsd) in purple (negative)
and green (positive)

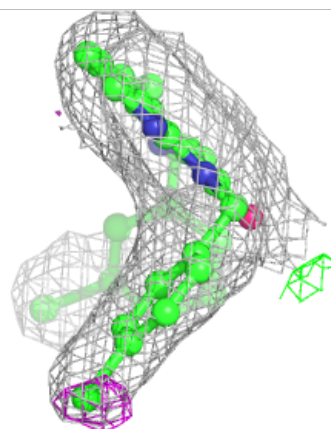
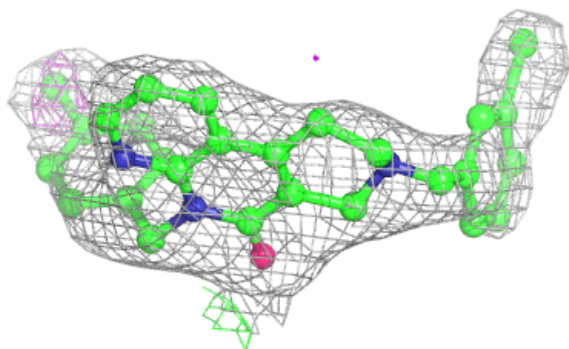
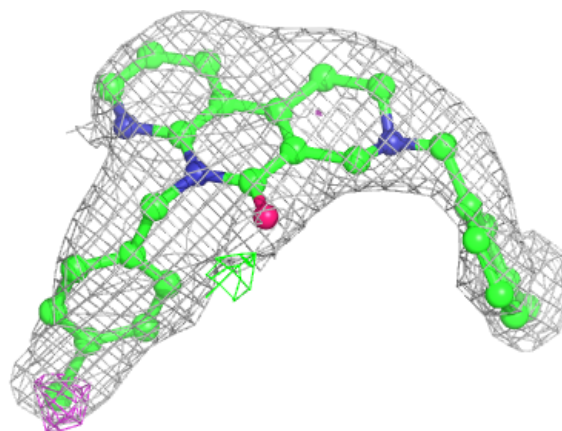

Electron density around 9I3 E 301:

$2mF_o-DF_c$ (at 0.7 rmsd) in gray
 mF_o-DF_c (at 3 rmsd) in purple (negative)
and green (positive)

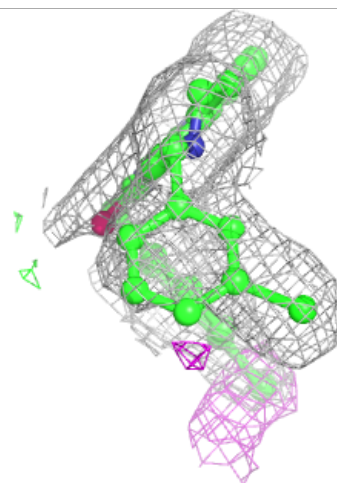
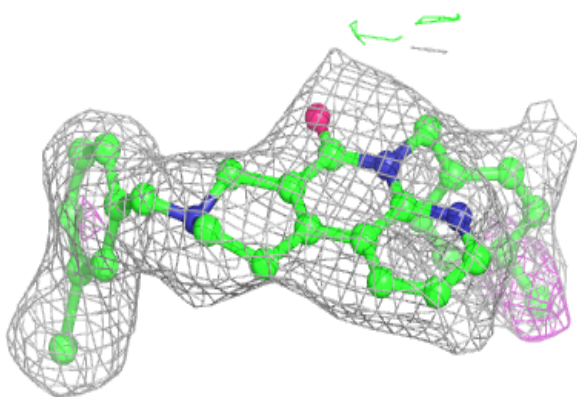
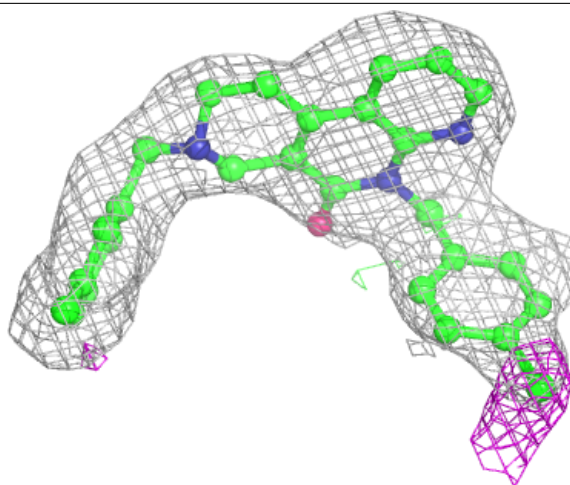

Electron density around 9I3 N 301:

$2mF_o-DF_c$ (at 0.7 rmsd) in gray
 mF_o-DF_c (at 3 rmsd) in purple (negative)
and green (positive)

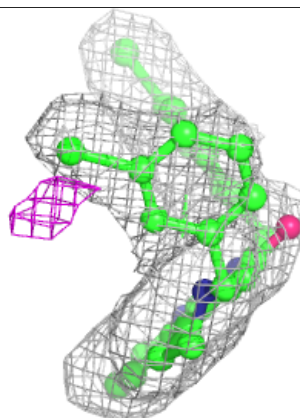
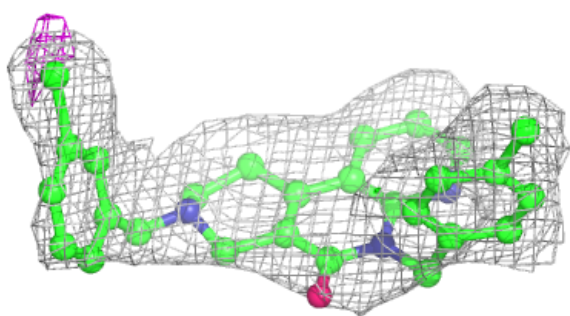
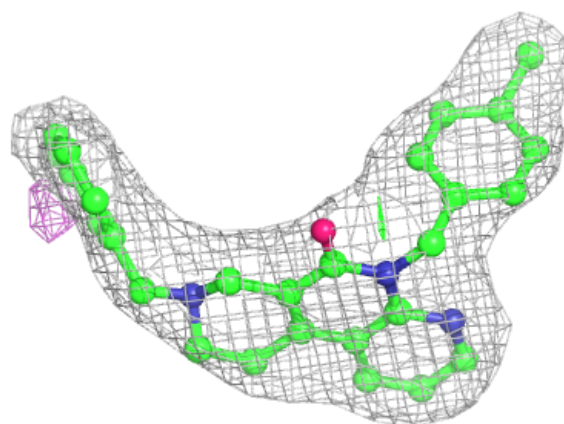

Electron density around 9I3 D 301:

$2mF_o-DF_c$ (at 0.7 rmsd) in gray
 mF_o-DF_c (at 3 rmsd) in purple (negative)
and green (positive)

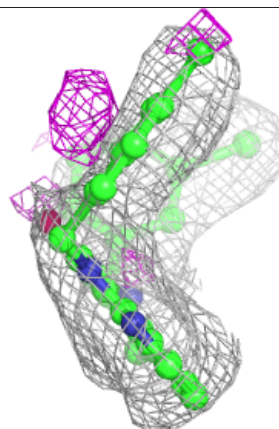
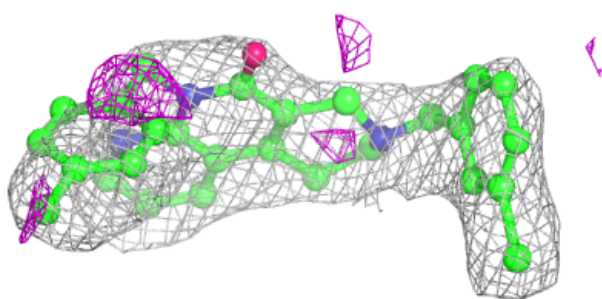
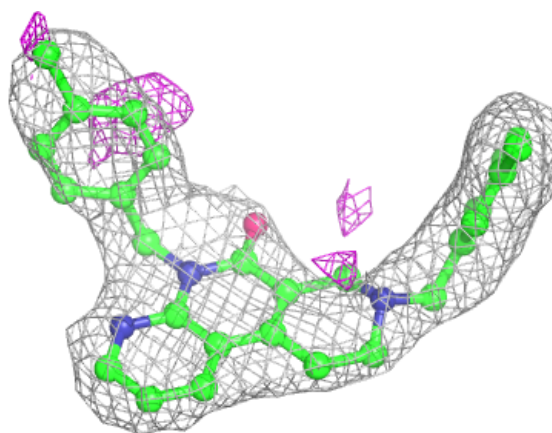
**Electron density around 9I3 K 301:**

$2mF_o-DF_c$ (at 0.7 rmsd) in gray
 mF_o-DF_c (at 3 rmsd) in purple (negative)
and green (positive)

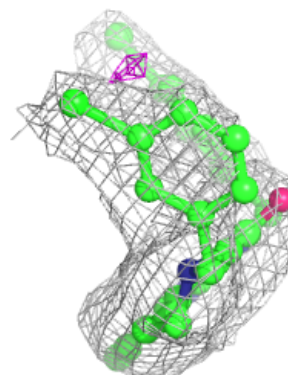
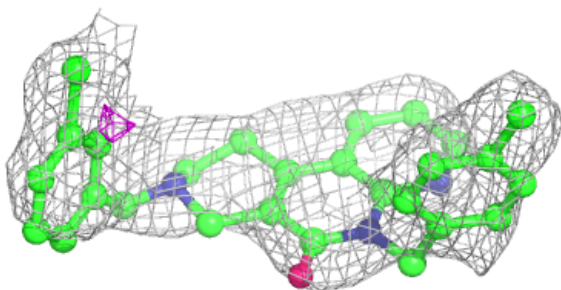
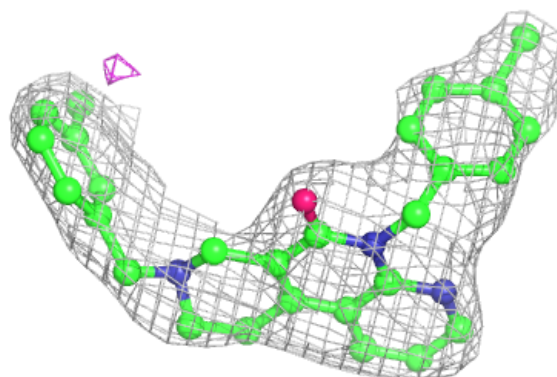

Electron density around 9I3 A 301:

$2mF_o-DF_c$ (at 0.7 rmsd) in gray
 mF_o-DF_c (at 3 rmsd) in purple (negative)
and green (positive)

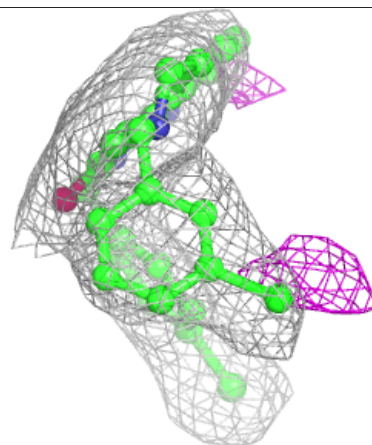
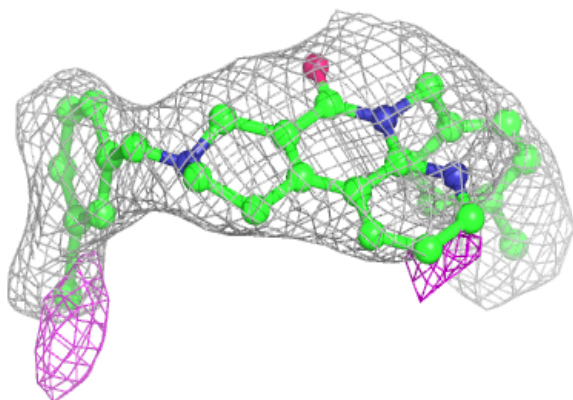
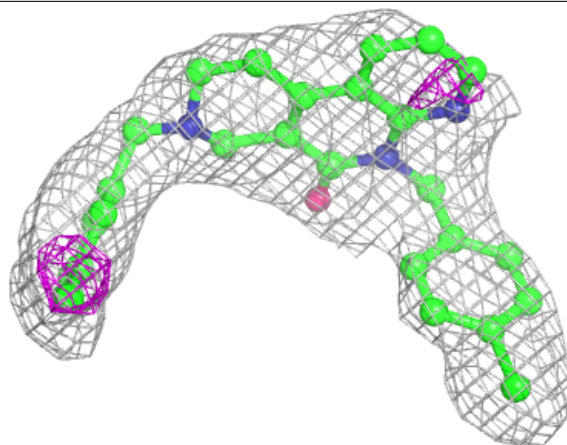

Electron density around 9I3 C 301:

$2mF_o-DF_c$ (at 0.7 rmsd) in gray
 mF_o-DF_c (at 3 rmsd) in purple (negative)
and green (positive)

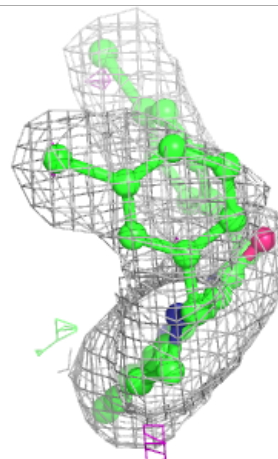
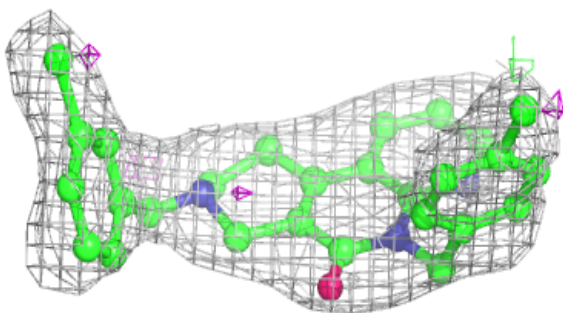
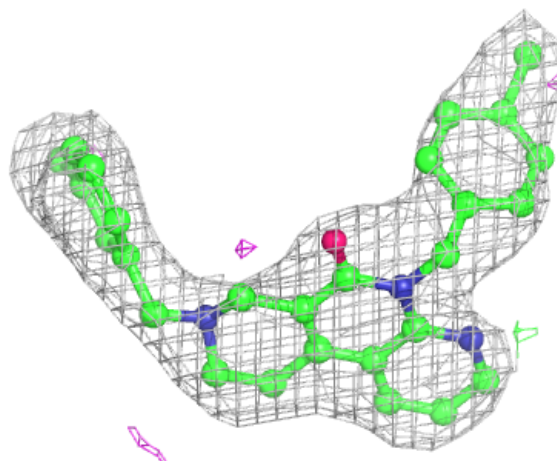

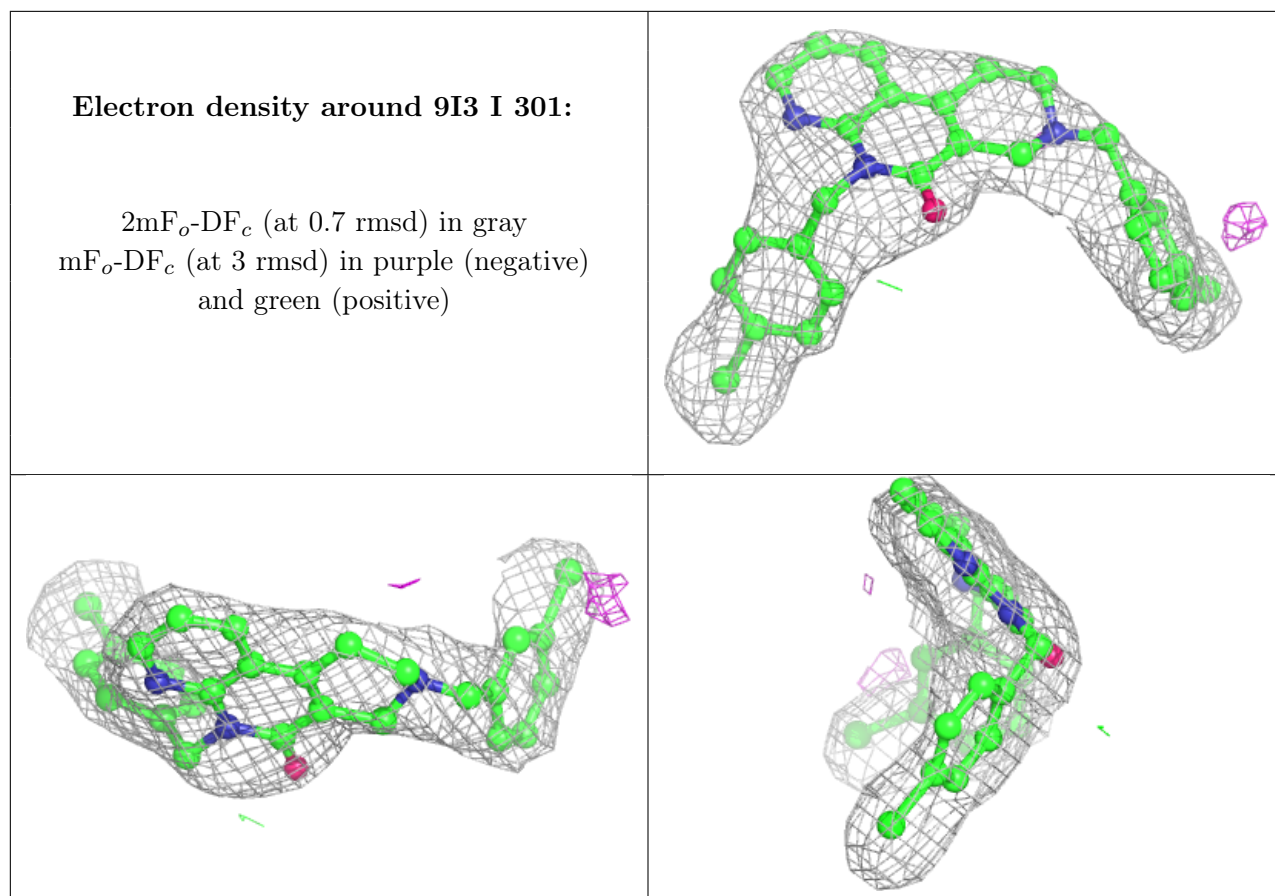

Electron density around 9I3 B 301:

$2mF_o-DF_c$ (at 0.7 rmsd) in gray
 mF_o-DF_c (at 3 rmsd) in purple (negative)
and green (positive)

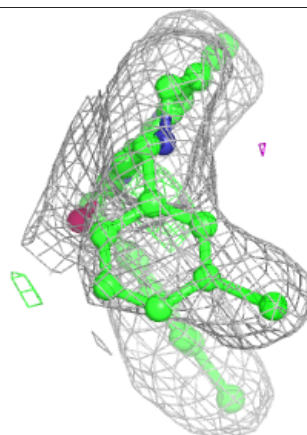
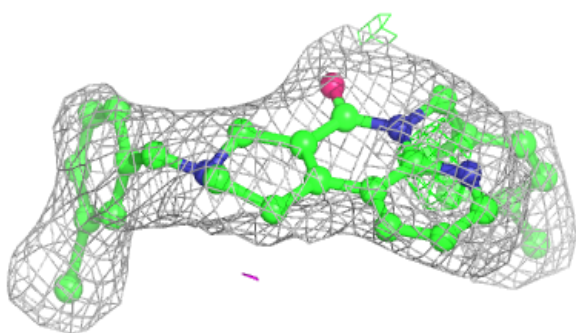
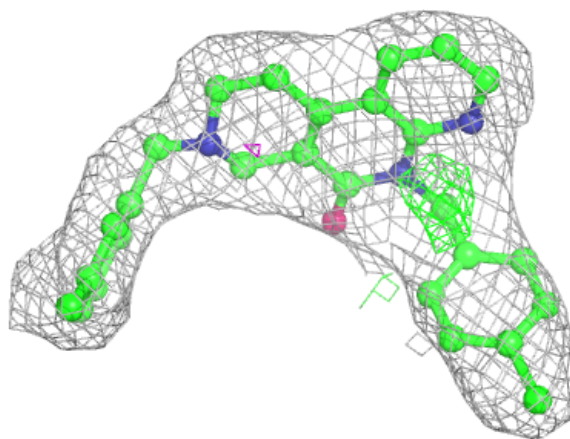

Electron density around 9I3 G 301:

$2mF_o-DF_c$ (at 0.7 rmsd) in gray
 mF_o-DF_c (at 3 rmsd) in purple (negative)
and green (positive)

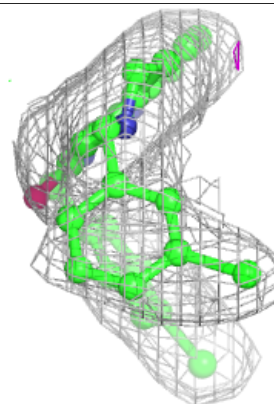
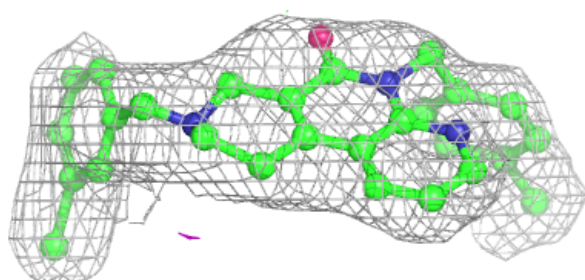
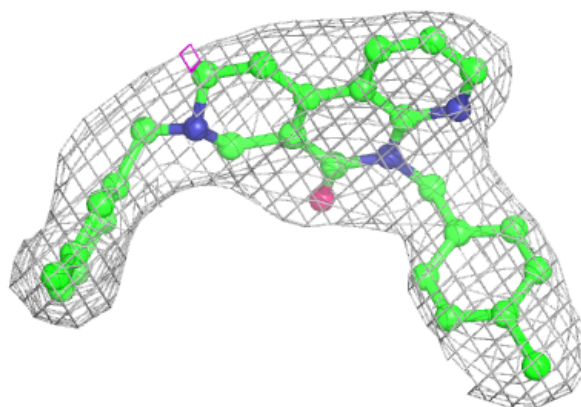
**Electron density around 9I3 F 301:**

$2mF_o-DF_c$ (at 0.7 rmsd) in gray
 mF_o-DF_c (at 3 rmsd) in purple (negative)
and green (positive)

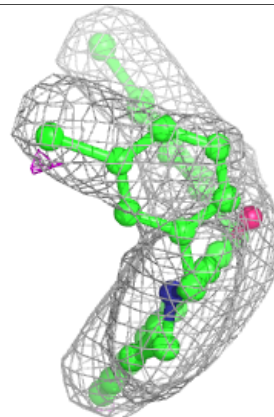
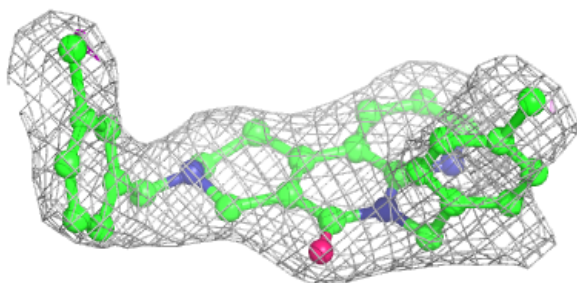
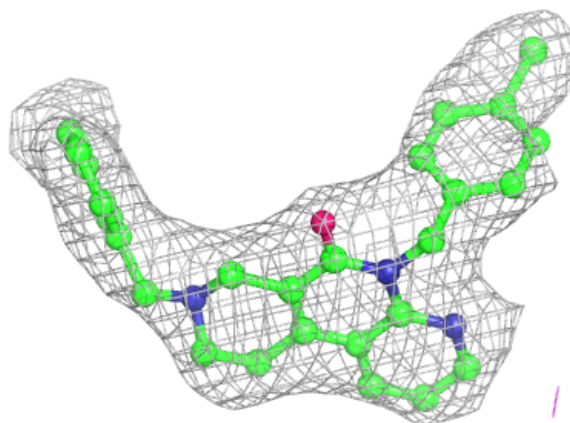

6.5 Other polymers [i](#)

There are no such residues in this entry.